

# SECTION 6 MATERIAL UNLOADING

## Rail Car Unloaders

### INLET HATCH FILTER

In most cases you will need to open one hatch when unloading a railcar to avoid implosion or collapse when unloading. The Smoot Inlet Hatch Filter was designed to restrict foreign objects or airborne particles from entering the railcar while the hatch is open.

### PRODUCT FEATURES

- Aluminum construction
- Rated capacity: 1,100 CFM

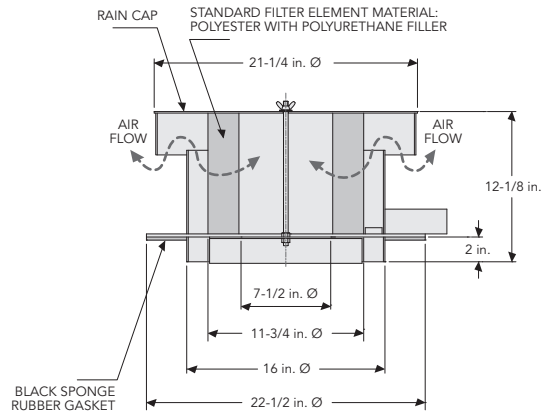
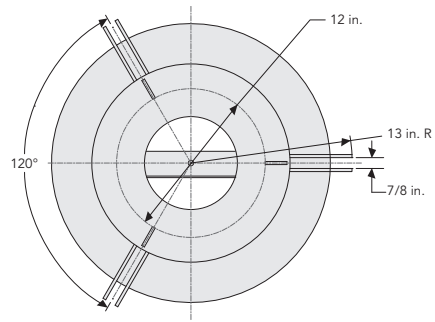

### DRY-FLO RAIL CAR DISCHARGE ADAPTER

This adapter was designed for the General America Transportation Corporation's Dry-Flo railcar, but it will work on other cars as well. If your railcar is of a different manufacturer, consult that manufacturer's instruction manual for the proper unloading procedure.

### PRODUCT FEATURES

- Aluminum construction

MODEL NUMBER	D (INCHES)	L (INCHES)	SHIPPING WEIGHT (POUNDS)
34A-1-2	2	15-7/8	15
34A-1-3	3	14-1/16	15
34A-1-4	4	12-5/8	16
34A-1-5	5	12	18
34A-1-6	6	10-3/4	20

**Note:** Dimension **L** may vary slightly depending on the type of Quick Coupler Adapter used in manufacture.

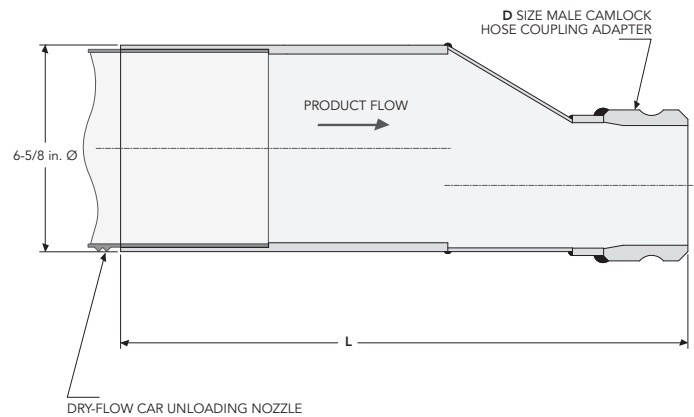

# SECTION 6 MATERIAL UNLOADING

## Rail Car Unloaders

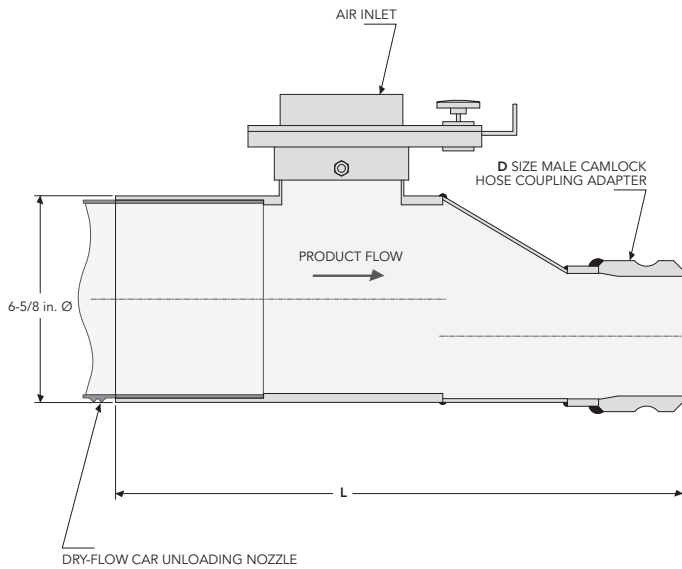

### CENTER FLOW RAIL CAR DISCHARGE ADAPTER

This adapter was designed for the ACF Center Flow Pneumatic outlet, but it will work on other cars as well. If your railcar is of a different manufacturer, consult that manufacturer's instruction manual for the proper unloading procedure.

#### PRODUCT FEATURES

- Aluminum construction

MODEL NUMBER	D (INCHES)	L (INCHES)	SHIPPING WEIGHT (POUNDS)
34A-2-2	2	23-1/8	16
34A-2-3	3	21-5/16	16
34A-2-4	4	19-7/8	17
34A-2-5	5	19-15/16	19
34A-2-6	6	19	21

**Note:** Dimension L may vary slightly depending on the type of Quick Coupler Adapter used in manufacture.

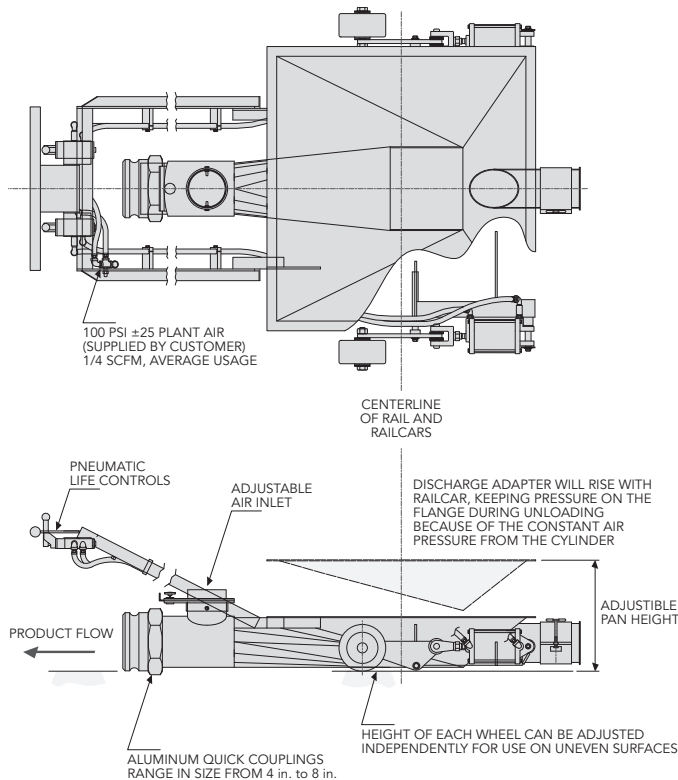

### AIRLIFT RAIL CAR DISCHARGE ADAPTER

When manual adapters take too much time and manpower to connect for railcar unloading, the Smoot Airlift Adapter can be the solution to overcoming these problems. Airlift Adapters provide you versatility for movement not found in Bootlift style fixed pit unloaders which also require tedious railcar spotting prior to use.

#### PRODUCT FEATURES

- Carbon Steel standard construction
- Stainless steel product contact areas available
- NEMA 4 electrical component classification
- NEMA 4X, 7 & 9 classified components available upon request
- Many standard sizes for all applications available, contact your Smoot Representative for details

# SECTION 6 MATERIAL UNLOADING

## Rail Car Unloaders

### 24X30 CENTER FLOW RAIL CAR DISCHARGE ADAPTER

These discharge adapters fit 24x30 center flow enterprise gate equipped rail cars.

#### PRODUCT FEATURES

- Carbon steel construction (standard)
- Recommended two adapters per installation
- Four vise grip C-clamps supplied per adapter

MODEL NUMBER	Dimensions (inches)					
	D LINE SIZE	E VENT SIZE	F	K	L	M
B1	4	3	4	6-1/2	34	56
B2	5	4	4	6-1/2	34	56
B3	6	5	5	6-1/2	36	56
B4	8	6	6	7-1/2	42	59-1/2

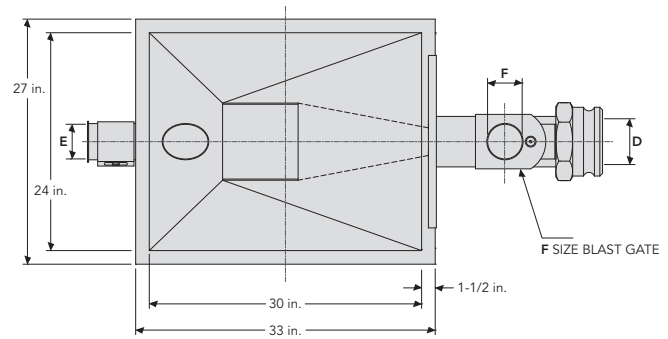

THE RAILCAR DISCHARGE ADAPTER PAN IS USED WITH THIS CAP ATTACHED IN MOST CASES. OPENING THE CAP PERMITS AIR TO ENTER HERE RATHER THAN THROUGH THE CAR, WHICH IS DESIRABLE TO CLEAN OUT THE PAN WHEN THE CAR IS EMPTY. ANOTHER ALTERNATIVE IS TO REMOVE THE CAP AND INSERT A SHORT TUBE SO AS TO BE ABLE TO CONTROL THE AMOUNT OF AIR PICKING UP THE PRODUCT.

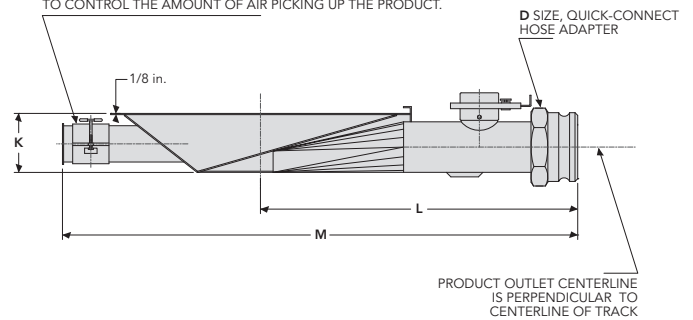

### 13X24 RAIL CAR DISCHARGE ADAPTER

- Carbon steel construction (standard)
- Recommended two adapters per installation.
- Four vise grip C-clamps supplied per adapter.

MODEL NUMBER	A LINE SIZE (INCHES)	SHIPPING WEIGHT (POUNDS)
34E-1A-4	4	10
34E-1A-5	5	10
34E-1A-6	6	12
34E-1A-8	8	12

