

TYPE 1 AIR OUTLET TYPE 2 AIR OUTLET (RAIN SHIELD) TYPE 3 AIR OUTLET (LOW PROFILE OUTLET) (INFINITE OUTLET ORIENTATION) TYPE 4 AIR OUTLET

PIPE FLANGE					
MODEL DASH No. "C"	ASA PIPE FLG SIZE	NOMINAL DIMENSIONS			
		K DIA	O DIA	V	AA
C1	4	4	9	8	7 1/2
C2	5	5	10	8	8 1/2
C3	6	6	11	8	9 1/2
C4	8	8	13 1/2	8	11 3/4
C5	10	10	16	12	14 1/4
C6	12	12	19	12	17
C7	14	14	21	12	18 3/4
C8	16	16	23 1/2	16	21 1/4

FEEDER FLANGE							
MODEL DASH No. "C"	FEEDER FLANGE SIZE	NOMINAL DIMENSIONS					
		K DIA	O SQ	V	X	Y	Z
C9	FT-7	6	11	8	4 3/4	3/4	2
C10	FT-9	8	12	8	5 1/4	3/4	2
C11	FT-11	9	13	8	5 3/4	3/4	2
C12	FT-12	10	15	8	6 1/2	1	2
C13	FT-14	12	17	12	5 1/4	5/8	3
C14	FT-16	13	18	12	5 1/2	3/4	3
C15	FT-18	15	20	12	6	1	3
C16	FT-22	16	22	16	5	1	4
C17	FT-30	23	31	16	7	1 1/2	4

MODEL DASH No. "B"	SIZE #	DIMENSIONS															
		A OD	B	C OD	D OD	E	F OD	H	J	L	M	N	P	R	S	T	W
B1P	1	1 1/2	25 1/2	2	5	5 3/16	6 5/8	12	3 1/2	14 5/8	12 5/8	1	7 3/4	2 3/4	6 1/2	29 7/8	6 7/16
B2T	2	2	28	2 3/8	5 9/16	5 1/4	8	12	3 1/2	16	14	1 5/16	8 13/16	3	6 7/8	32 9/16	6 11/16
B2P	3	2 3/8	30	3	6	6 1/4	10	12	3 1/2	18	16	1 9/16	9 1/2	3 1/4	7 3/8	34 7/8	7
B3T	4	3	33	3 1/2	6 5/8	6 3/8	11	12	3 1/2	19	17	1 15/16	10 7/8	3 1/2	8	38 1/8	7 5/16
B3P	5	3 1/2	38	4	8	8 5/16	12 3/4	15	3 1/2	20 3/4	18 3/4	2 3/8	11 3/4	3 3/4	9 3/8	43 3/8	8
B4T	6	4	44	5	8 5/8	9 7/16	14	20	3 1/2	22	20	2 9/16	12 1/2	4	9	49 7/8	9 5/16
B4P	7	4 1/2	45	5 9/16	12	9 9/16	16	20	4 1/2	24	22	2 7/8	14	4 1/2	10 1/8	51 3/16	11
B5T	8	5	51 1/2	6	14	11 1/2	18	24	4 1/2	26	24	2 13/16	15 1/8	5	11 1/8	58 3/16	12
B5P	9	5 9/16	58 1/2	6 5/8	14	11 5/8	20	28	4 1/2	28	26	3 1/2	16 1/4	5	11 1/8	65 3/16	12
B6T	10	6	65	8	16	13 11/16	21 1/2	32	4 1/2	29 1/2	27 1/2	3 3/4	17 1/4	5 3/4	12 1/2	72 3/8	14
B6P	11	6 5/8	70	8	16	13 11/16	22 1/2	34	4 1/2	30 1/2	28 1/2	4 1/4	18 1/2	5 3/4	12 1/2	77 3/8	14
B8T	13	8	91	10	20	16 7/8	28	47	5 1/2	36	34	5	21 1/2	6 3/4	14 1/2	99 3/8	16
B8P	14	8 5/8	100	10 3/4	21 1/2	17	30	52	6 1/2	38	36	5 3/8	24 1/8	7 1/8	15 1/4	108 3/4	16 3/4
B10T	16	10	115	12	25 1/2	19	35 1/2	60	6 1/2	43 1/2	41 1/2	6 3/16	26 3/4	8 1/8	17 1/4	124 3/4	20 3/4
B10P	17	10 3/4	125	12 3/4	25 1/2	19 3/16	38	65	7 1/2	46	44	6 11/16	28 1/2	8 1/8	17 1/4	134 3/4	20 3/4
B12T	18	12	140	14	28	23 1/2	41 1/2	74	7 1/2	49 1/2	47 1/2	7 7/16	32	8 3/4	18 1/2	150 3/8	22
B12P	19	12 3/4	145	16	32	23 1/2	43	75	8 1/2	51	49	7 15/16	33 1/2	9 3/4	20 5/8	156 3/8	24

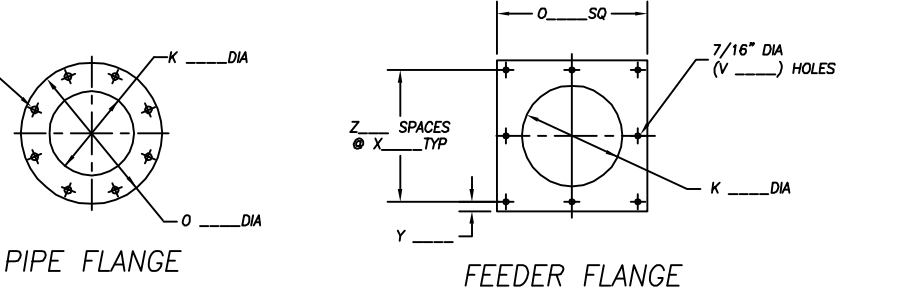
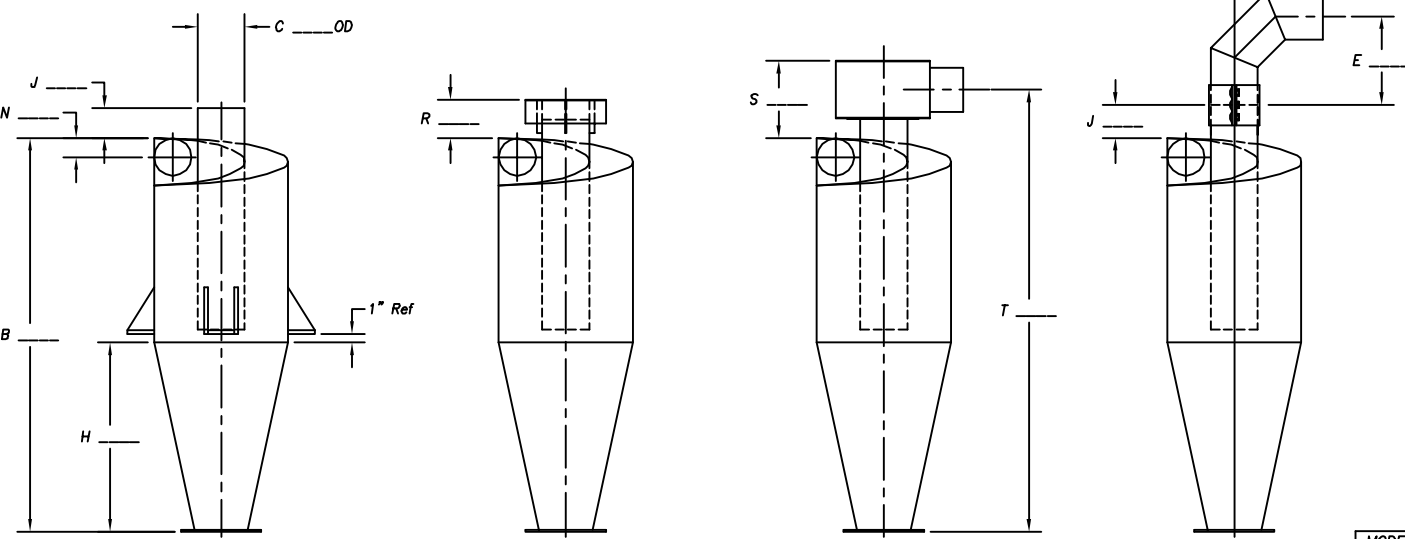

MODEL DASH No. "D"	INLET ORIENTATION
D1	LEFT HAND
D2	RIGHT HAND
L.H. ORIENTATION SHOWN	

MODEL DASH No. "E"	AIR OUTLET TYPE
E1	TYPE 1
E2	TYPE 2
E3	TYPE 3
E4	TYPE 4

MODEL DASH No. "F"	MATERIAL OF CONSTRUCTION
F1	CARBON STEEL
F2	304 SS
F3	ALUMINUM

MODEL DASH No. "G"	MATERIAL GRADE	MINIMUM CYCLONE SIZE THAT CAN BE CONSTRUCTED OF SPECIFIED MATERIAL
G1	14 GA.	SIZE #1
G2	12 GA.	SIZE #1
G3	10 GA.	SIZE #6
G4	1/4"	SIZE #8

CUSTOMER: _____
 CUST. P.O. NO. _____
 SMOOT JOB NO. _____
 ITEM NO. _____
 QTY: _____
 DRAWING ISSUE: _____

THIS DRAWING IS THE EXCLUSIVE PROPERTY OF SMOOT. IT'S ACCEPTANCE CONSTITUTES AN AGREEMENT THAT IT SHALL BE TREATED AS A STRICTLY CONFIDENTIAL DOCUMENT AND IS TO BE RETURNED UPON REQUEST AND IS NOT TO BE COMMUNICATED, DISCLOSED, LOANED OR COPIED EXCEPT AS EXPRESSLY AUTHORIZED IN WRITING BY SMOOT. EDITING THIS DOCUMENT INVALIDATES THE DRAWING AS A WHOLE, DISCREPANCIES, CORRECTIONS, OR REVISIONS ARE TO BE COMMUNICATED TO SMOOT COMPANY TO BE IMPLEMENTED.



2205 Jothi Avenue
 Parsons, KS 67357
 Toll Free: 888.882.9567
 Fax: 620.421.5586

1250 Seminary St.
 Kansas City, KS 66103
 Toll Free: 800.748.7000
 Fax: 913.362.7863

MODEL DASH No. B,C	SIZE #	INLET LINE SIZE OD	PRODUCT DISCHARGE OUTLET OPTIONS																EST. EMPTY WEIGHT		
			ASA PIPE FLANGE								AIRLOCK FEEDER SIZE										
			C1	C2	C3	C4	C5	C6	C7	C8	C9	C10	C11	C12	C13	C14	C15	C16		C17	
B1T	1	1 1/2	4	5	6	8	10	12	14	16	FT7	FT9	FT11	FT12	FT14	FT16	FT18	FT22	FT30	125	
B2T	2	2	177
B2P	3	2 3/8	239
B3T	4	3	291
B3P	5	3 1/2	372
B4T	6	4	424
B4P	7	4 1/2	517
B5T	8	5	583
B5P	9	5 9/16	710
B6T	10	6	751
B6P	11	6 5/8	827
B8T	13	8	1148
B8P	14	8 5/8	1338
B10T	16	10	1605
B10P	17	10 3/4	1891
B12T	18	12	2084
B12P	19	12 3/4	2386

A115.1 - B - C - D - E - F - G - H - J

MODEL DASH No. "H"	SUPPORT LUGS OPTIONS
H1	SUPPORT LUGS
H2	NO SUPPORT LUGS

MODEL DASH No. "J"	ADDITIONAL OPTIONS
J1	DISCHARGE FLANGE SHIPPED LOOSE

CAT. FILE NO. 29-4-A
 REV NO. 1 10/23/91
 REV NO. 2 04/02/96
 REV NO. 3 11/23/98
 PAGE 1 OF 1

DATE 10/23/91
 DWN. BY RKN
 SCALE NONE

DWG. NO. 115-1-CA
 APPROVED _____

TUBE SIZES WILL BE 12 GAUGE
 PIPE SIZES WILL BE SCH 40
 UNLESS OTHERWISE SPECIFIED
 "P" REFERS TO PIPE,
 "T" REFERS TO TUBE.