

SECTION 1 ROTARY VALVES

Accessories – Shaft Air Purge



PRODUCT DESCRIPTION

Shaft Air Purge uses high pressure plant air to prevent the material from coming in contact with the shaft seals, which extends the life of the rotary valve. Considered to be beneficial in almost all applications.

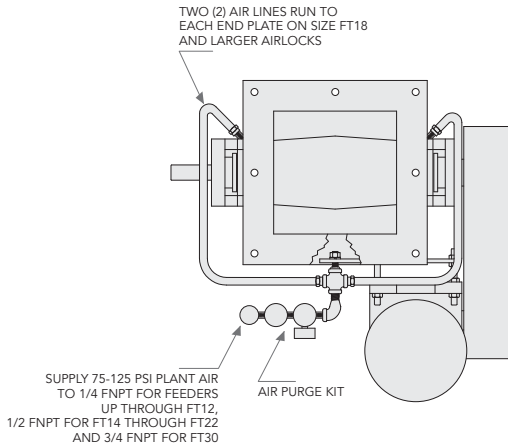

FT7 through FT16

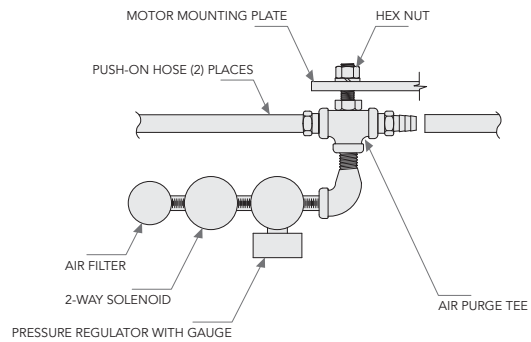

FT18 through FT30

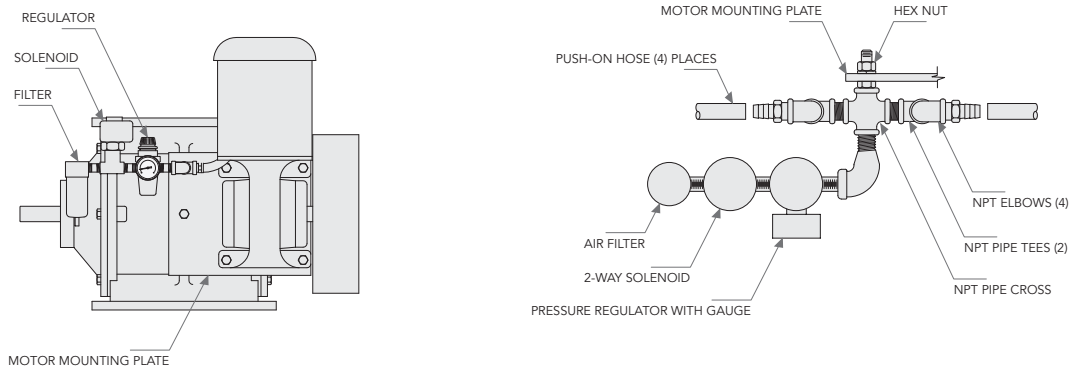

SAFETY NOTICE

The inlet and outlet of the rotary valve must have proper attachments to prevent anyone from being able to insert their hands, or foreign objects, into the valve when in operation.

Design Engineers • Technicians • Installers

SAFETY NOTICE