

SECTION 2 VALVES

Hopper-Top Diverter Valves – Series II



PRODUCT DESCRIPTION

The Hopper-Top Diverter Valve Series II is used to divert material from the convey line into a scale hopper or bin, while simultaneously allowing the conveying air to continue to be vented down the convey line. The unique transition design makes use of an 8-inch, resilient seated butterfly valve for diverting or bypassing the selected bin without leakage from the convey line while maintaining a minimal stack up height.

PRODUCT FEATURES

- Carbon steel or stainless steel housing construction
- NEMA 4, 4X, or 7/9
- Disk available in nickel-plated ductile iron, aluminum/bronze disk with stainless-steel shaft, or 316 stainless steel disk and shaft
- Valve body available in cast iron, aluminum/bronze, or 304 stainless steel
- Seat construction available in EPDM food-grade, white buna-n food-grade, or viton GF
- Most types of limit switches are available
- Valve alignment holes conform to 125-150# ASA pipe flange
- Minimum 80 PSI plant air required

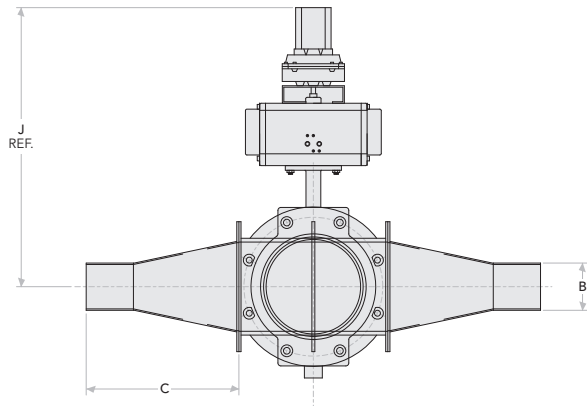

PLAN VIEW

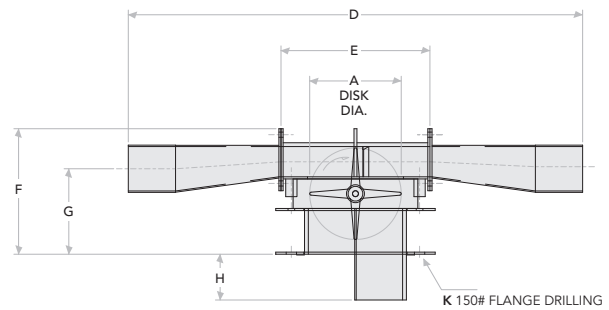

ELEVATION VIEW

Hopper-Top Diverter Valve — Series II

Dimensions (inches)

CONVEY LINE SIZE	A	B	C	D	E	F	G	H	J	K
2T	8	2	12-15/16	38-7/16	12-5/8	10-5/8	8-1/4	3-7/8	23-5/8	8
2P	8	2-3/8	12-15/16	38-7/16	12-5/8	10-5/8	8-1/8	3-7/8	23-5/8	8
3T	8	3	12-15/16	38-7/16	12-5/8	10-5/8	7-3/4	3-7/8	23-5/8	8
3P	8	3-1/2	12-15/16	38-7/16	12-5/8	10-5/8	7-9/16	3-7/8	23-5/8	8
4T	8	4	12-15/16	38-7/16	12-5/8	10-5/8	7-1/4	3-7/8	23-5/8	8
4P	8	4-1/2	12-15/16	38-7/16	12-5/8	10-5/8	7	3-7/8	23-5/8	8
5T	10	5	11-1/2	38-7/16	15-7/16	11-3/4	7-7/8	3-7/8	25-15/16	10
5P	10	5-9/16	11-1/2	38-7/16	15-7/16	11-3/4	7-3/4	3-7/8	25-15/16	10
6T	12	6	9-5/16	38-7/16	19-3/4	13-15/16	9-5/8	7-1/8	28-1/2	12
6P	12	6-5/8	9-5/16	38-7/16	19-3/4	13-15/16	9-3/16	7-1/8	28-1/2	12