



**MAGNUM**  
S Y S T E M S

2205 Jothi Avenue, Parsons, Kansas 67357  
Toll Free 888.882.9567 • Fax 620.421.5531  
[magnumsystems.com](http://magnumsystems.com)

**NOTICE**

**THIS ENVELOPE CONTAINS  
IMPORTANT DOCUMENTS**

**DO NOT DESTROY**

**SILDE DIVERTER VALVE**  
O&M DOCUMENTATION

**MODEL: SDV 2-WAY**  
*SIZES: 2" - 12"*

**N10-410**

# NOTICE

**THIS ENVELOPE CONTAINS  
IMPORTANT DOCUMENTS**

# DO NOT DESTROY



## SLIDE DIVERTER VALVE INSTALLATION & MAINTENANCE INSTRUCTIONS

**WARNING! READ ALL INSTRUCTIONS. FAILURE TO FOLLOW SAFETY RULES LISTED BELOW, AND OTHER BASIC SAFETY PRECAUTIONS, MAY RESULT IN SERIOUS PERSONAL INJURY!**

**WARNING!** When installing slide diverter valve DO NOT connect to the power source until flexible conveyer hose is in place and the diverter inlet and outlets are connected to piping so that there is no chance for fingers and hands to get close to moving slide plate.

**WARNING!** Disconnect Slide Diverter solenoid from power source before attempting to make any repairs. Follow proper lockout/tagout procedures. Moving parts can crush and cut. Keep hands clear while operating.

**DANGER!** Keep both the inlet and outlets connected to piping when the diverter is connected to a power source.

**DO NOT TRY TO FORCE THE DIVERTER TO SLIDE WITH YOUR HANDS!** After disconnecting power to Diverter, use the manual override on the solenoid to divert by hand. If the slide does not move relatively easy, look for the cause of the problem. Remember the Diverter is a precision piece of equipment and can be easily damaged if not handled properly by personnel trained to work on precision equipment. There are numerous reasons why the Diverter could be binding. If you are unable to find the problem yourself, consult Smoot trained factory personnel. It may be something that can be diagnosed over the phone. If not, you may have to send the Diverter to the Smoot factory or obtain the services of a trained Smoot technician.

**CAUTION!** All repairs, electrical or mechanical, should be attempted only by trained repairmen.

**STAY ALERT!** Watch what you are doing. Use common sense. Do not attempt to operate slide diverter without the inlet and outlet connections in place.

**THE PEOPLE, PARTS AND SYSTEMS THAT KEEP THE LINE MOVING.**



**SLIDE DIVERTER VALVE INSTALLATION AND  
MAINTENANCE INSTRUCTIONS**  
**Magnum Systems Series A37 Slide Diverter Valve (SDV)**  
**Ref. Magnum Systems Dwg. No. 37-2 and 37-4**

**GENERAL INFORMATION**

For all Magnum Systems Slide type Diverter Valves the same air that powers the air cylinder is also used to pressurize the air energized sealing rings.

Magnum Systems Slide Diverter Valves (SDV's) are supplied in two pressure ranges. One is for convey pressures at the SDV of 15 psig or less (Dilute Phase applications), and the other is for convey pressures at the SDV of over 15 psig to 100 psig and higher (Dense Phase applications).

**The Dense Phase SDV's have these additional features:**

- 1) More slide bearing blocks on the larger sizes.
- 2) Hose and fittings to withstand 100 psig.
- 3) A control air arrangement to the air energized sealing rings which will provide lower pressure air to the air energized sealing rings when the SDV is switching positions and then higher pressure air to the air energized sealing rings when the inlet port is centered over one of the outlet ports.
- 4) The inlet and outlet ports are supplied with Schedule 40 or greater pipe stubs (the 10 & 12" sizes may not require schedule 40 in some cases) and are machined to accept Victaulic couplings.

Magnum Systems recommends that conveying cease before switching the SDV from one outlet port to the other. The reason for this is because the SDV utilizes two air energized sealing rings around each outlet port to affect an airtight seal when the inlet port is centered over either outlet port. When the inlet port is in transition between the two outlet ports the air tight seal is temporarily lost and leakage can occur during this short time interval. This is of no concern to some of our customers but we always advise our customers that leakage will occur when switching under pressure conditions while conveying is in progress (this is especially true for HiPres dense phase SDV's). The leakage problem should not occur when switching while conveying under vacuum conditions.

**INSTALLATION**

- 1) Install in a manner that no undue stresses are placed upon the valve because of piping misalignment, i.e., accurately align the two outgoing pipe (tube) convey lines before attempting to couple them to the SDV outlet stubs.
- 2) Install the flexible (inlet side) hose so that the hose will not hit any obstruction when sliding from one outlet port to the other.

***THE PEOPLE, PARTS AND SYSTEMS THAT KEEP THE LINE MOVING.***



- 3) When mounting the valve, **DO NOT** weld to any portion of the valve. Use mounting holes provided or drill new ones if desired. If new holes are drilled, make sure bolts will not interfere with slide movement.
- 4) Supply 80-120 psig of clean, dry, air to inlet port of 4-way solenoid valve, which controls the SDV air cylinder. A lubricator is not required if Magnum Systems' standard solenoid valve and air cylinder is used.
- 5) The **Dilute Phase SDV** is supplied with a single air regulator to regulate the pressure to the sealing rings. It is factory set at 30 psig, which is good for most all dilute phase applications and provides long life to the sealing ring and the other mating surfaces. Pressures greater than 30 psig can be applied but at the cost of reduced cycle life of the sealing ring. The pressure remains on the sealing ring while the slide is shifting from outlet port to outlet port and there is therefore a tendency for the air energized seal ring to be forced up into the open inlet port as it passes over the air energized sealing rings.  
The **Dense Phase SDV** is supplied with a low pressure and a high-pressure air regulator so as to be able to regulate the air pressure to the air energized sealing rings at two different pressures. A 3-way solenoid valve is also supplied. All this is so that air energized sealing ring pressure is approximately 25 psig over convey line pressure when the SDV inlet port is centered over one of the outlet ports and then approximately 30 psig when the inlet port of the SDV is in transition between outlet ports. It is required that the customer must supply some external controls to accomplish this, all of which is explained in more detail on Magnum Systems drawing #37B-18.
- 6) Control power for solenoid is usually 115 volts A.C. Check purchase order or name tag on solenoid to verify.
- 7) Limit switches may be installed on valve to indicate position of valve.

## **MAINTENANCE**

- 1) Actuate valve from one position to other and note if action is smooth. If not smooth, air pressure on pressure regulator may be set too high, causing the air energized sealing rings to deflect up and catch on the inner diameter of the inlet port as it passes by.
- 2) It is perfectly normal for dusting to occur when the SDV is diverting from one position to the other while conveying under pressure conditions. You will have to cease conveying and purge the convey line before you can divert from one position to the other without dusting.
- 3) If dusting is noticed from SDV when the inlet port is centered over one of the outlet ports, it may be an indication of worn seal rings or air pressure on seal ring is set too low.
- 4) Failure to move at all may be a bad solenoid, lack of air pressure, or air cylinder failure. Bad misalignment of piping can cause failure also.
- 5) If air energized seal rings need replacing considerable care needs to be taken that the O-rings do not get cut in the process of reinstalling the seal rings. It is a good idea to use a lubricant.

***THE PEOPLE, PARTS AND SYSTEMS THAT KEEP THE LINE MOVING.***



- 6) When ordering parts for high temperature valves, be sure to advise that parts are for a high temperature application.

## **O-RING SEALS AND RETAINING RING REPLACEMENT**

Retaining Rings are typically made of Delrin or Stainless Steel material. 2"-6" Slide Diverter Valves use Delrin and 8"-12" Slide Diverter Valves use Stainless Steel. Each retaining ring is a precision-machined component that houses two (2) O-rings.

- 1) Slide Dis-assembly:
  - a. Slide diverter valve air cylinder should be positioned in the retracted position.
  - b. Remove locking nut and hex nut from air cylinder push bar assembly.
  - c. Loosen and remove all eccentric hex bolts from slide bearings and remove slide bearings.
  - d. Move the slide away from the air cylinder to dis-engage the air cylinder push rod from the slide assembly.
  - e. Lift the slide out of the slide diverter valve frame/
- 2) Removal of retaining ring and o-ring asy:

DO NOT USE SHARP OBJECTS TO DIG OUT THE RETAINING RING ASSEMBLY.

  - a. Drill a small 1/16"-1/8" diameter hole approx. 1/4" deep in two locations on the face of the retaining ring 180 deg apart.
  - b. Thread a screw into each of the holes that were drilled.
  - c. Pull on the screws to remove the retaining ring assembly.

OR

Apply compressed air momentarily to the bottom side of the o-ring retainer assembly. This should push the o-ring retaining assembly out of the body.
- 3) Installation of retaining ring and o-ring asy:
  - a. Place one (1) o-ring on the outside and one (1) o-ring in the inside of the retaining ring in the machined grooves.
  - b. Press the O-ring retaining assembly back into the slide diverter valve body. Care should be taken while performing this operation. The O-rings should be well lubricated with a lightweight oil. Avoid shearing or pinching of the O-rings between the retaining ring and slide housing. When installing the O-ring retaining assembly into the slide housing, carefully use a small flat head screwdriver to work the top of the o-ring while applying constant pressure on the retaining ring.
- 4) Slide Re-assembly:
  - a. Place the slide onto the body and loosely reconnect the slide to the air cylinder push rod.

***THE PEOPLE, PARTS AND SYSTEMS THAT KEEP THE LINE MOVING.***



- b. Re-install the slide bearings and eccentric bolts loosely into the slide diverter valve frame.
- c. Rotate the eccentric bolts while using a .006 thick shim between the slide and the body. Tighten the eccentric bolt nuts while holding the eccentric bolt in position to ensure a .005-.007 in clearance between the slide and body. Repeat for all bearing block locations.
- d. Align the inlet stub of the slide directly over the first outlet stub port on the body. Use the hex nuts on the air cylinder push bar to adjust alignment and secure the slide in position directly over the first outlet stub.
- e. Connect hi pressure air-to-air cylinder assembly.
- f. Connect 110v power to solenoid.
- g. Energize solenoid to ensure proper alignment of slide stub directly over both outlet stubs.
- h. Re-check clearances between slide and body using a .006 thick shim to verify .005-.007 in. clearance when slide is in both positions.

***THE PEOPLE, PARTS AND SYSTEMS THAT KEEP THE LINE MOVING.***



---

## **AIR CYLINDER CHANGE ON 2 WAY SDV**

OLD STYLE (all silver including end caps)		NEW STYLE (After '09) (black end caps)
2"	A15-015	A15-110
3"	A15-025	A15-120
4"	A15-035	A15-130
5"	A15-045	A15-140
6"	A15-055	A15-150
8"	A15-065	A15-160
10"	A15-075	A15-170
12"	A15-085	A15-180

## **AIR CYLINDER ON 3 WAY SDV**

2"	A15-005
3"	A15-017
4"	A15-037
5"	A15-038
6"	A15-057

***THE PEOPLE, PARTS, AND SYSTEMS THAT KEEP THE LINE MOVING.***



ASSEMBLY

ITEM	QTY	DESCRIPTION
1	1	SLIDE DIVERTER VALVE FRAME
2	1	VALVE BODY
3	1	SLIDE
4	C	SLIDE BEARING
5	1	INLET STUB
6	1	PUSH BAR
7	2	HEX HEAD BOLTS
8	2	FLAT WASHER
9	2	LOCK WASHER
10	1	1/4 NPT 90 DEG. 1/4 HOSE CONNECTION
11	1	1/8 NPT STRAIGHT 1/4 HOSE CONNECTION
12	1	1/4 NPT 90 DEG 3/8 HOSE CONNECTION
13	1	1/4 STRAIGHT 3/8 HOSE CONNECTION
14	1	SOLENOID VALVE
15	1	CLEVIS PIN
16	1	AIR CYLINDER
17	2	OUTLET STUB
18	2	RETAINER RING
19	4	O-RING
20	3	CLOSE 1/4 NPT PIPE NIPPLE
21	C	ECCENTRIC BOLT
22	C	HEX NUT
23	C	FLAT WASHER
24	1	STANDARD PIPE TEE
25	1	REGULATOR VALVE
26	1	GAUGE
27	1	THREADED ROD
28	5	JAM NUT
29	1	3/8 NPT STREET ELBOW
30	AR	3/8 TUBE
31	AR	1/4 POLY TUBE
32	2	MAGNETIC REED SWITCH
33	1	3/8-1/4 NPT HEX REDUCER BUSHING

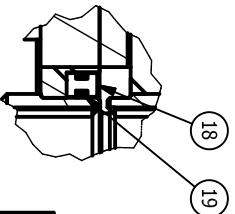
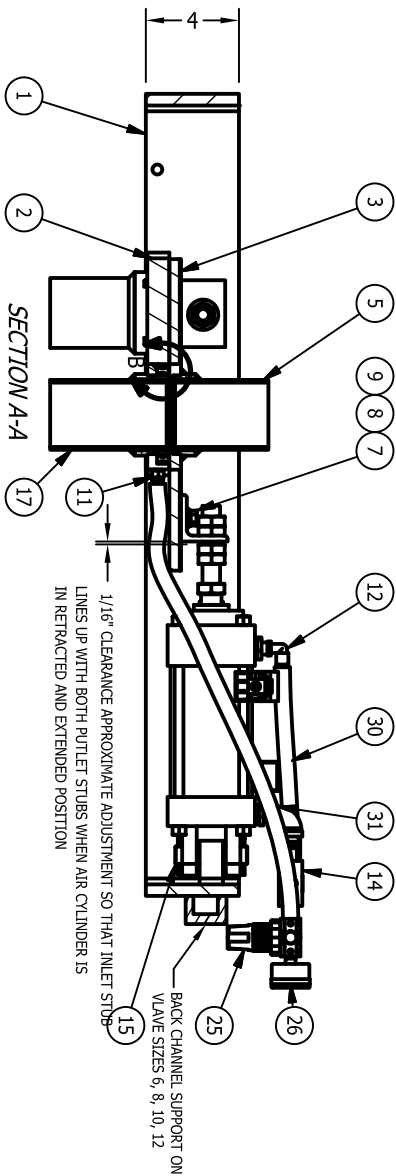
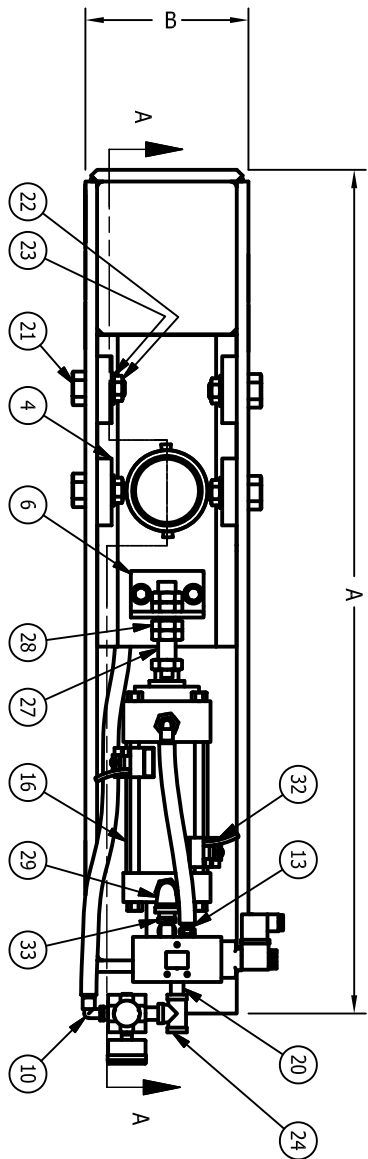

DETAIL B

DIMENSIONS/AMOUNTS			
BASIC VALVE SIZE	A	B	C
2	27 3/4"	6"	4
3	34 7/16"	7"	4
4	41 1/16"	8"	4
5	46 5/16"	9"	4
6	51 1/2"	10"	4
8	62 3/4"	12"	6
10	74 1/2"	14 1/2"	6
12	83 9/16"	16 1/2"	6

**MAGNUM SYSTEMS**  
 2020 S. WYOMING AVE. SUITE 100  
 LAWRENCE, KS 66044  
 Phone 785.882.2857  
 Fax 785.882.2857

**MAGNUM SYSTEMS**  
 2020 S. WYOMING AVE. SUITE 100  
 LAWRENCE, KS 66044  
 Phone 785.882.2857  
 Fax 785.882.2857

**MAGNUM SYSTEMS**  
 2020 S. WYOMING AVE. SUITE 100  
 LAWRENCE, KS 66044  
 Phone 785.882.2857  
 Fax 785.882.2857

**MAGNUM SYSTEMS**  
 2020 S. WYOMING AVE. SUITE 100  
 LAWRENCE, KS 66044  
 Phone 785.882.2857  
 Fax 785.882.2857

**MAGNUM SYSTEMS**  
 2020 S. WYOMING AVE. SUITE 100  
 LAWRENCE, KS 66044  
 Phone 785.882.2857  
 Fax 785.882.2857

**MAGNUM SYSTEMS**  
 2020 S. WYOMING AVE. SUITE 100  
 LAWRENCE, KS 66044  
 Phone 785.882.2857  
 Fax 785.882.2857

**MAGNUM SYSTEMS**  
 2020 S. WYOMING AVE. SUITE 100  
 LAWRENCE, KS 66044  
 Phone 785.882.2857  
 Fax 785.882.2857

**MAGNUM SYSTEMS**  
 2020 S. WYOMING AVE. SUITE 100  
 LAWRENCE, KS 66044  
 Phone 785.882.2857  
 Fax 785.882.2857

**MAGNUM SYSTEMS**  
 2020 S. WYOMING AVE. SUITE 100  
 LAWRENCE, KS 66044  
 Phone 785.882.2857  
 Fax 785.882.2857

SAFETY FIRST

SLIDE DIVERTER  
VALVE

**SAFETY**

## SLIDE DIVERTER VALVE SAFETY PROCEDURES

Prevent damage to yourself and your new Slide Diverter by following these simple safety procedures.

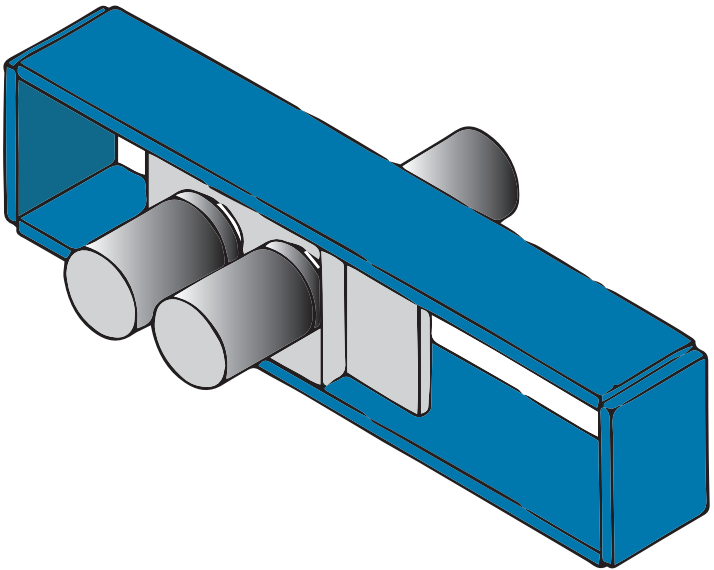



---

## ALWAYS

DISCONNECT power and remove the roller chain BEFORE working on the valve.

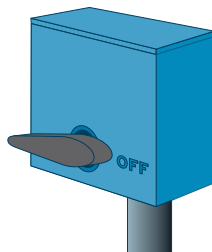

---

## NEVER

Put HANDS into the inlet or outlet openings of the valve.

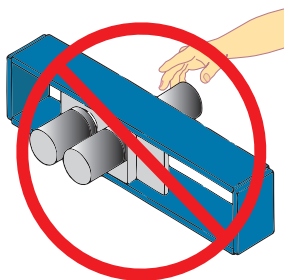

---

## ALWAYS

Have inlet and outlet pipes PROPERLY CONNECTED when operating valve.

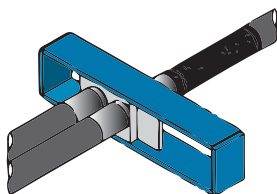

---

## NEVER

Perform maintenance on valve while it is in service.

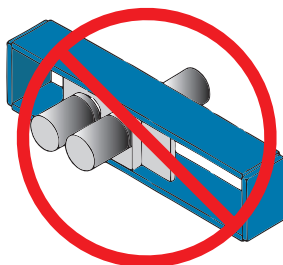

## SAFETY FIRST

Slide Diverter Valves are powerful and can be dangerous if you do not follow procedures. Prevent damage to yourself and your new Slide Diverter by following these simple safety procedures.

© Magnum Systems all rights reserved 2018. MS.4022.0519



Toll Free: 888.882.9567  
Visit: [magnumsystems.com](http://magnumsystems.com)

2205 Jothi Avenue  
Parsons, Kansas 67357