

ASSEMBLY

ITEM	QTY	DESCRIPTION
1	1	SLIDE DIVERTER VALVE FRAME
2	1	VALVE BODY
3	1	SLIDE
4	C	SLIDE BEARING
5	1	INLET STUB
6	1	PUSH BAR
7	8	HEX HEAD BOLT
8	8	FLAT WASHER
9	8	LOCK WASHER
10	2	1/4 NPT 90 DEG. 1/4 HOSE CONNECTION
11	1	1/8 NPT STRAIGHT 1/4 HOSE CONNECTION
12	3	1/4 NPT 90 DEG. 3/8 HOSE CONNECTION
13	3	1/4 STRAIGHT 3/8 HOSE CONNECTION
14	1	SOLENOID VALVE
15	1	AIR CYLINDER
16	3	OUTLET STUB
17	3	RETAINER RING
18	6	O-RING
19	3	CLOSE 1/4 NPT PIPE NIPPLE
20	C	ECCENTRIC BOLT
21	C	HEX NUT
22	C	FLAT WASHER
23	1	STANDARD PIPE CROSS
24	1	REGULATOR VALVE
25	1	GAUGE
26	4	JAM NUT
27	1	3/8 NPT STREET ELBOW
28	AR	3/8 TUBE 1
29	AR	3/8 TUBE 2
30	AR	3/8 TUBE 3
31	AR	3/8 TUBE 4
32	AR	1/4 POLY TUBE
33	3	MAGNETIC REED SWITCH
34	1	3/8 - 1/4 NPT HEX REDUCER BUSHING
35	1	TOP PINCH GUARD RAIL
36	1	INLET TUBE PINCH GUARD PLATE
37	2	PINCH GUARD PLATE
38	2	PLASTIC BELLOW
39	1	BOTTOM PINCH GUARD
40	6	THUMB SCREW

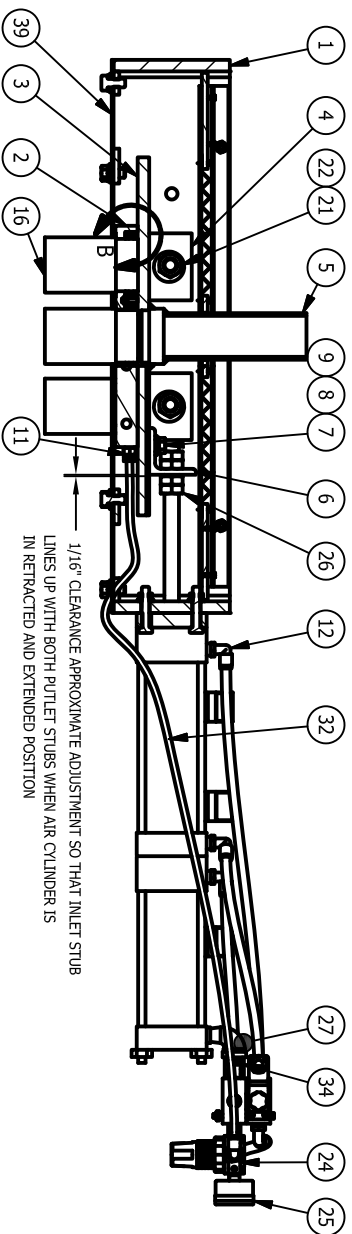

SECTION A-A

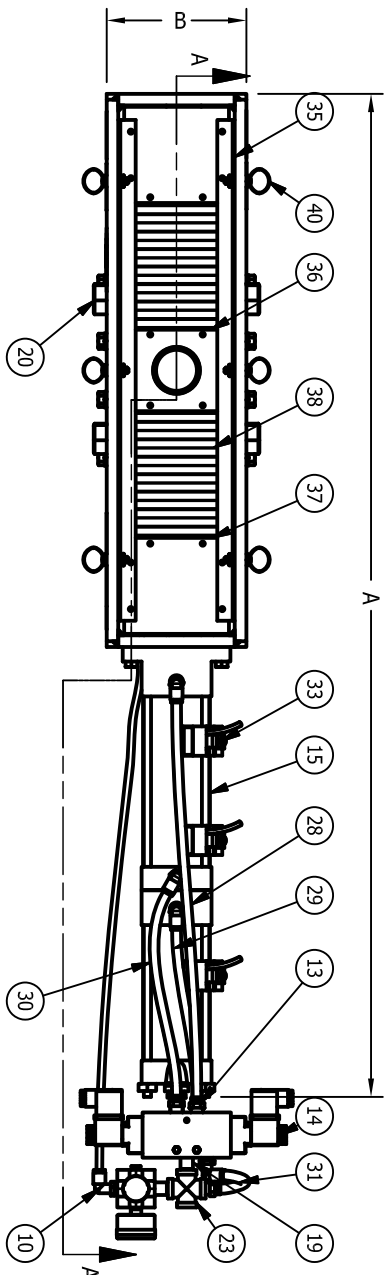
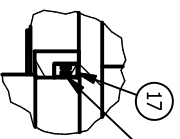

DETAIL B

DIMENSIONS/AMOUNTS			
BASIC VALVE SIZE	A	B	C
2"	42 3/4	6	4
3"	55 3/4	7	4
4"	69 5/16	8	6
5"	79 5/16	9	6
6"	90 5/16	10	6

BEFORE THE CUSTOMER
 INSTALLS THE DRAWING AS A
 WHOLE OR PARTS THEREOF,
 CORRECTIONS OR REVISIONS
 TO THE DRAWING SHALL BE
 MADE BY THE CUSTOMER.
 MAGNUM SYSTEMS TO BE
 IMPLEMENTED.
 DIMENSIONS ARE IN INCHES
 UNLESS OTHERWISE SPECIFIED.
 TOLERANCES:
 FRACTIONAL ± 1/16
 DECIMAL .XX ± .005
 DECIMAL .XXX ± .002
 ANGLES ± 0.5 DEG
 THIRD ANGLE PROJECTION

MAGNUM SYSTEMS
 2501 S. W. 10TH AVE., SUITE 100
 MIAMI, FL 33155
 PHONE: 305.444.1531
 FAX: 305.444.1531

MAGNUM SYSTEMS
 2501 S. W. 10TH AVE., SUITE 100
 MIAMI, FL 33155
 PHONE: 305.444.1531
 FAX: 305.444.1531

3-WAY SLIDE DIVERTER VALVE PARTS DRAWING
 MODEL: 38-79
 DRAWN BY: SDC DATE: 5/14/2019
 APPR. BY: SLM DATE: 5/15/2019
 CHECKED BY: SDC DATE: 5/15/2019
 SCALE: NTS SHEET: 1 of 1

THIS DRAWING IS THE SOLE PROPERTY OF MAGNUM SYSTEMS. ITS ACCEPTANCE CONSTITUTES AN AGREEMENT THAT IT SHALL BE TREATED AS A STRICTLY CONFIDENTIAL DOCUMENT AND IS TO BE KEPT IN STRICTLY CONFIDENTIAL STORAGE. LOANED OR COPIED WITHOUT EXPRESSLY AUTHORIZED WRITING BY MAGNUM SYSTEMS.