



ROBOTIC PALLETIZER TOOLING

MODEL MRPT

ROBOTICS EXPERIENCE

Magnum Systems Inc. has been in the robotic palletizing and bag placing market since 2004 with the introduction of the TRV-1000 Valve Bag Placer, followed by the TRP-3000 Bag Palletizer in 2005, and the TRD-2000 Buckhorn Box de-nester in 2014. Over the years, the number of robotic arm manufacturers has grown to almost commodity levels, but efficient programming and container manipulation experience are constant requirements for a successful application. Magnum continues to be a leader in these quality applications.

EFFICIENT PROGRAMMING

At the root of each application is a custom program based on the container size(s), number of functions required, system layout, and space limitations. The Magnum team determines the most efficient motions for the robotic arm and tooling to provide the safest, most reliable, and most productive operation of the robot.

APPLICATION EXPERIENCE

For more than 47 years, Magnum has designed and installed packaging lines. These lines fill everything from 4,000 lb FIBCs to 4 oz pouches. We understand the type of container, dimensions, and desired capacity is only the first step of the application solution. Our experts also understand that robotic equipment applications may ask the robot to handle more than just containers and more than just one function. Magnum's Robotic Palletizer Tool, is designed by container-handling experts to meet each custom application.

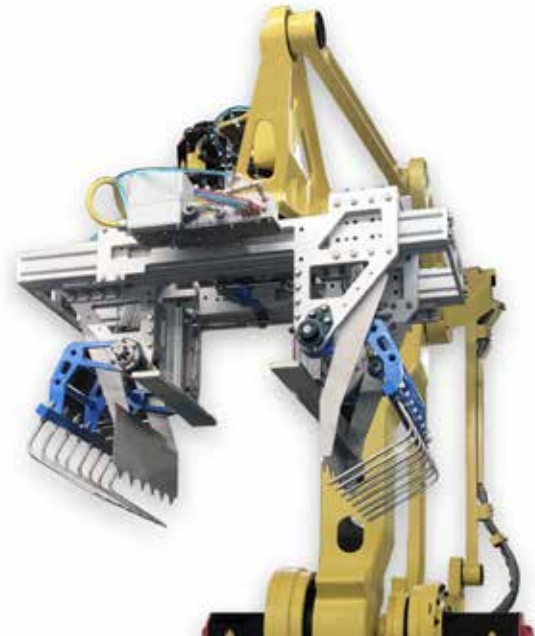

UPGRADE YOUR END-OF-ARM TOOLING WITH MAGNUM'S NEW MODEL MRPT

Features

- Auto adjustment on the fly
- Linear bag squaring
- Proof of position indication

Benefits

- Increase process line efficiency
- Precise bag placement on pallet
- All functions are proofed back to the robot, for justification on a fully automated line

One Partner For All Your Material Handling Needs.

ROBOTIC PALLETIZER TOOLING

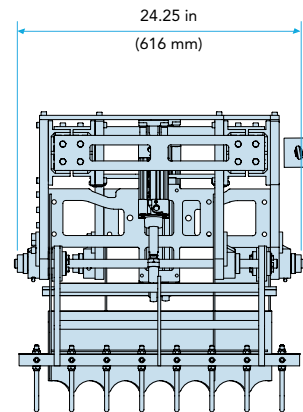
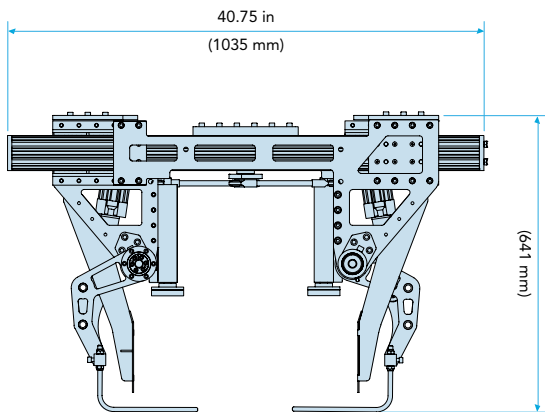
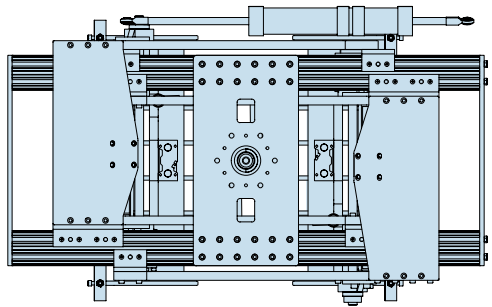

Diagram dimensions are for reference only*

BAG-HANDLING CAPABILITIES

Weight	35 to 100 lb (15.88 to 45.36 kg)
Length	14 to 40 in (355.6 to 1016 mm)
Width	14 to 20.5 in (355.6 to 520.7 mm)
Thickness	3.5 to 7 in (88.9 to 177.8 mm)
Rate	Varies based on application



PALLET ACCESSORY

- Retrieve and place empty pallet
- Pallet present sensor
- Ensures pallet is in correct position for picking and placing



SLIP SHEET ACCESSORY

- Retrieve and place slip sheet on pallet
- Single-source vacuum suction
- Pressure Indication Sensor for loss of suction
- Blow off capability ensures slip sheet is quickly and positively released



©2024 Magnum Systems, Inc. All rights reserved. Catalog number MS.1052.0824



www.magnumsystems.com

Toll Free 800.748.7000 Fax 913.362.7863
7945 Flint Street, Lenexa, KS 66214