

Taylor Products Model TE100 Electronic Small Bagging Scale

Operation and Maintenance Manual



**Taylor Products
a division of Magnum Systems
2205 Jothi Avenue
Parsons, Kansas 67357-8460
Toll Free: 888-882-9567
Phone: 620-421-5550
Fax: 620-421-5531**

**Web: www.taylorproducts.com
customerservice@magnumsystems.com**

Machine Serial Number: _____

Sales Order Number: _____

Important Information

Conventions

Safety Alert Symbols

The  symbol indicates that important personal safety information follows. Carefully read this text for the warnings information it contains. The signal word next to each safety alert symbol is defined as:

**WARNING**

Indicates a potentially hazardous situation that, if not avoided, could result in death or serious injury.



**CAUTION**

Indicates a potentially hazardous situation that, if not avoided, may result in minor or moderate injury, or damage to the equipment. This single word may also be used to identify unsafe practices.

**LOCKOUT**

This symbol will be used anytime that a procedure requires an electrical lockout.

Static Sensitive Symbols for Equipment Handling Instructions

The  and  symbols indicate important handling guidelines for proper handling of electronic equipment modules and sensitive components for the prevention of potential damage that could be caused by ESD (electrostatic discharge) during routine maintenance, handling and transportation.

**ESD NOTICE**

To protect against ESD damage to electronic equipment, follow the Standard ESD Prevention Procedures. Failure to use protective measures could result in permanent equipment damage, either immediate or latent, when handling modules.

**ESD NOTICE**

To protect against ESD damage to electronic equipment containing components, follow the Standard ESD Prevention Procedures. Failure to use recommended protective measures could result in permanent equipment damage, either immediate or latent, when handling components.

Standard Electro-Static Discharge (ESD) Prevention Procedures

The Model TE100 Electronic Small Packer utilizes many electronic components that are susceptible to damage from Electro-Static Discharge. Anytime electronic components are serviced, the following precautions should be followed:

1. Wear a commercial grounding wrist strap.
2. Remove power from the machine.
3. Leave all static sensitive components in their protective packaging until it is time to install the component
4. Always hold static sensitive components by their metal mounting tabs, and/or by their edges

Important/Notable Information

While all of the information in this manual is important, there are some pieces of information where special attention needs to be paid to avoid equipment damage, or specific information needs to be emphasized. This information will be handled as follows:

Important: Indicates an operating procedure, practice, or condition that, if not strictly followed, may cause equipment damage.

Note: Indicates additional information or emphasizes a topic related to the subject being discussed.

Personal Safety Instructions

Only qualified personnel should work on or around this equipment. To ensure the highest degree of personal safety, all who use this equipment are required to become thoroughly familiar with all safety instructions contained in this document. Successful and safe operation of this equipment depends upon proper handling, operation, maintenance, and application of associated equipment. Refer to Appendix A of this manual for all safety instructions. Safety instructions are also provided where they apply within the body of this manual.



WARNING

No information in this manual supersedes or replaces your employer's operating rules. If there is a difference in instructions between this manual and the employer's operating rules, follow the most restrictive instruction.

Deliberate misuse or abuse of electronic components may cause personal injury or death.

Warranty Information

Seller warrants that the Products will operate substantially in conformance with Seller's published specifications, when subjected to normal, proper and intended usage by properly trained personnel, for a period of one (1) year from the date of shipment to Buyer (the "Warranty Period"). Seller agrees during the Warranty Period, provided it is promptly notified in writing upon the discovery of any defect and further provided that all costs of returning the defective Products to Seller are pre-paid by Buyer, to repair or replace, at Seller's option, defective Products so as to cause the same to operate in substantial conformance with said specifications. Replacement parts may be new or refurbished, at the election of Seller. All replaced parts shall become the property of Seller. Replacement Parts will be billed at list price, unless they are approved as warranty replacement item(s) by the service technician and the technical services manager.

Lamps, fuses, bulbs and other expendable items are expressly excluded from the warranty. Seller's sole liability with respect to equipment, materials, parts or software furnished to Seller by third party suppliers shall be limited to the assignment by Seller to Buyer of any such third party supplier's warranty, to the extent the same is assignable. In no event shall Seller have any obligation to make repairs, replacements or corrections required, in whole or in part, as the result of (i) normal wear and tear, (ii) accident, disaster or event of force majeure, (iii) misuse, fault or negligence of or by Buyer, (iv) use of the Products in a manner for which they were not designed, (v) causes external to the Products such as, but not limited to, power failure or electrical power surges, (vi) improper storage of the Products or (vii) use of the Products in combination with equipment or software not supplied by Seller. If Seller determines that Products for which Buyer has requested warranty services are not covered by the warranty hereunder, Buyer shall pay or reimburse Seller for all costs of investigating and responding to such request at Seller's then prevailing time and materials rates. If Seller provides repair services or replacement parts that are not covered by the warranty, the Buyer shall pay Seller therefore at Seller's then prevailing time and materials rates. ANY INSTALLATION, MAINTENANCE, REPAIR, SERVICE, RELOCATION OR ALTERATION TO OR OF, OR OTHER TAMPERING WITH, THE PRODUCTS PERFORMED BY ANY PERSON OR ENTITY OTHER THAN SELLER WITHOUT SELLER'S PRIOR WRITTEN APPROVAL, OR ANY USE OF REPLACEMENT PARTS NOT SUPPLIED BY SELLER, SHALL IMMEDIATELY VOID AND CANCEL ALL WARRANTIES WITH RESPECT TO THE AFFECTED PRODUCTS.

Field Service

Taylor Products can provide field service for start-up assistance, training, maintenance, and replacement/spare parts for new and existing equipment. Contact Taylor Products at (888) 882-9567 for more information.

This Page Intentionally Left Blank

TE100 Electronic Small Bagging Scale

Table of Contents

Chapter	Page
1 Product Description	1-1
1.1 General Description	1-1
1.2 Introduction.....	1-1
1.3 Manual Scope.....	1-1
1.4 Electrical Requirements.....	1-1
1.5 Pneumatic Requirements	1-1
1.6 Major Systems and Components	1-2
1.6.1 Scale Cabinet Assembly	1-3
1.6.1.1 Scale Cabinet.....	1-3
1.6.1.2 Shut Off Gate.....	1-4
1.6.1.3 Shut Off Gate Bearings	1-4
1.6.1.4 Shut Off Gate Cylinder.....	1-4
1.6.1.5 Dribble Gate	1-4
1.6.1.6 Dribble Gate Cylinder	1-4
1.6.1.7 Dribble Gate Mounting Rails	1-4
1.6.1.8 Load Cell	1-4
1.6.1.9 MAC Valves.....	1-5
1.6.1.10 Filter/Regulator/Lubricator (FRL) Assembly.....	1-6
1.6.1.11 Control Box	1-6
1.6.2 Spout assembly	1-7
1.6.2.1 Spout.....	1-7
1.6.2.2 Bag Clamp Arms	1-8
1.6.2.3 Bag Clamp Cylinders	1-9
1.6.2.4 Bag Clamp Pads	1-9
1.6.2.5 Start Switch	1-10
1.6.2.6 Bag Position Switch	1-10
1.6.2.7 Optional Small Bag Adapter	1-11
2 Receiving Equipment.....	2-1
2.1 General Description	2-1
2.2 Uncrating the Equipment	2-1
3 Setup/Installation	3-1
3.1 General Description	3-1
3.2 Mechanical Setup.....	3-2
3.3 Making Electrical Connections.....	3-3
3.3.1 Electrical Connections.....	3-3
3.3.2 Load Cell Connections	3-6
3.4 Making Pneumatic Connections	3-6
3.4.1 Lubrication Requirements	3-6
3.5 Dry Cycle	3-7

3.6	Calibration	3-7
3.6.1	Pre-Calibration Mechanical Checks	3-9
3.6.2	Calibrating the T4000 Control Panel	3-10
3.6.3	Dribble Gate Setup	3-13
3.6.4	Setting Auto Adjust Cutoff	3-14
3.6.4.1	Turning Auto Adjust Cutoff On/Off	3-14
3.6.4.2	Setting the Auto Adjust Limit	3-14
3.7	Installing the Optional Small Bag Adapter	3-15
4	Operation	4-1
4.1	General Description	4-1
4.2	Operational Controls	4-1
4.2.1	T4000 Control Panel Features	4-2
4.2.1.1	Entering Numbers Using The Control Panel	4-2
4.2.2	T4000 Menu System	4-4
4.2.2.1	Tare Weight Menu	4-6
4.2.2.2	Manual Zero Function	4-7
4.2.2.3	Target Min/Max Menu	4-7
4.2.2.4	Hysteresis Menu	4-8
4.2.2.5	Setup Menu	4-8
4.2.2.6	Calibration Menu	4-11
4.2.2.7	Test Menu	4-11
4.2.2.8	Security Menu	4-11
4.3	Initial Setup	4-12
4.4	Normal Operation (Typical Fill Cycle)	4-13
4.4.1	Maintaining Operational Efficiency	4-13
5	Preventive Maintenance	5-1
5.1	General Description	5-1
5.2	Daily Maintenance Procedures	5-1
5.2.1	Cleaning	5-1
5.2.2	Check Calibration	5-1
5.3	Monthly Maintenance	5-1
6	Troubleshooting	6-1
6.1	General Description	6-1
6.2	The Troubleshooting Process	6-1
6.3	Trouble Symptoms	6-1
6.3.1	Scale is Not Accurate	6-1
6.3.2	Scale Does Not Return to Zero	6-2
6.3.3	The Machine Is Unable To Auto Correct To The Target Weight	6-2
6.3.4	The Weighments Fluctuate Between Too Light and Too Heavy	6-2
6.3.5	Filled Bag Won't Drop	6-2
6.3.6	Bag Won't Stop Filling	6-3
6.3.7	Pneumatic Cylinder Failure	6-3
6.3.8	MAC Valve Failure	6-3

7	Repair and Adjustment	7-1
7.1	General Description	7-1
7.2	System Adjustments	7-1
7.2.1	Bag Clamp Adjustment	7-1
7.2.2	Shut Off Gate Adjustment	7-2
7.2.3	MAC Valve Flow Control Adjustment	7-3
7.3	System Repairs	7-4
7.3.1	Spout Replacement	7-4
7.3.1.1	Spout Removal	7-4
7.3.1.2	Spout Installation.....	7-5
7.3.2	Load Cell Replacement.....	7-6
7.3.2.1	Load Cell Removal.....	7-6
7.3.2.2	Load Cell Installation	7-6
7.3.3	Dribble Gate Cylinder Replacement.....	7-7
7.3.3.1	Dribble Gate Cylinder Removal.....	7-7
7.3.3.2	Dribble Gate Cylinder Installation	7-7
7.3.4	Dribble Gate Replacement.....	7-7
7.3.4.1	Dribble Gate Removal.....	7-7
7.3.4.2	Dribble Gate Installation	7-7
7.3.5	Shut Off Gate Cylinder Replacement.....	7-8
7.3.5.1	Shut Off Gate Cylinder Removal	7-8
7.3.5.2	Shut Off Gate Cylinder Installation.....	7-8
7.3.6	Shut off Gate Replacement.....	7-8
7.3.6.1	Shut Off Gate Removal	7-8
7.3.6.2	Shut Off Gate Installation.....	7-9
7.3.7	Shut Off Gate Seal Replacement	7-10
7.3.7.1	Shut Off Gate Seal Removal	7-10
7.3.7.2	Shut Off Gate Seal Installation.....	7-10
7.3.8	Bag Clamp Arm Replacement.....	7-10
7.3.8.1	Bag Clamp Arm Removal	7-10
7.3.8.2	Bag Clamp Arms Installation	7-11
7.3.9	Bag Clamp Arm Spring Replacement	7-12
7.3.9.1	Bag Clamp Arm Spring Removal.....	7-12
7.3.9.2	Bag Clamp Arm Spring Installation	7-13
7.3.10	Bag Clamp Cylinder Replacement	7-13
7.3.10.1	Bag Clamp Cylinder Removal.....	7-13
7.3.10.2	Bag Clamp Cylinder Installation	7-13
7.3.11	Bag Clamp Pivot Block Replacement	7-14
7.3.11.1	Bag Clamp Pivot Block Removal.....	7-14
7.3.11.2	Bag Clamp Pivot Block Installation	7-14
7.3.12	Air Supply Line Replacement	7-15
7.3.12.1	Air Supply Line Removal.....	7-15
7.3.12.2	Air Supply Line Installation	7-15
7.3.13	Pneumatic Quick Connect Fitting Replacement.....	7-15
7.3.13.1	Pneumatic Quick Connect Fitting Removal	7-15
7.3.13.2	Pneumatic Quick Connect Fitting Installation	7-16

Glossary Glossary-1

Index Index-1

Appendix A Safety Procedures, Cautions, Warnings, and Notices A-1

Appendix B Spare Parts B-1

Appendix C Mechanical Drawings C-1

Appendix D Electrical Drawings D-1

Appendix E Seed Count Option..... E-1

 General Description.....E-1

 Setup ProceduresE-1

 Changing The Instrument TypeE-1

 Entering ParametersE-3

 Setting The Target Weight.....E-5

List of Figures

Figure	Page
Figure 1-1. TE100 Front View.....	1-2
Figure 1-2. Scale Cabinet and Shut Off Gate	1-3
Figure 1-3. Load Cell.....	1-4
Figure 1-4. MAC Valves.....	1-5
Figure 1-5. MAC Valve Flow Adjustment	1-5
Figure 1-6. Filter/Regulator/Lubricator (FRL) Assembly	1-6
Figure 1-7. Control Panel.....	1-6
Figure 1-8. Spout Assembly – Side View.....	1-7
Figure 1-9. Chain Links and Pivot Block	1-8
Figure 1-10. Bag Clamp Arm – Shown With Stainless Steel Deflector.....	1-8
Figure 1-11. Bag Clamp Cylinder (1 of 2 Shown).....	1-9
Figure 1-12. Bag Clamp Pads	1-9
Figure 1-13. Start Switch	1-10
Figure 1-14. Bag Position Switch	1-10
Figure 1-15. TE100 With Small Bag Adapter Installed	1-11
Figure 2-1. Typical Shipping Box (2 Boxes Shown).....	2-1
Figure 3-1. Mounting the TE100	3-1
Figure 3-2. Hanging the Cabinet Assembly on the Hopper Flange.....	3-2
Figure 3-3. Shipping Bracket Location.....	3-2
Figure 3-4. MAC Valve Connections and Schematic.....	3-3
Figure 3-5. Connection Diagram	3-4
Figure 3-6. Wiring Diagram	3-5
Figure 3-7. Load Cell Connections.....	3-6
Figure 3-8. Lubricator – Oil Flow Control Knob	3-6
Figure 3-9. Control Panel.....	3-8
Figure 3-10. Load Passing Through Load Cell.....	3-9
Figure 3-11. Placing the Cursor In Front Of Calibration.....	3-10
Figure 3-12. Placing The Cursor In Front Of Trad Cal	3-10
Figure 3-13. Placing The Cursor In Front Of Zero Value	3-10
Figure 3-14. Span Value Displayed.....	3-11
Figure 3-15. Hanging A Certified Test Weight On The TE100	3-12
Figure 3-16. Dribble Gate Cylinder Mounting	3-13
Figure 4-1. Control Box.....	4-1
Figure 4-2. T4000 Control Panel	4-2
Figure 4-3. Cursor Positioned Below Digit On Right.....	4-2
Figure 4-4. Operator Has Pressed The Up Arrow Causing Digit On Right To Increase To 4	4-3
Figure 4-5. Operator Has Pressed The Left Arrow Moving Cursor Over 1 Position	4-3
Figure 4-6. Operator Has Pressed The Down Arrow Causing Center Digit Decrease To 1.....	4-3
Figure 4-7. T4000 Menu System Block Diagram.....	4-4
Figure 4-8. Dribble Weight.....	4-4
Figure 4-9. Cutoff Menu	4-5
Figure 4-10. Target Weight Menu	4-5
Figure 4-11. Configuration Menu, Tare Weight Setting and Manual Zero Function Shown.....	4-5
Figure 4-12. Configuration Menu, Target Min/Max and Hysteresis Options Shown	4-6
Figure 4-13. Configuration Menu, Setup and Calibration Options Shown	4-6

Figure 4-14. Configuration Menu, Test and Security Options Shown	4-6
Figure 4-15. Tare Weight Menu	4-6
Figure 4-16. Manual Zero Function.....	4-7
Figure 4-17. Target Min/Max Menu, Max and Min Settings Shown	4-7
Figure 4-18. Target Min/Max Menu, Auto-Adjust Cutoff and Limit Settings Shown.....	4-7
Figure 4-19. Hysteresis Menu.....	4-8
Figure 4-20. Setup Menu, Units and Decimal Point Settings Shown.....	4-9
Figure 4-21. Setup Menu, Num Averages and WEVERSAVER Settings Shown.....	4-10
Figure 4-22. Setup Menu, Low Pass Filter and Wait Time(s) Settings Shown.....	4-10
Figure 4-23. Setup Menu, Motion Tolerance and Instrument Type Settings Shown	4-10
Figure 4-24. Setup Menu, Instrument Type and Contrast Settings Shown	4-10
Figure 4-25. Calibration Menu, Trad Cal Highlighted	4-11
Figure 7-1. Bag Clamp Cylinder and Pivot Block Location.....	7-1
Figure 7-2. Shut Off Gate Adjustment.....	7-2
Figure 7-3. Adjusting Airflow From The MAC Valve.....	7-3
Figure 7-4. Bag Clamp Cylinder Air Supply Lines (1 Side Shown)	7-4
Figure 7-5. Spout Mounting Bolts	7-5
Figure 7-6. Checking Load Cell Alignment (As Viewed From The Top Of The TE100)	7-6
Figure 7-7. Shut Off Gate Mounting.....	7-9
Figure 7-8. Shut Off Gate Mounting Screw Ground Off Smooth	7-9
Figure 7-9. Shut Off Gate Seal	7-10
Figure 7-10. Stainless Steel Deflector	7-11
Figure 7-11. Bag Clamp Arm Bolts and Bearings.....	7-11
Figure 7-12. Bag Clamp Arm Bolts And Bearings Installed.....	7-12
Figure 7-13. Bag Clamp Pivot Block.....	7-14
Figure 7-14. Air Supply Fitting	7-15
Figure E-1. Standby Menu.....	E-1
Figure E-2. Configuration Menu.....	E-2
Figure E-3. Security Menu.....	E-2
Figure E-4. Standby Menu.....	E-3
Figure E-5. Seed Count Setpoint Menu	E-3
Figure E-6. Seed In Sample	E-3
Figure E-7. Wt. of Sample Menu.....	E-4
Figure E-8. Total Seed Ct. Menu	E-4
Figure E-9. Standby Menu.....	E-5
Figure E-10. Target Weight Menu.....	E-5

List of Tables

Table	Page
Table 3-1. TE100 Operational Controls.....	3-8
Table B-1. TE100 Spare Parts List	B-1
Table C-2. TE100 Mechanical Drawings	C-1
Table D-3. TE100 Electrical Drawings	D-1

This Page Intentionally Left Blank

Chapter 1

Product Description

1.1 General Description

This chapter will provide a high-level product description of the TE100.

1.2 Introduction

The Taylor Products TE100 is an electronic, self-correcting, small bagging scale. The TE100 electronic weighing and control package is one of the most advanced weighing systems available. Using a single load cell, the TE100 is a very economical and accurate scale.

The TE100 comes in a standard configuration, but also has several optional features that are available. The TE100 units come standard equipped to fill a standard open mouth bag. Depending on how it is equipped, the TE100 can handle weighments from 20 to 125 lbs. (9.07 kilograms to 56.70 kilograms).

1.3 Manual Scope

This manual will provide information on installation, operation, preventive maintenance, troubleshooting, and repair of the Model TE100.

The appendices will include safety information, spare parts list, and mechanical drawings.

1.4 Electrical Requirements

The TE100 is designed to operate on 115 VAC at 50 or 60 Hz.

1.5 Pneumatic Requirements

The TE100 uses approximately 2 CFM (57 liters) @ 75-80 PSI (.52-.55 MPa) of compressed air. Taylor Products recommends that the air supply line be equipped with a refrigerated air dryer, or at the very least a water separator.

1.6 Major Systems and Components

When working with the Model TE100, it is important to understand the major systems and components of the unit. The major components of the system are:

- Scale cabinet assembly
 - Cabinet
 - Shut off gate
 - Shut off gate bearings
 - Shut off gate cylinder
 - Dribble gate
 - Dribble gate cylinder
 - Dribble gate mounting straps
 - Load cell
 - Control box
 - MAC valves
 - Filter/Regulator/Lubricator (FRL) assembly
- Spout assembly
 - Spout
 - Bag clamp arms
 - Bag clamp pads
 - Start switch
 - Bag position switch

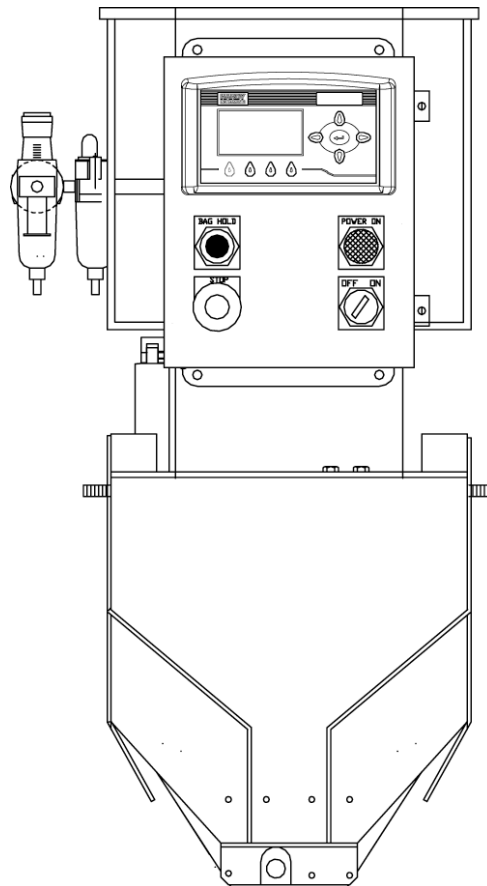

Note: Some machines may have the control box mounted off to one side.

Figure 1-1. TE100 Front View

1.6.1 Scale Cabinet Assembly

The scale cabinet assembly is the upper portion of the TE100. The scale cabinet assembly is made up of several components.

1.6.1.1 Scale Cabinet

The scale cabinet is the core of the TE100. All other TE100 components are mounted on the scale cabinet.

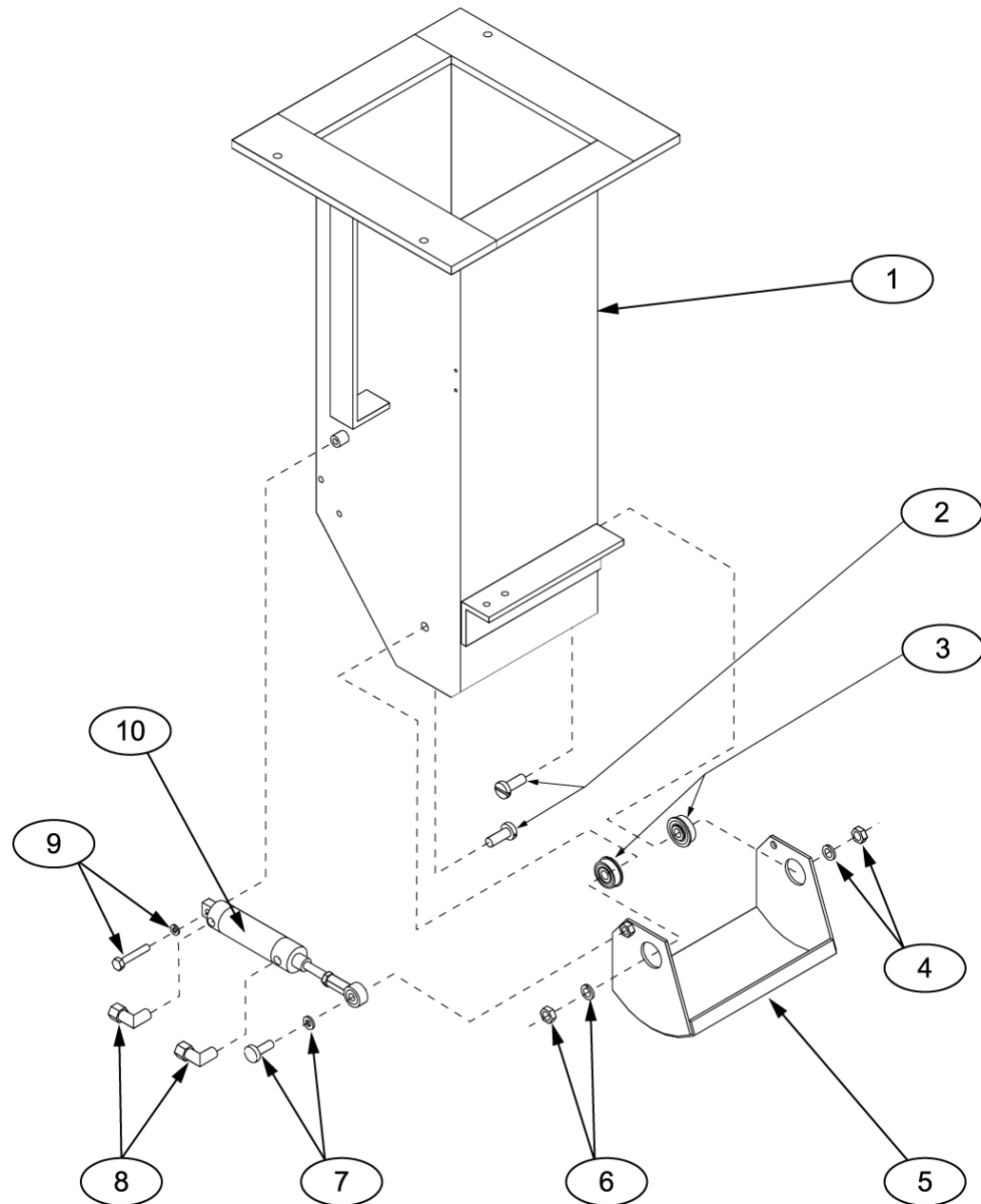

Item #	Description	Item #	Description
1	Scale cabinet	6	Lock washer and jam nut
2	Shut off gate pivot bolts	7	Cylinder to shut off gate bolt and washer
3	Shut off gate pivot bearings	8	Quick connect fittings
4	Lock washer and jam nut	9	Cylinder to cabinet bolt and washer
5	Shut off gate	10	Shut off gate cylinder

Figure 1-2. Scale Cabinet and Shut Off Gate

1.6.1.2 Shut Off Gate

The shut off gate is used to stop product flow into the package, after target weight has been achieved.

1.6.1.3 Shut Off Gate Bearings

The shut off gate rides on a pair of sealed bearings. The use of bearings ensures that the shut off gate is able to smoothly open and close.

1.6.1.4 Shut Off Gate Cylinder

The TE100 uses a pneumatic cylinder to open and close the shut off gate. The gate is mounted on the left side of the scale cabinet.

1.6.1.5 Dribble Gate

The TE100 is equipped with a sliding steel gate that is used to control the flow of product from the hopper. By using a dribble gate, the TE100 is capable of delivering product at two different feed rates. The result is a more efficient fill cycle. When the dribble gate is all the way open, the TE100 is filling at the bulk rate. When the dribble gate cylinder extends, it partially blocks the flow of product.

1.6.1.6 Dribble Gate Cylinder

The dribble gate is extended and retracted using a pneumatic cylinder that is mounted on the rear of the TE100. The rod end of the dribble gate cylinder is bolted directly to the dribble gate, while the cylinder end is bolted to the dribble gate cylinder mounting bracket.

1.6.1.7 Dribble Gate Mounting Rails

The TE100 is equipped with two aluminum rails on rear of the TE100. These rails provide the mounting point for the dribble gate cylinder mounting bracket.

1.6.1.8 Load Cell

The load cell is used to sense the weight of the material in the package. As material is loaded into the package, the load is applied to the load cell in a linear fashion. As the load increases, the voltage output from the load cell increases.



CAUTION

A sudden jerk or shock, such as being struck by a tool or hitting the spout, etc., can cause load cell damage. The load cell is NOT covered by warranty.

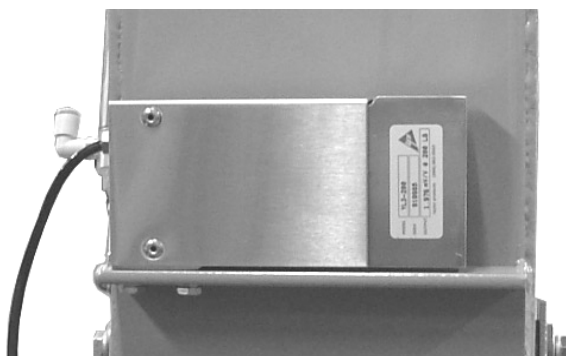

Figure 1-3. Load Cell

1.6.1.9 MAC Valves

There are several MAC valves that are mounted on the rear of the TE100. These valves are used to control various pneumatic components on the TE100, such as the dribble gate, shut off gate, and bag clamp arms.

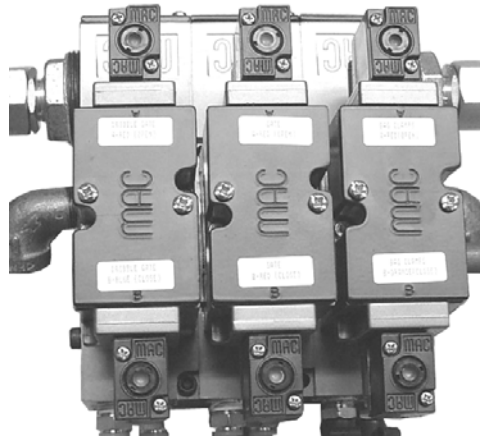

Figure 1-4. MAC Valves

Each of the MAC valves is equipped with a manual operation button, or test button. The operator can use a pencil or small screwdriver to press a button to test that valve function. The buttons are assigned as follows:

- Shutoff gate – Pressing the button marked CYL A will open the gate. Pressing the button marked CYL B will close the gate.
- Dribble gate – Pressing the button marked CYL A will retract the gate. Pressing the button marked CYL B will extend the gate.
- Bag clamp – Pressing the button marked CYL A will apply the bag clamp arms. Pressing the button marked CYL B will release the bag clamp arms.

Each of the MAC valves is also equipped with a flow control screw. These flow control screws control the actuation speed of the device that the valve is controlling. For example, if the flow control screw on the MAC valve that controls the shut off gate cylinder is turned counter-clockwise (opened), it will make the shut off gate open and close faster. If the flow control screw is turned clockwise (closed) it will make the shut off gate open and close slower.

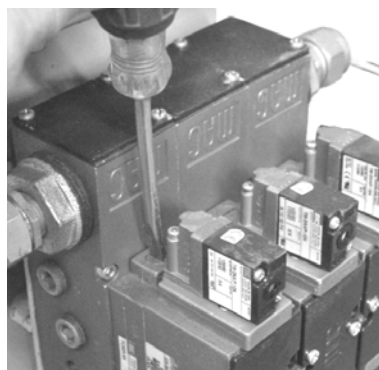

Figure 1-5. MAC Valve Flow Adjustment

1.6.1.10 Filter/Regulator/Lubricator (FRL) Assembly

The air pressure regulator used on the TE100 is a combination unit. It is a Filter/Regulator/Lubricator (FRL) assembly. This unit filters the incoming compressed air, regulates its pressure, and adds a lubricant to the air that provides lubrication to the internal components of the pneumatic devices that are downstream.

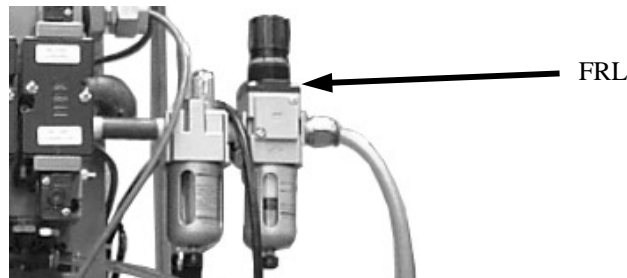
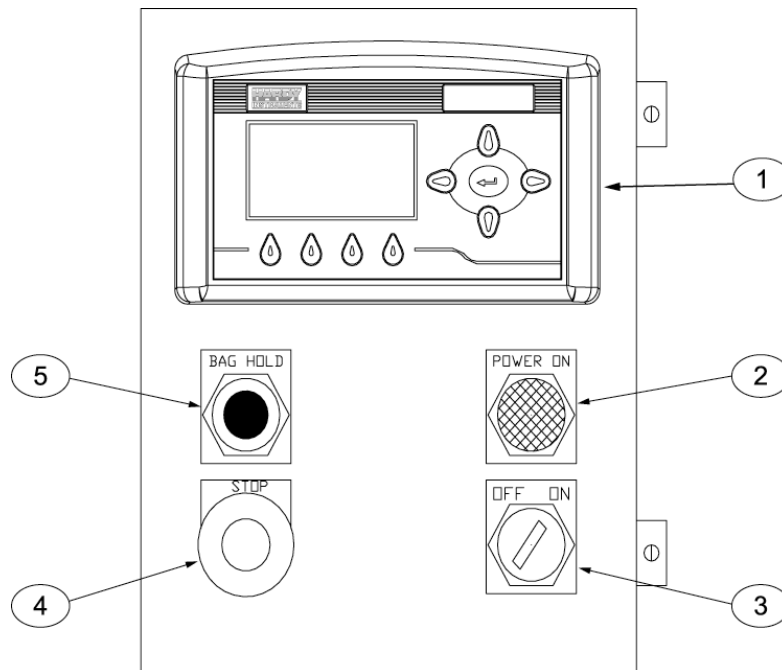

Figure 1-6. Filter/Regulator/Lubricator (FRL) Assembly

1.6.1.11 Control Box

The TE100 is equipped with a control box that contains the electrical controls. The main component of the control box is the T4000 control panel. This control panel is used to set the operating parameters for the unit and to monitor the operation of the machine. The POWER switch is located on the lower right corner of the control box. Above the POWER switch is the POWER ON indicator. This indicator will illuminate when the POWER switch is in the ON position. In the lower left corner of the control box is the STOP button/indicator. When the STOP button is pressed, the machine will immediately stop and the indicator will illuminate red. Directly above the STOP button is the BAG HOLD button. Pressing this button will prevent the TE100 from dropping the completed package so the final weight can be checked.



Item #	Description	Item #	Description
1	T4000 control panel	4	STOP button/indicator
2	POWER ON indicator	5	BAG HOLD button
3	POWER switch		

Figure 1-7. Control Panel

1.6.2 Spout assembly

The entire spout assembly is suspended from the load cell. The only place that the spout assembly should contact any component on the scale cabinet assembly is on the top of the load cell where it is bolted to the load cell.

1.6.2.1 Spout

The spout directs the product as it falls from the scale cabinet assembly into the package. The spout also serves as the mounting point for the bag clamp arms, the bag clamp cylinders, the start switch, and the bag position switch.

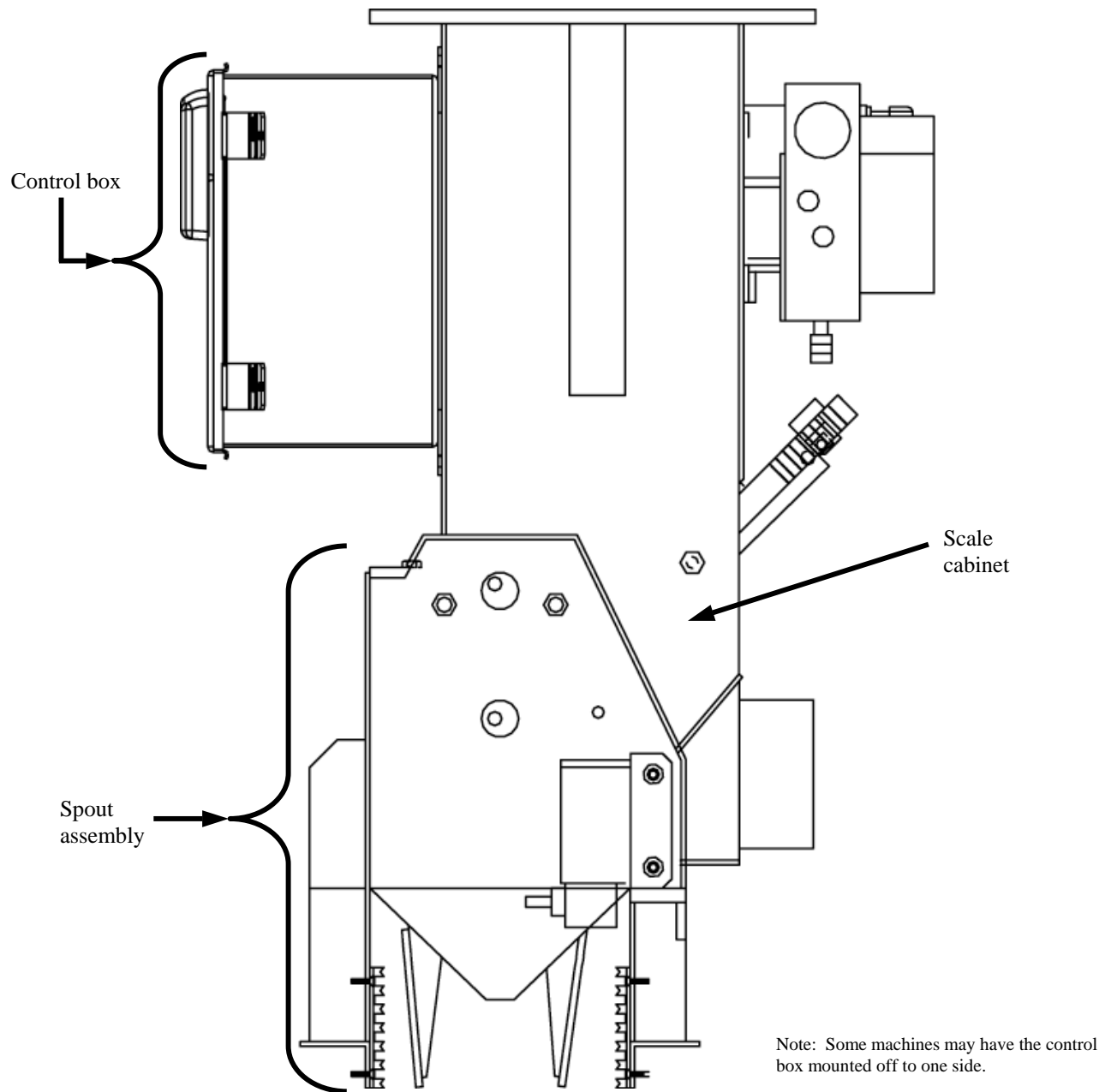

Figure 1-8. Spout Assembly – Side View

1.6.2.2 Bag Clamp Arms

The TE100 uses two bag clamp arms. Each bag clamp arm pivots on a set of sealed bearings. The bag clamp arms are linked together using two chain-type links and a pivot block on each end of the bag clamp arms.

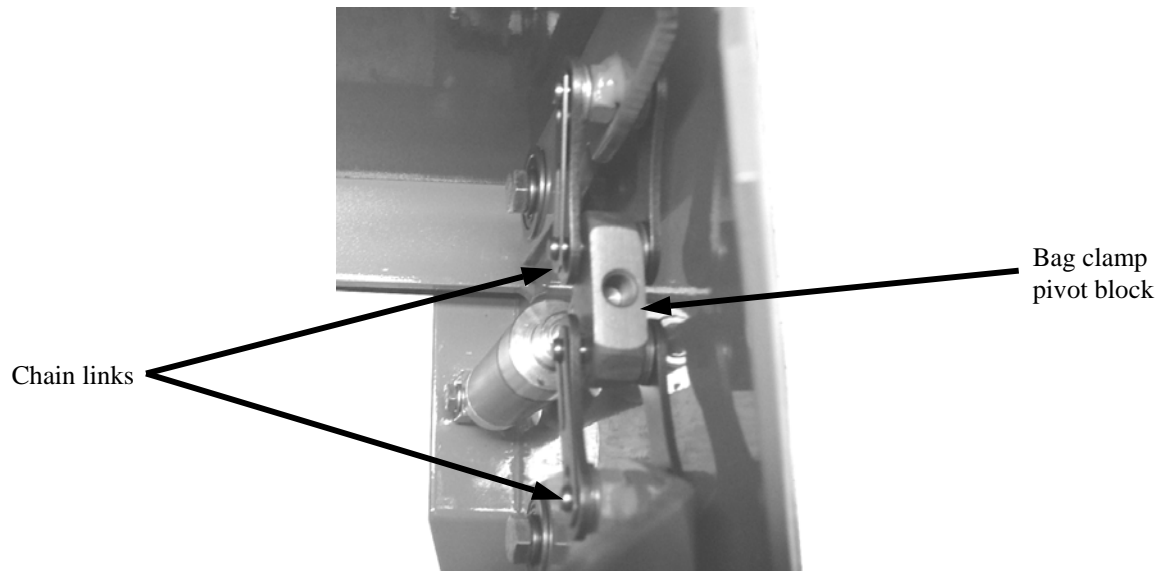

Figure 1-9. Chain Links and Pivot Block

The bag clamp arm that is located to the rear of the TE100 is equipped with a stainless steel deflector.

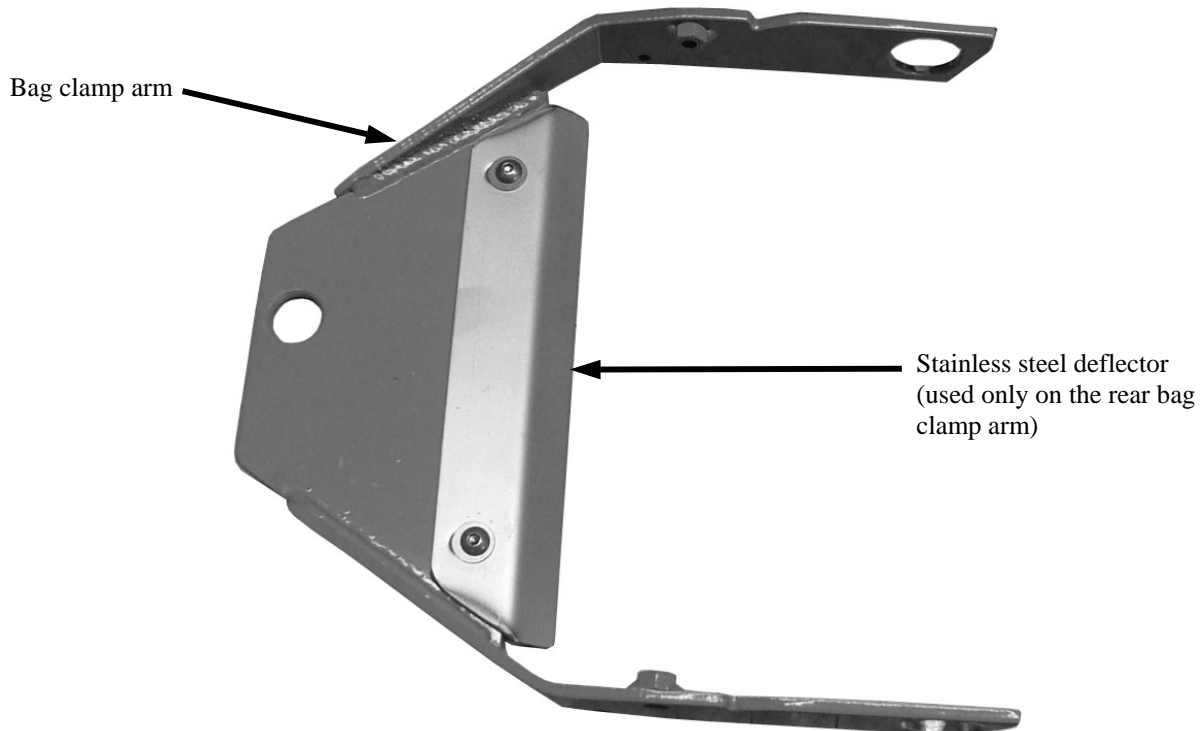

Figure 1-10. Bag Clamp Arm – Shown With Stainless Steel Deflector

1.6.2.3 Bag Clamp Cylinders

Two pneumatic cylinders are used to open and close the bag clamp arms. There is a bag clamp cylinder mounted on each side of the spout. Both cylinders are mounted inside the spout. The cylinder end of the bag clamp cylinder is mounted to the spout. The rod end of the cylinder is threaded into the pivot block that is connected to the bag clamp arms via chain links.

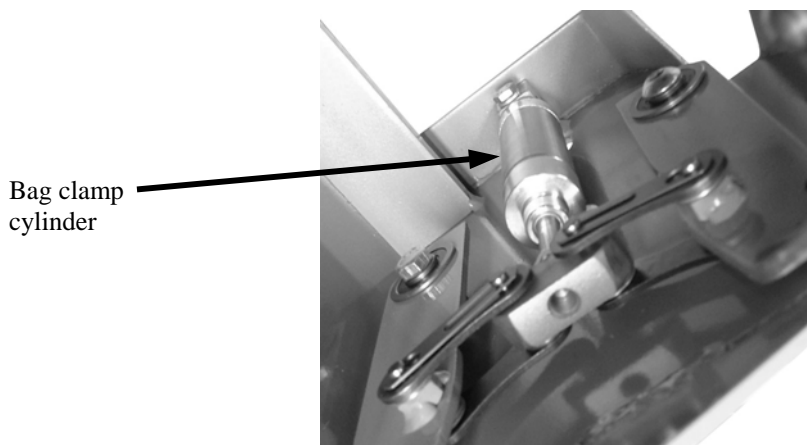

Figure 1-11. Bag Clamp Cylinder (1 of 2 Shown)

1.6.2.4 Bag Clamp Pads

The TE100 uses two ribbed, rubber pads to help hold the package on the TE100 spout as the package fills. The bag clamp pads are mounted on the spout and remain stationary. When the bag clamp arms are actuated, they press the sides of the bag against the bag clamp pads.

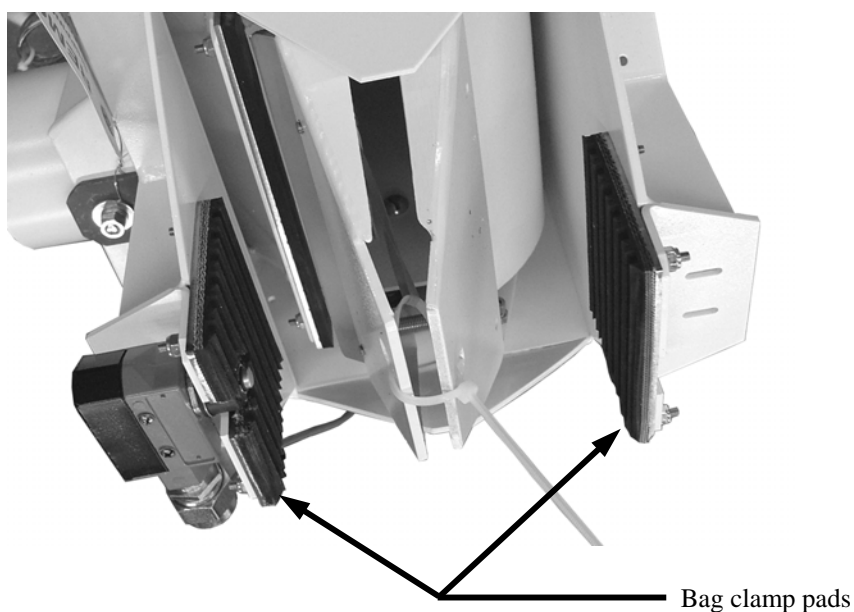

Figure 1-12. Bag Clamp Pads

1.6.2.5 Start Switch

The TE100 uses a rotary start switch. This switch is equipped with a wire bale. As the operator places the bag on the spout, their hand will trip the metal bale. As their hand touches the bale, the bale causes the shaft on the switch to rotate. This causes the internal contacts to make. This initiates the fill cycle.

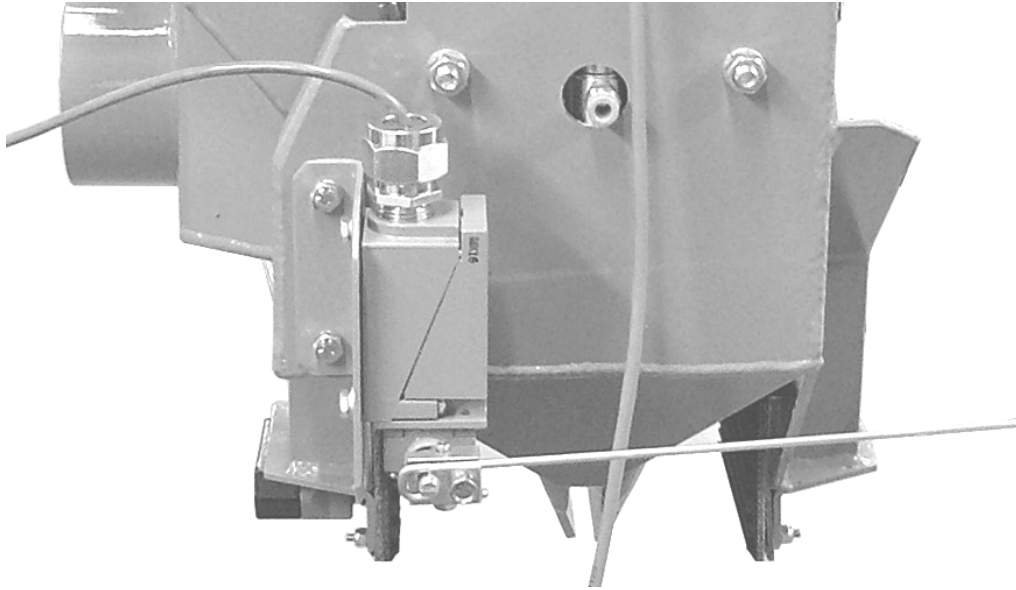

Figure 1-13. Start Switch

1.6.2.6 Bag Position Switch

The TE100 may be equipped with an optional bag position switch. The purpose of the switch is to prevent starting the fill cycle, in the event that the start switch is tripped when there is no bag in position to catch the product.

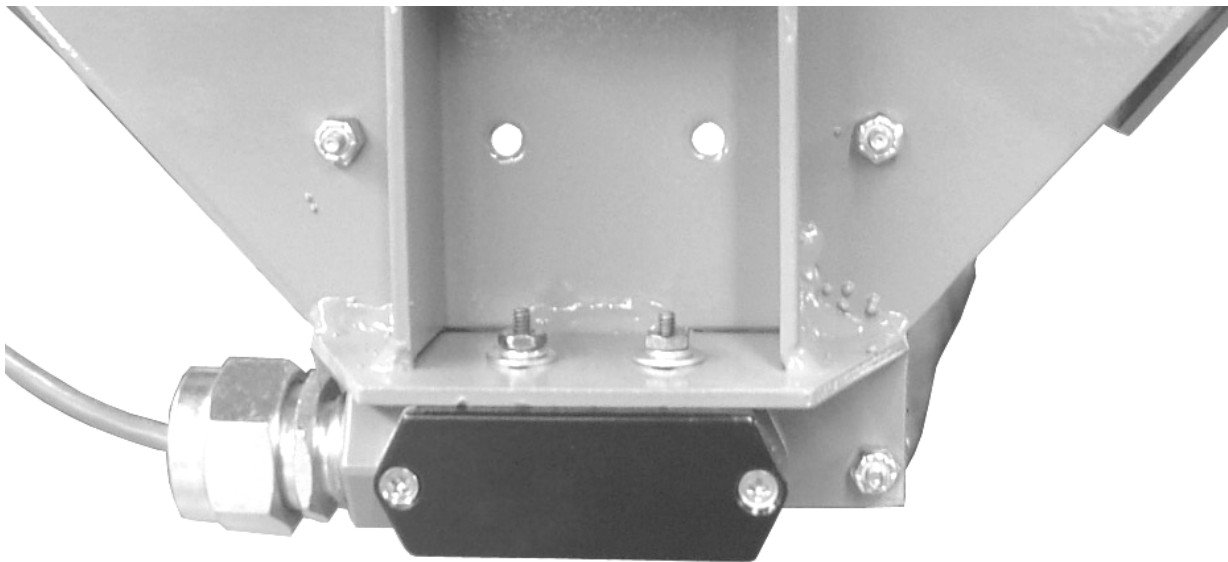

Figure 1-14. Bag Position Switch

1.6.2.7 Optional Small Bag Adapter

The TE100 can be equipped to fill bags that would normally be too small for the TE100. There are two small bag adapters that are available for the TE100, depending on the size of bag that is desired.

Depending on the density of the product, the round (actually oval shaped) small bag adapter is used to fill packages ranging from 5–10 lb (2.3–4.5 kg) in size, while the rectangular small bag adapter is used to fill packages ranging from 10–20 lb (4.5–9.0 kg) in size.

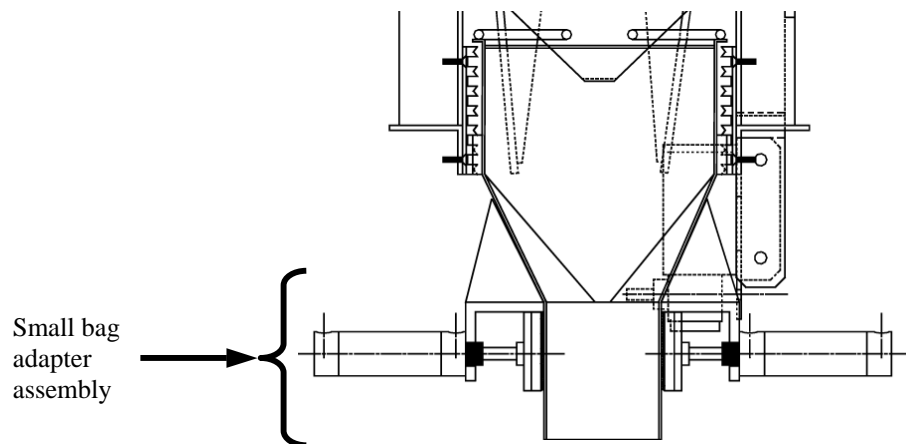

Figure 1-15. TE100 With Small Bag Adapter Installed

This Page Intentionally Left Blank

Chapter 2

Receiving Equipment

2.1 General Description

The TE100 and all of its components are thoroughly inspected before shipment. Upon receipt of the equipment, it is important that the machine be carefully inspected for shipping damage. In the event that damage is found, contact the shipping company and follow their process for reporting shipping damage.

2.2 Uncrating the Equipment

Follow the procedure below to unpack the equipment and prepare it for installation.

1. The TE100 hangs from a hopper. Make sure the hopper is in its final position and ready for the TE100 to be installed.
2. Before opening the box and removing TE100 from the shipping pallet, inspect the box, and pallet for visible damage.
3. Remove the box. Use care when unpacking the TE100 to avoid damaging the unit.



Figure 2-1. Typical Shipping Box (2 Boxes Shown)

4. Check the components for damaged or missing parts. If there is damage, notify the shipper and Taylor Products immediately. If the unit is not damaged, the TE100 is now ready for assembly. Refer to 3.2 Mechanical Setup.

This Page Intentionally Left Blank

Chapter 3 Setup/Installation

3.1 General Description

Only persons who have been properly trained and hold the appropriate qualifications should attempt to install, operate, or maintain this equipment.



WARNING

Before installing, adjusting, or servicing any electrical component, be sure to become familiar with the electrical schematic for the machine.



WARNING

Before installing, adjusting, or servicing any pneumatic component, be sure to become familiar with the pneumatic schematic for the machine.

When mounting the TE100, it should be mounted on a hopper that has 60° sides. The use of a shut off gate is acceptable.



CAUTION

Never install the TE100 on a downspout. This will result in the scale not functioning.

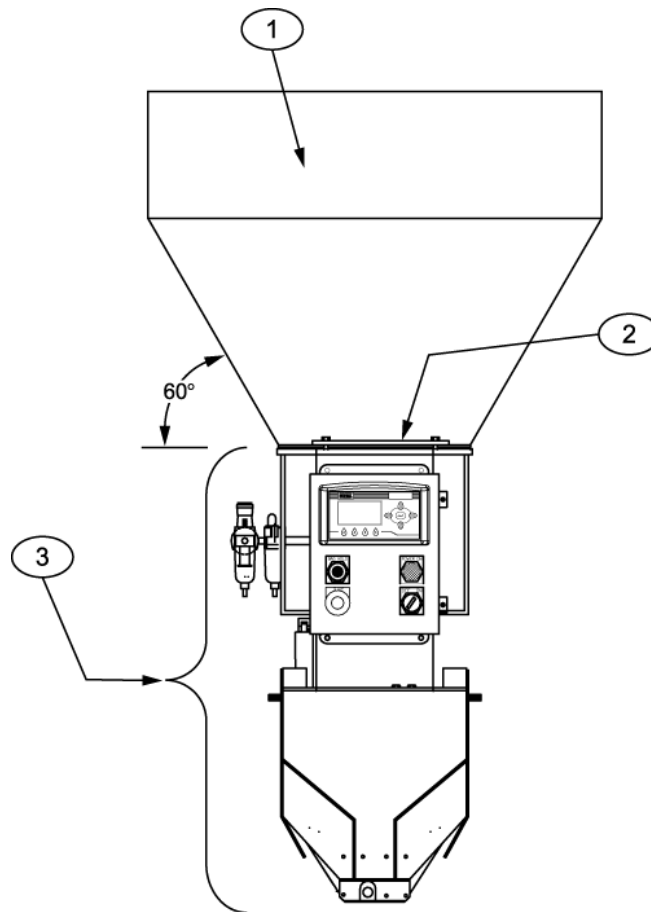

Item #	Description	Item #	Description
1	Hopper (customer supplied)	3	TE100
2	Mounting bracket (1 of 2 shown)		

Figure 3-1. Mounting the TE100

3.2 Mechanical Setup

Once the TE100 has been moved into the position where it will operate, follow the steps below to setup the mechanical components for operation.

1. Lift the scale cabinet assembly by its bottom edge and slide the scale cabinet onto the mounting flange. This may require two people.

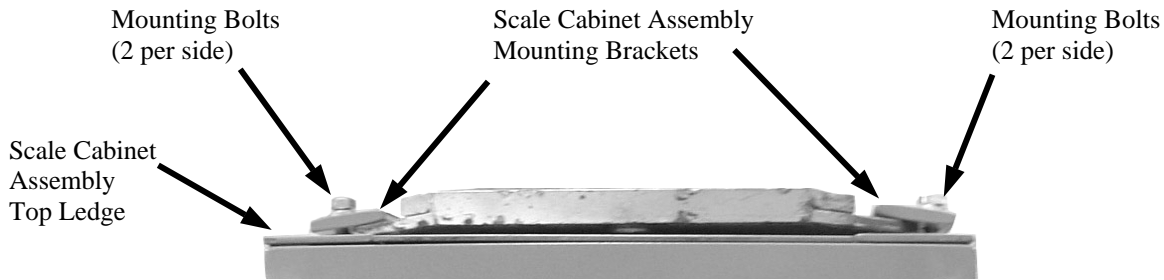

Figure 3-2. Hanging the Cabinet Assembly on the Hopper Flange

2. With the mounting clamps over the flange, center the cabinet under the bin or transition.
3. Tighten the mounting bolts.
4. Use a torpedo level on the top ledge of the cabinet assembly. The cabinet assembly must be level. Adjust the mounting bolts as needed to get the cabinet assembly level.
5. Remove the shipping bracket.

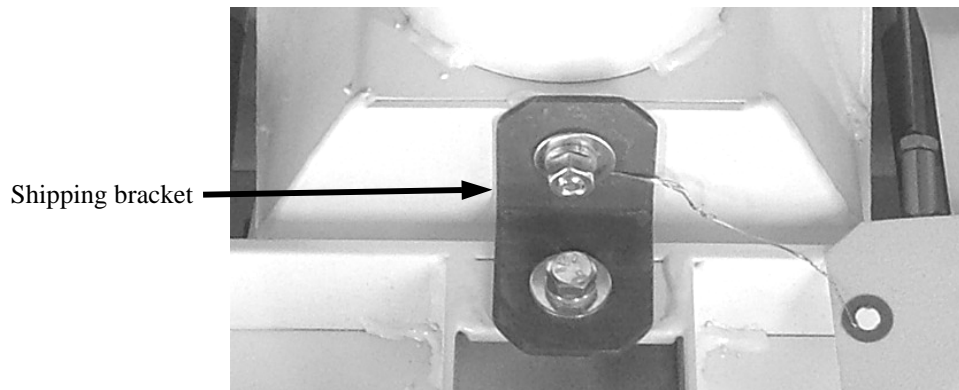

Figure 3-3. Shipping Bracket Location

6. Connect the main electrical and pneumatic connections.
7. Set the air pressure regulator. Refer to 3.4 Making Pneumatic Connections.
8. Dry cycle the TE100. Refer to 3.5 Dry Cycle.
9. Calibrate the TE100. Refer to 3.6 Calibration.

3.3 Making Electrical Connections

Before connecting the TE100 to the electrical supply, it is vital that the unit be properly grounded. The recommended method is to plug the power cord into an earth grounded receptacle. The TE100 requires 115 VAC at 50 or 60 Hz to operate. The TE100 should be placed within 6 feet of the electrical outlets that it will be connected to.

3.3.1 Electrical Connections

The following schematic illustrates how the different electrical components fit into the overall electrical layout of the machine. If any electrical components have to be removed or replaced, use these schematics to correctly install the valves.

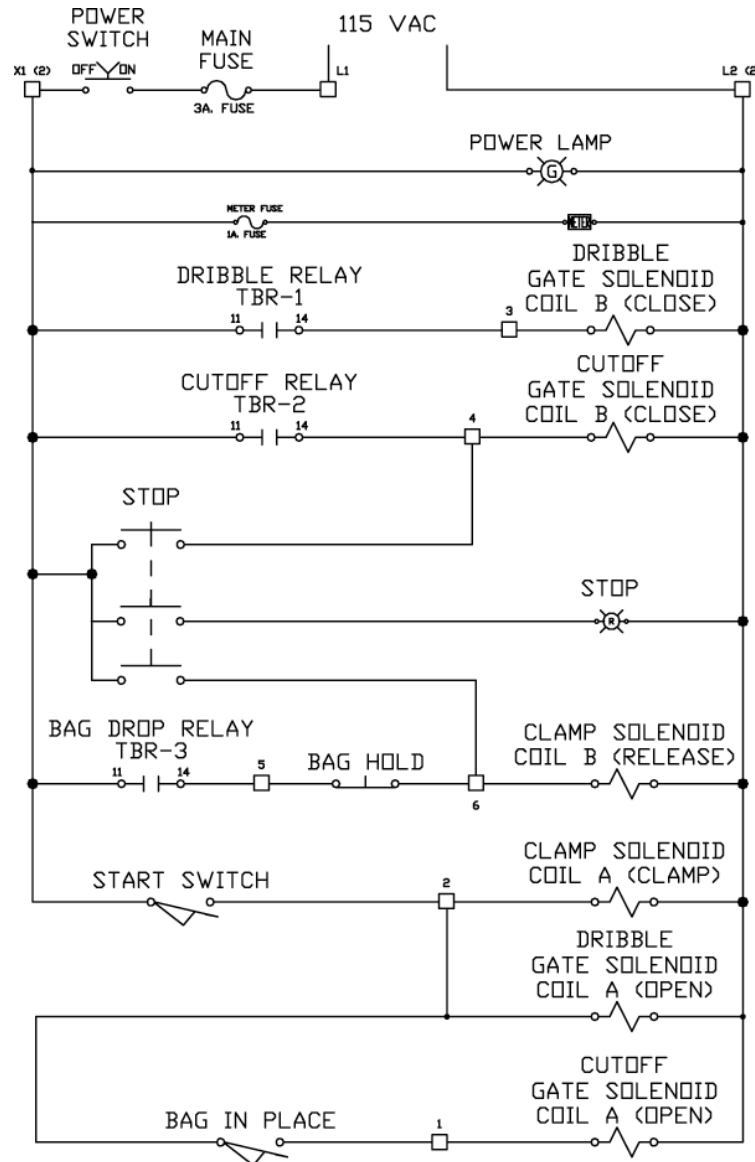
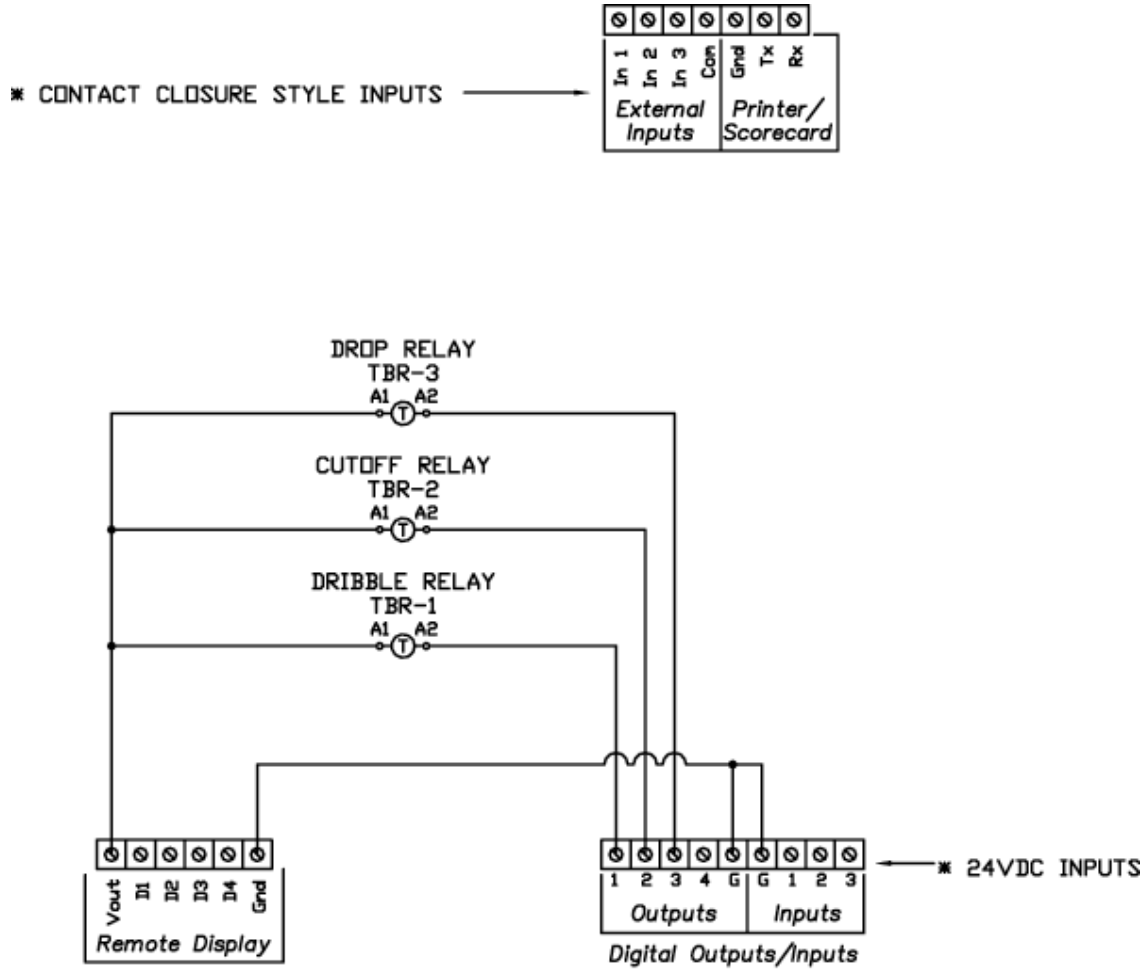

Figure 3-4. MAC Valve Connections and Schematic



* NOTE:
 CONTACT CLOSURE AND VOLTAGE INPUTS WORK THE SAME
 INPUT 1 - ZERO INPUT
 INPUT 2 - HOLD HIGH INPUT
 INPUT 3 - NOT USED

OUTPUT 1 - SP1
 OUTPUT 2 - SP2
 OUTPUT 3 - SP3
 OUTPUT 4 - START

Figure 3-5. Connection Diagram

Wiring Diagram

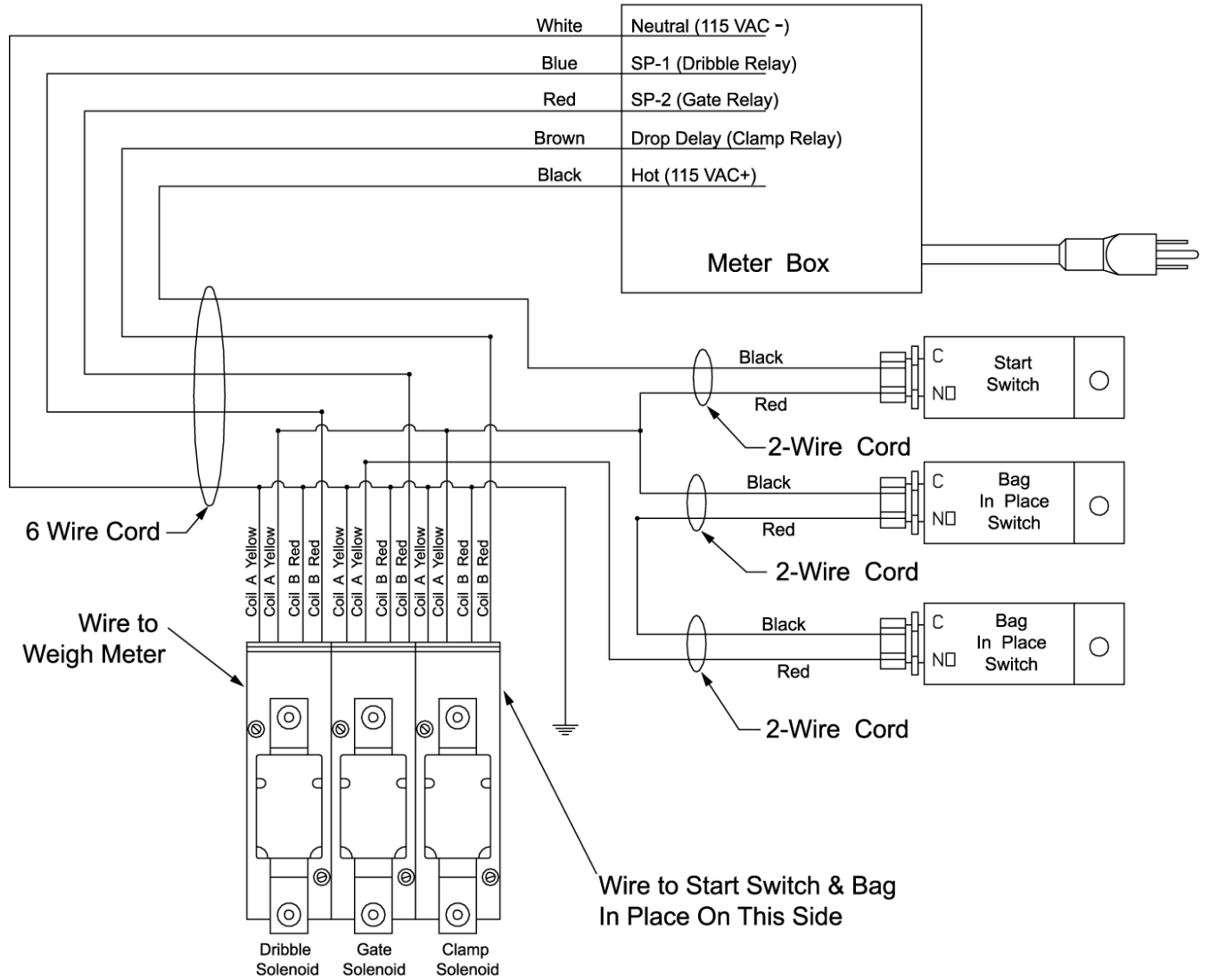

Figure 3-6. Wiring Diagram

3.3.2 Load Cell Connections

The cable from the load cell is connected to the rear of the electrical enclosure board inside the control panel. Use the graphic below to correctly connect the load cell to the control panel.

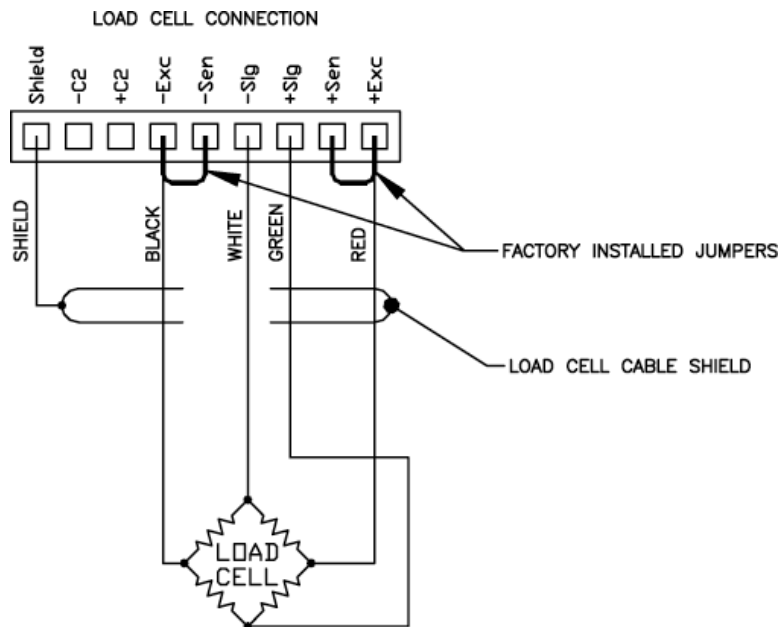

Figure 3-7. Load Cell Connections

3.4 Making Pneumatic Connections

The TE100 requires a compressed air supply line that is capable of delivering approximately 2 CFM (57 liters) @ 75-80 PSI (.52-.55 MPa) of compressed air. Taylor Products recommends that the air supply line be equipped with a refrigerated air dryer, or at the very least a water separator. After making pneumatic connections, check all connectors for leaks using a soapy water mixture. Bubbles will appear at the site of any leaks. Eliminating or reducing air leaks will reduce wear on the air supply equipment.

3.4.1 Lubrication Requirements

The pneumatic cylinders require lubrication to ensure their proper operation and to extend their useful life. The lubricator should be filled with 10 or 20 weight, non-detergent oil.

The oil flow control knob, located on top of the lubricator, should be set so that the lubricator is delivering 1 drop of oil for every 15 to 20 bags that are filled.

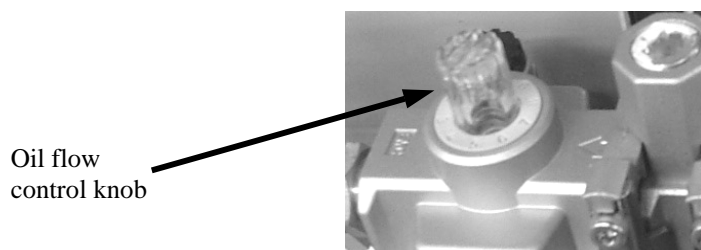

Figure 3-8. Lubricator – Oil Flow Control Knob

Use caution when setting the flow control on top of the lubricator. While too little oil can cause operational problems, so can too much oil. If the oil control is set too high, it may result in the solenoid valves, cylinders, and air supply lines becoming fouled.

3.5 Dry Cycle

Once all electrical/pneumatic connections have been made, the operator should dry cycle the machine to test the control components. If all components operate properly, the machine is ready to calibrate.

Note: The cylinders may be cycled manually by pressing the test buttons on the solenoid valves.

1. Make sure the power connection has been connected to the power source.
2. Turn the power switch on the control panel of the TE100 to the ON position.
3. Make sure that the air pressure on the FRL is set to specification.
4. If equipped with a bag position switch, place a bag, or piece of a bag, over the bag position switch.
5. Trip the bale on the START switch. This should result in the following actions:
 - The bag clamp cylinders will extend and pushing the bag clamp arms out against the bag clamp pads.
 - The shut off gate cylinder will extend to open the shut off gate and simulate the start of the fill cycle.
6. Press the STOP button to simulate the package reaching target weight. This should result in the following actions:
 - The shut off gate cylinder will retract to close the shut off gate.
 - The bag clamp cylinders will retract, pulling the bag clamp arms inward, thus releasing the bag.
7. Test the dribble gate function by pressing the test buttons on MAC valve that controls it.

3.6 Calibration

The TE100 is calibrated before it is shipped from the factory. However, the TE100 requires a thorough inspection and calibration, prior to being put into service. The TE100 should be calibrated on a weekly basis during the first month of operation. After the first month of operation has been completed, calibration of the TE100 should be done on a monthly basis. The TE100 will also require calibration anytime the full-scale weight range is changed. When calibrating the TE100, always use a certified test weight.

Prior to starting the calibration process, the operator should familiarize themselves with the controls on the outside and inside of the control panel. The TE100 can be calibrated to weigh packages in pounds or kilograms. The procedures in this chapter are written for weighing in pounds. To set up a machine for metric weighments, simply substitute a metric certified test weight in place of the standard test weight referenced in the calibration procedures, and set the T4000 to weigh in the desired units.

***Important:** Only authorized personnel may perform calibration procedures. To ensure this, the T4000 controller utilizes security control. A four-digit password is required to access the calibration controls. The password is set at the factory to 2205. The manager may reset this password to a four-digit sequence of their choice, at their discretion.*

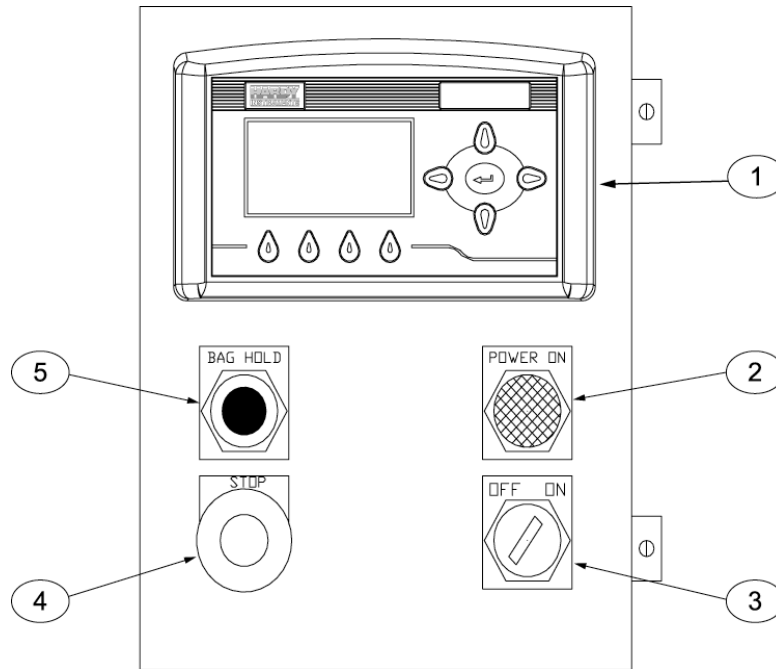

Item #	Description	Item #	Description
1	T4000 control panel	4	STOP button/indicator
2	POWER ON indicator	5	BAG HOLD button
3	POWER switch		

Figure 3-9. Control Panel

Table 3-1. TE100 Operational Controls

Control Device	Function
T4000 control panel	The T4000 is the master controller of the machine. The operator uses the T4000 to setup the machine to fill a specific product, and to monitor the fill cycle.
OFF / ON switch	Located on the lower right corner of the control panel. This switch is used to turn the electrical power to the TE100 ON or OFF.
POWER ON indicator	When the OFF / ON switch is turned on, this indicator will illuminate green to indicate that the machine is on.
STOP button/indicator	Located in the lower center of the control panel. This button is used to stop the TE100 in the event of an operational problem.
BAG HOLD button	When the BAG HOLD button is pressed and held toward the end of the fill cycle, it will prevent the controller from releasing the bag clamps. This forces the machine to hold the bag for a longer period of time, which will allow the operator to check the actual package weight so they can compare it to the desired package weight.

3.6.1 Pre-Calibration Mechanical Checks

1. Check to determine that the load cell has been installed properly.
2. Check for binding on the load cell or other parts of the system.



CAUTION

Binding on a load cell does not allow the load cell free vertical movement and may prevent the instrument from returning to the original zero reference point.

- a. The load cell must be mounted so that 100% of the load (vessel + contents) is applied vertically to the load cell.

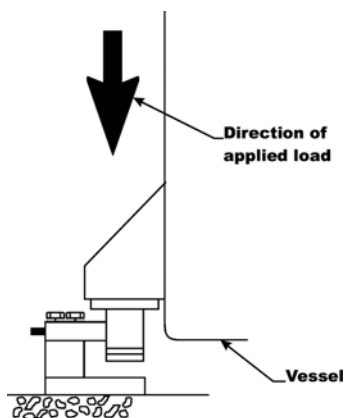

Figure 3-10. Load Passing Through Load Cell

- b. Do a visual check to see that nothing is binding the load cell or other parts of the weighing system. Make sure that nothing is draped over the spout or the load cell, such as a hose, electrical cord, tubes, or other objects.
3. Check to see that nothing comes in contact with the scale/vessel other than service wires and piping that have been properly mounted with flexible connectors.
4. Check to see that there is power to the T4000.
 - a. If there is power to the controller the front panel display should be illuminated.
 - b. If the display appears and a weight value is being displayed, the unit is ready for calibration.
5. Allow the instrument to warm up for about 15 minutes before doing the calibration procedures.
6. Put a load (weight) on the scale or vessel. For a full load test, the operator can put 80 – 100% of the expected weight for their process on the scale.
7. Check to see if the weight reading changes on the display in the proper direction.
 - a. For example, if the display reads 100 lbs and a 20 lb load is placed on the vessel or scale, the display should read 120 or some value over 100.
 - b. If the display reads 80 lbs and a 20 lb load is placed on the vessel or scaled, the reading is going in the wrong direction and indicates some problem with the system.
 - c. If the display is reading improperly or shows no change there is something wrong with the configuration or the load cells.
8. If the display changes in the proper direction, remove the weight and proceed to calibrate the Weigh Controller.

Note: When calibrating the T4000 for the first time, go from one sub-menu to the next in sequence.

Note: The settings provide below are just an example. The actual settings used will vary based on the specific application.

3.6.2 Calibrating the T4000 Control Panel

The following steps are used to perform the calibration.

1. Make sure the T4000 has been configured for the intended application. This includes setting the units, decimal point, scale capacity, averages, etc.
2. From the Summary display press the function key under the word MENUS. The Configuration menu appears.
3. Press the down arrow button until the cursor is in front of Calibration.

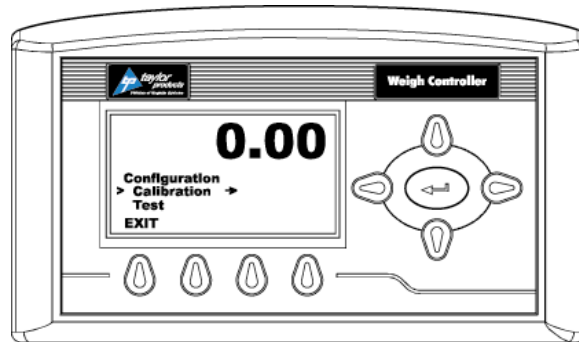

Figure 3-11. Placing the Cursor In Front Of Calibration

4. Press the enter button. The Calibration menu appears.
5. Press the down arrow button until the cursor is in front of “Trad Cal”. Traditional Calibration is the method of calibration that uses test weights. Taylor Products recommends that the test weights total 80 – 100% of the desired package weight, and that the weight be distributed uniformly on/in the scale.

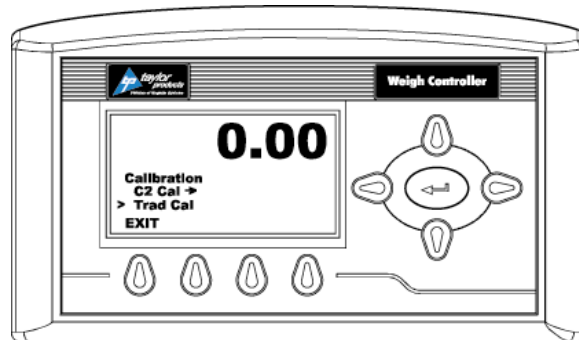

Figure 3-12. Placing The Cursor In Front Of Trad Cal

6. Press the enter button. The Trad Cal menu appears.

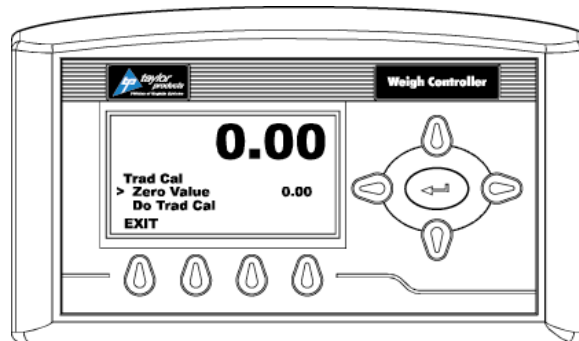

Figure 3-13. Placing The Cursor In Front Of Zero Value

7. Press the enter button. The Zero Value weight menu appears.
8. Traditional Calibration requires a zero point and the physical placement of test weights on the scale. To set the Zero Value Weight:
 - a. Remove all weight “live load” from the Scale. The Zero Value should be 0.0.



CAUTION The scale MUST be empty.

- b. Wait 12 seconds or more.
9. Use the left and right arrow buttons to position the cursor. Use the up or down arrow buttons to enter the Zero Value for this instrument.

Note: Most applications will set the Zero Value to 0.00.

10. Press the enter button to save the entry.
11. Press the down arrow button until the cursor is in front of “Do Trad Cal ” (Zero)”.
12. Press the enter button to Do Trad Cal (Zero).
 - a. If prompted, enter the password. Once accepted, press enter again to Do Trad Cal (Zero).

Important: Only authorized personnel may perform calibration procedures. To ensure this, the T4000 controller utilizes security control. A four-digit password is required to access the calibration controls. The password is set at the factory to 2205. The manager may reset this password to a four-digit sequence of their choice, at their discretion.

- b. A “Cal Completed OK” message appears briefly if the calibration was successful.
 - c. An Error number appears if the calibration was not successful. An Error list is provided with the troubleshooting information later in this guide. Refer to this list in order to correct the error.
13. Press the down arrow button until the cursor is in front of Span Value.
14. Press the enter button. The Span Weight menu appears. The last Span Weight is displayed.

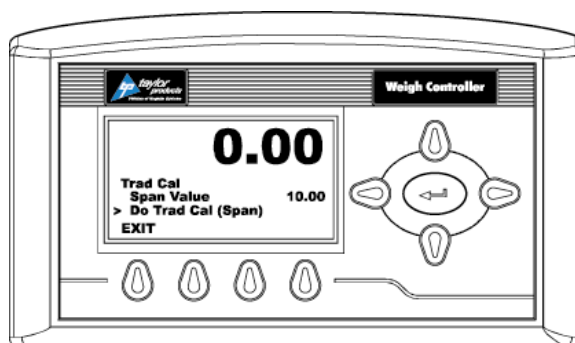

Figure 3-14. Span Value Displayed

15. To set the Span Weight:
 - a. Place a certified test weight on the scale.
 - b. Use the left and right arrows to position the cursor and the up or down arrows to enter the value of the test weight. If a 10 lb. weight is used, enter 10.00.
 - c. Press the enter button to save the entry.
16. Press the down arrow button until the cursor is in front of “Do Trad Cal (Span)”.

Setup/Installation

17. Press the enter button to Do the Trad Cal (Span).
 - a. A “Cal Completed OK” message appears briefly if the calibration was successful.
 - b. An Error number appears if the calibration was not successful. An Error list is provided with the Troubleshooting information later in this guide. Refer to this list in order to correct the error.
18. The scale is now calibrated.

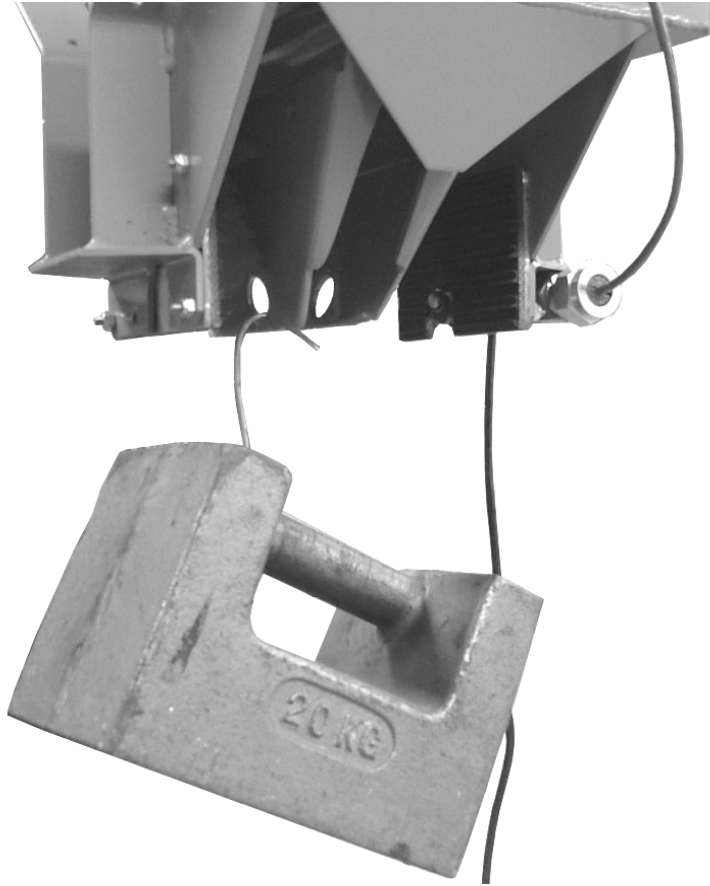

Figure 3-15. Hanging A Certified Test Weight On The TE100

3.6.3 Dribble Gate Setup

After completing the other calibration procedures, the operator should check the operation of the machine to determine if the dribble gate requires any adjustment. For example, when filling a 50 lb package in less than 4 seconds, if the package weights are erratic, move the dribble gate in one step. The result will be a slower fill rate and more stable bag weights.

1. Turn the TE100 off.
2. Disconnect the main electrical and pneumatic connections.
3. Loosen and remove the two bolts that secure the dribble gate cylinder mounting bracket to the dribble gate rails.

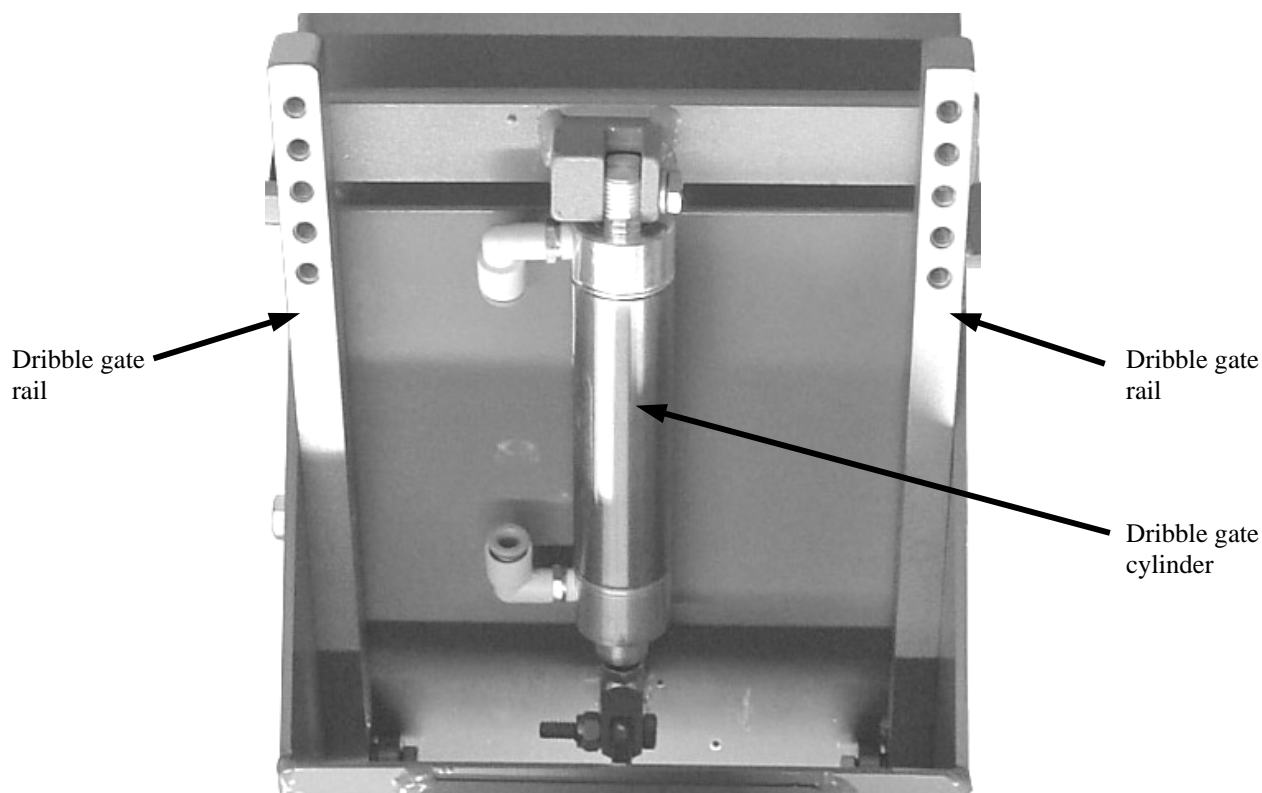

Figure 3-16. Dribble Gate Cylinder Mounting

4. Move the dribble gate cylinder mounting bracket inward to reduce the feed rate or outward to increase the feed rate.
5. Install and tighten the two bolts that secure the dribble gate cylinder mounting bracket to the dribble gate rails.
6. Connect the main electrical and pneumatic connections.
7. Turn the TE100 on and test for proper operation.

3.6.4 Setting Auto Adjust Cutoff

The TE100 control system utilizes an automatic correction feature. At the beginning of each production run, if a bag is either over or under the target weight, the TE100 will adjust the cutoff to correct for the overage/underage. This feature is called the Auto Adjust Cutoff, and is part of the Target Min./Max. submenu. The Auto Adjust Cutoff feature makes incremental adjustments over each fill cycle, until the final package weight matches the target weight.

3.6.4.1 Turning Auto Adjust Cutoff On/Off

For the function to work, the operator must first turn the feature on.

1. Make sure that the TE100 is turned on and warmed up.
2. From the Standby menu, press the function key below MENUS.
3. Use the arrow keys to scroll down to the Auto-Adj. Cutoff line.
4. Use the left/right arrow keys to toggle the Auto-Adj. Cutoff feature ON/OFF.
5. Press the enter key to save the setting. An “Entry Accepted” message should flash briefly.
6. Press the function key below EXIT on the menu.

3.6.4.2 Setting the Auto Adjust Limit

Changing this setting will change the number of bags required to reach the target weight at the beginning of each run.

1. Make sure that the TE100 is turned on and warmed up.
2. From the Standby menu, press the function key below MENUS.
3. Use the arrow keys to scroll down to the Auto-Adj. Limit line.
4. Press the enter key to access the set Auto-Adj. Limit screen.
5. Use the arrow keys to set the desired increment.
6. Press the enter key to save the setting. An “Entry Accepted” message should flash briefly.
7. Press the function key below EXIT on the menu, twice to get back to the Standby screen.

3.7 Installing the Optional Small Bag Adapter

The TE100 can be equipped to fill bags that would normally be too small for the TE100. There are two small bag adapters that are available for the TE100, depending on the size of bag that is desired.

Depending on the density of the product, the round (actually oval shaped) small bag adapter is used to fill packages ranging from 5–10 lb (2.3–4.5 kg) in size, while the rectangular small bag adapter is used to fill packages ranging from 10–20 lb (4.5–9.0 kg) in size.

1. Shut the TE100 off.
2. Disconnect the main electrical and pneumatic connections.
3. Remove the ¼-inch NPT coupling between the solenoid block and lubricator.
4. Replace the ¼-inch NPT tee with a flow control valve. Make sure the flow control valve is fully closed.
5. Disconnect the two blue hoses located at the top of each bag clamp cylinder and replace them with blue hoses connected to the tee that was just installed.
6. Connect the blue hoses removed from the bag clamp cylinder to the blue hoses on the small bag adapter cylinders.
7. Remove the red hoses from the bag clamp cylinders and connect them to the red hoses on the small bag adapter cylinders.
8. Relocate the start switch using the bracket provided with the small bag adapter.
9. Reconnect the air pressure to the regulator.
10. Grab the small bag adapter by the rod ears on each side and slide it up between the bag clamp arms and the bag clamp pads.
11. Turn the flow control valve on the newly installed tee to the full open position. This will clamp the small bag adapter in place.
12. Using the Manual Zero feature, zero the weight display.
13. Set the target weight and dribble weight.
14. Place a bag over the spout and trip the start switch to begin the fill cycle.

This Page Intentionally Left Blank

Chapter 4 Operation

4.1 General Description

This chapter will provide detailed descriptions of the operational controls of the TE100.

4.2 Operational Controls

The standard TE100 is a gravity fed packaging machine. The TE100 uses electronic controls and an electronic weighing system.

The TE100 control panel is equipped with several control knobs/switches that are used to setup and operate the unit.

- T4000 – The T4000 is the master controller of the machine. The operator uses the T4000 to setup the machine to fill a specific product, and to monitor the fill cycle.
- OFF / ON switch – Controls the flow of power to the control panel.
- STOP button/indicator – Located in the center of the control panel, when this button is pushed it will immediately interrupt the operation of the machine.
- BAG HOLD switch – The operator can push the button to the HOLD BAG position to delay releasing a filled bag. This is done so the operator can check the actual package weight to make sure that it matches the target weight.

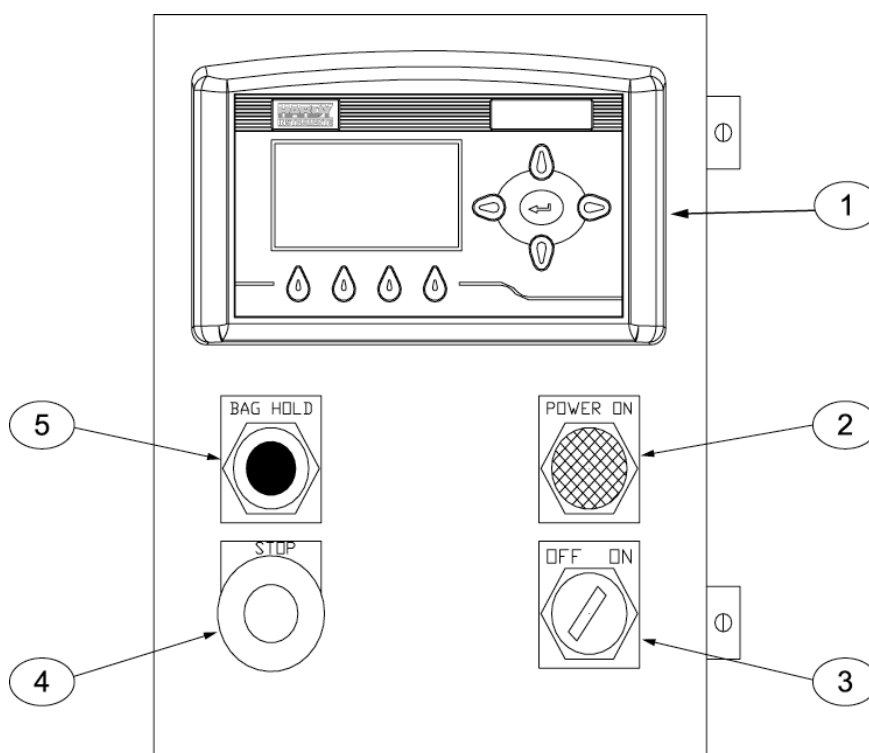

Item #	Description	Item #	Description
1	T4000 control panel	4	STOP button/indicator
2	POWER ON indicator	5	BAG HOLD button
3	POWER switch		

Figure 4-1. Control Box

4.2.1 T4000 Control Panel Features

The T4000 series weigh controller is used to program and monitor TE100. The control panel has a LCD screen, directional arrows, an enter button, and four function keys.

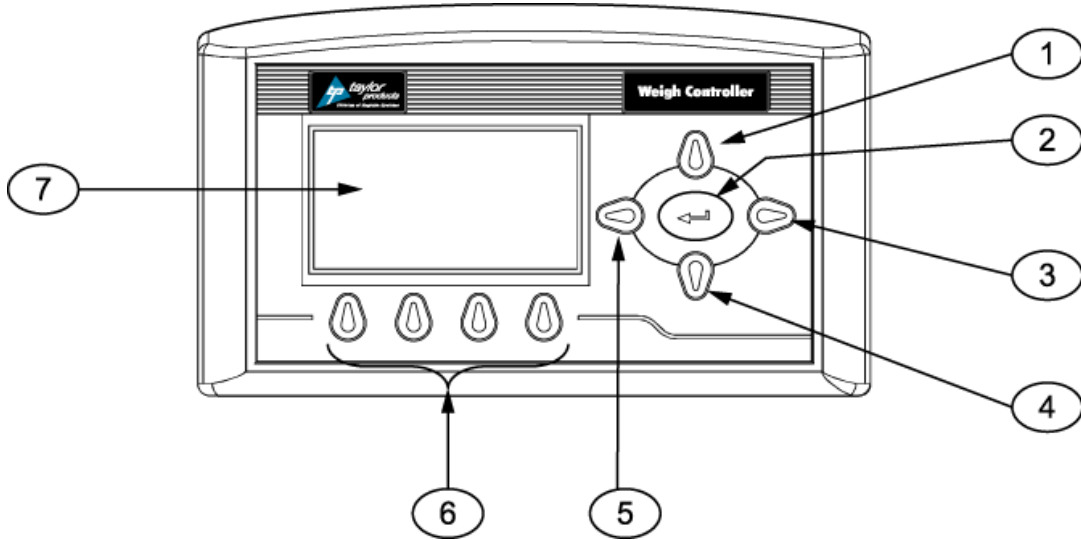

Item #	Description	Item #	Description
1	Up arrow button	5	Left arrow button
2	Enter button	6	Function buttons
3	Right arrow button	7	LCD panel
4	Down arrow button		

Figure 4-2. T4000 Control Panel

4.2.1.1 Entering Numbers Using The Control Panel

Prior to using the control panel, it is important to understand the process for entering a number into a field. When accessing a numbered field, the cursor will be placed in the default position, which is under the digit to the far right. To position the cursor at the desired position, use the left or right arrow keys to move the cursor. Once the cursor is placed in the desired position, use the up arrow key to increase the number, or use the down arrow key to decrease the number. Each press of the key will result in a change increment of one digit. For example, if 0 is displayed, pressing the up arrow key once will change the number to 1. After the desired number has been entered, press the enter key to save the entry.

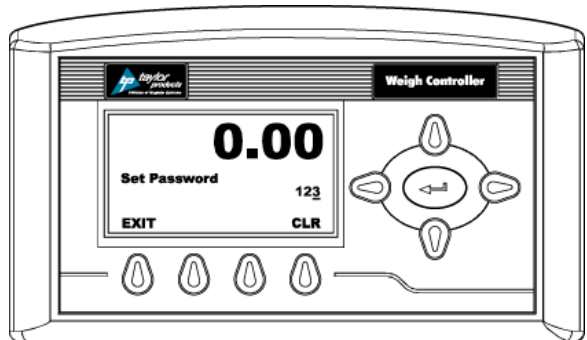

Figure 4-3. Cursor Positioned Below Digit On Right

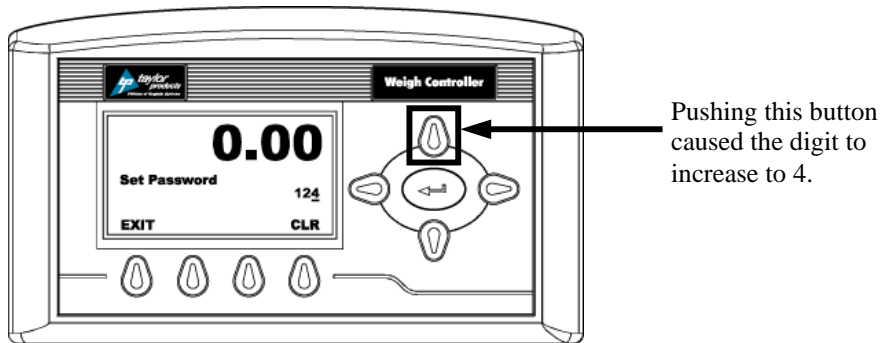

Figure 4-4. Operator Has Pressed The Up Arrow Causing Digit On Right To Increase To 4

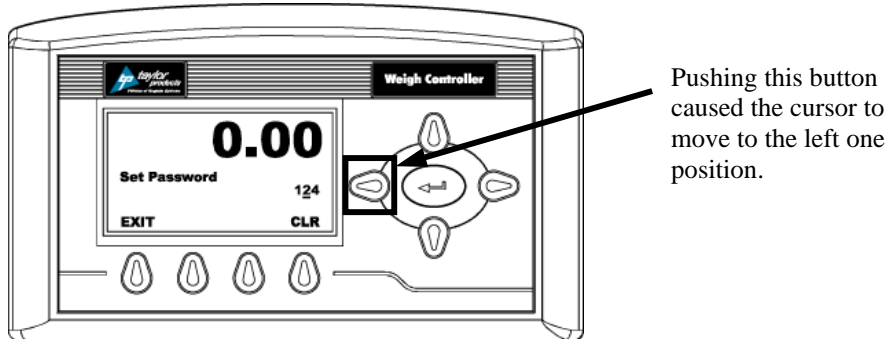

Figure 4-5. Operator Has Pressed The Left Arrow Moving Cursor Over 1 Position

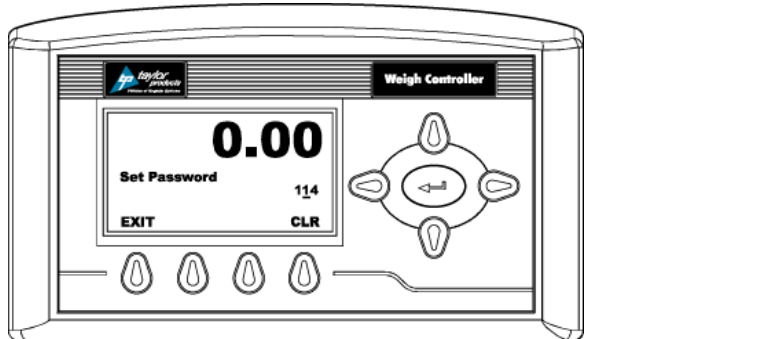

Figure 4-6. Operator Has Pressed The Down Arrow Causing Center Digit Decrease To 1

4.2.2 T4000 Menu System

The T4000 menu system allows for easy navigation. From the Standby screen, when the function key that is below MENUS is pressed, the Configuration Menu will appear. This menu is where the operator must go to access all of the submenus. The block diagram that follows illustrates the menu layout for the system.

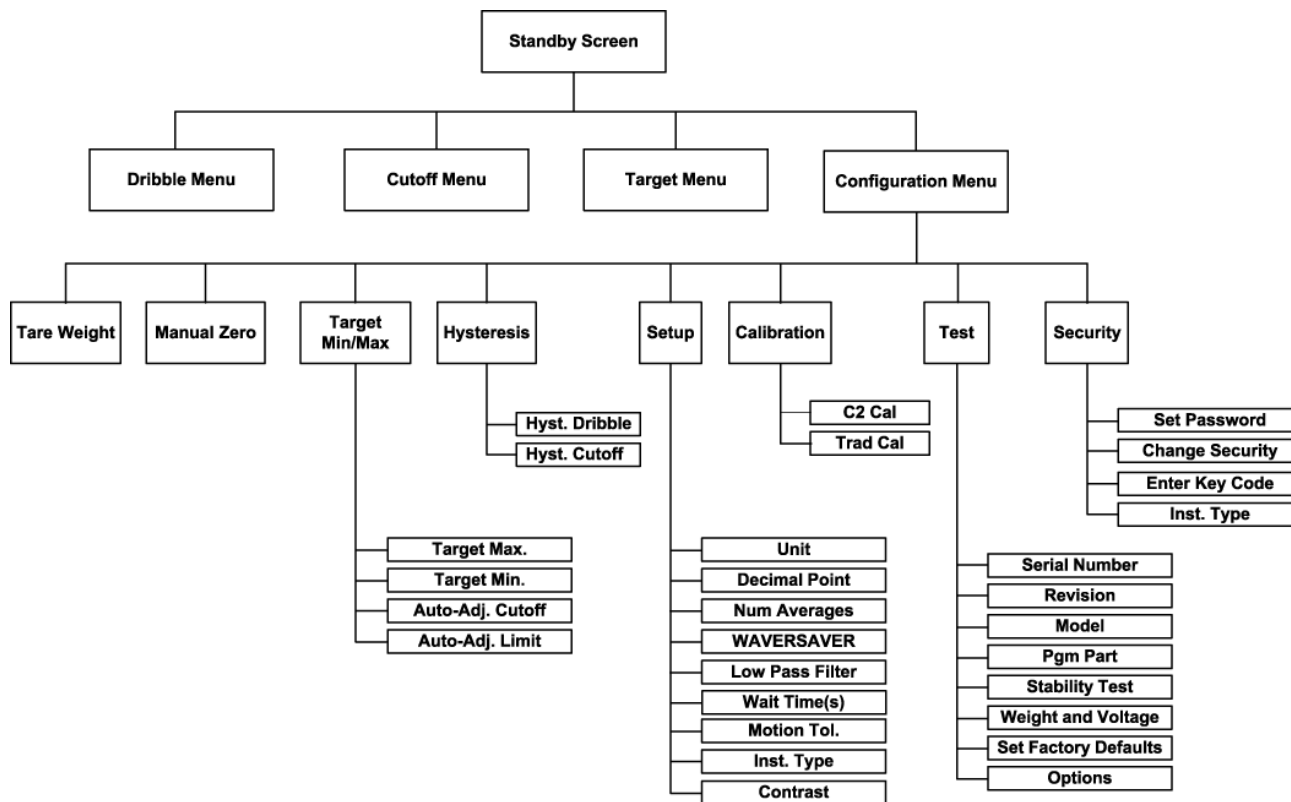

Figure 4-7. T4000 Menu System Block Diagram

On the Standby Screen, each of the four function keys along the bottom of the display has a function tied to it. The button on the left will allow the operator to access the Dribble Menu, where they can set or check the dribble setting.

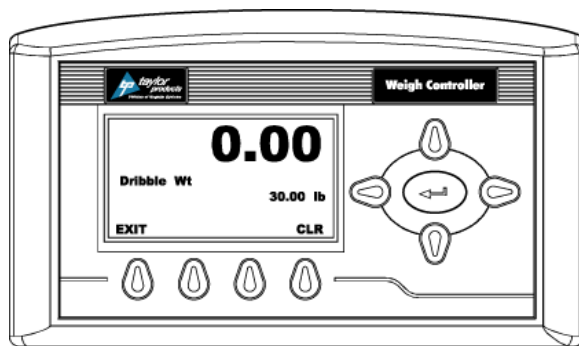

Figure 4-8. Dribble Weight

The button second from the left will allow the operator to access the Cutoff Menu, where they can set or check the cutoff setting.

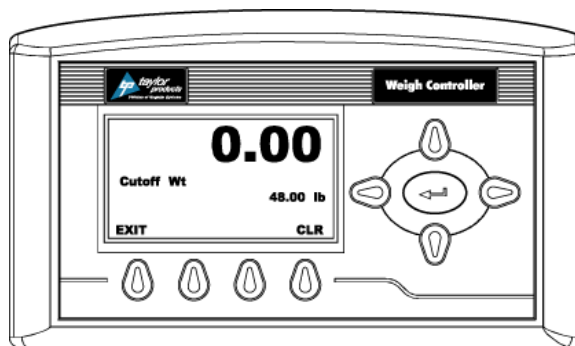

Figure 4-9. Cutoff Menu

The button second from the right will allow the operator to access the Target Menu, where they can set or check the target setting.

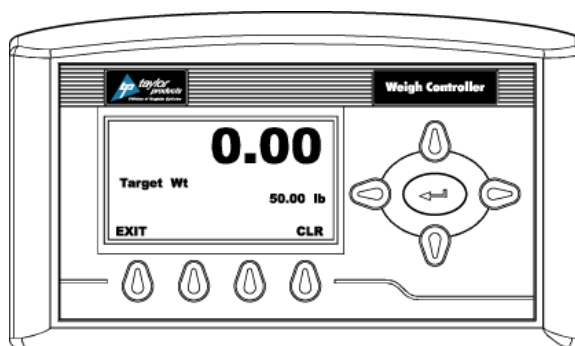

Figure 4-10. Target Weight Menu

The button on the right will allow the operator to access the Configuration Menu. The Configuration Menu allows the operator to access all of the other submenus. Each of the submenus are detailed on the following pages.

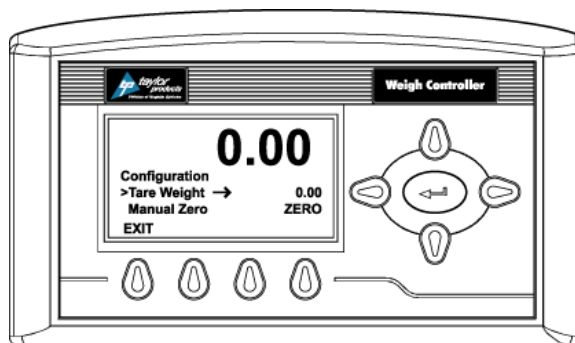

Figure 4-11. Configuration Menu, Tare Weight Setting and Manual Zero Function Shown

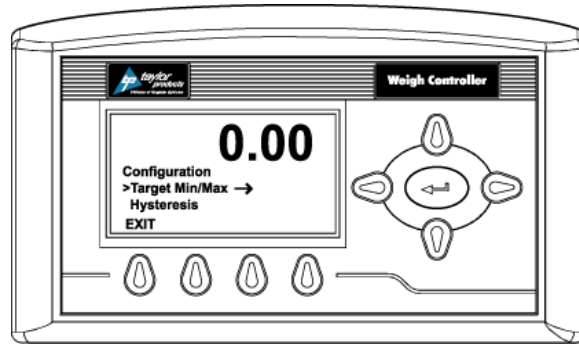

Figure 4-12. Configuration Menu, Target Min/Max and Hysteresis Options Shown

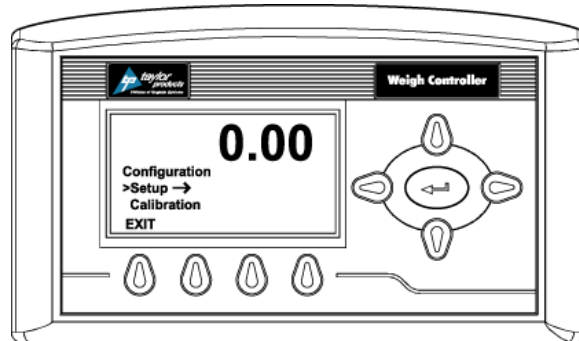

Figure 4-13. Configuration Menu, Setup and Calibration Options Shown

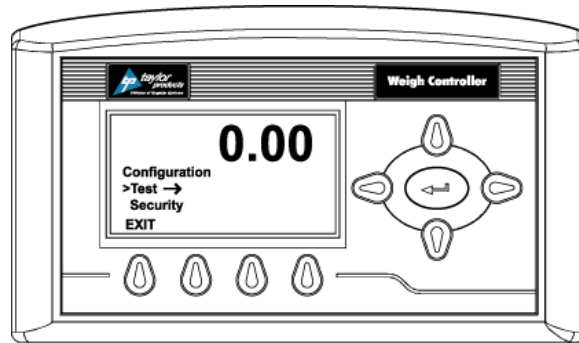

Figure 4-14. Configuration Menu, Test and Security Options Shown

4.2.2.1 Tare Weight Menu

This menu selection allows the operator to set the weigh controller to zero itself after a new package has been installed for filling. When using this feature, it is important that the operator does not have their hand, or anything else coming in contact with any portion of the weigh mechanism. This feature also includes some internal controls to set the Tare Limit and the Min AutoTare.

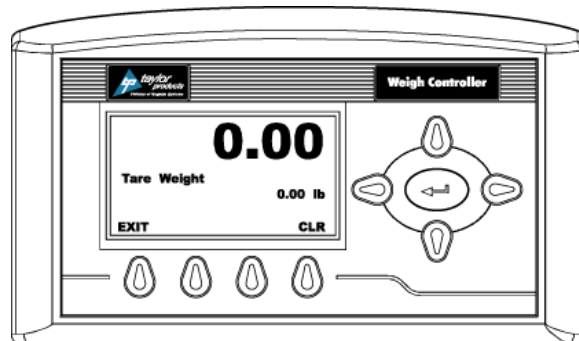

Figure 4-15. Tare Weight Menu

4.2.2.2 Manual Zero Function

From the Configuration Menu, the operator can manually zero the scale. The operator will use the up or down arrow keys to place the cursor (>) in front of the Manual Zero line and will then press the enter key to perform the zero function.

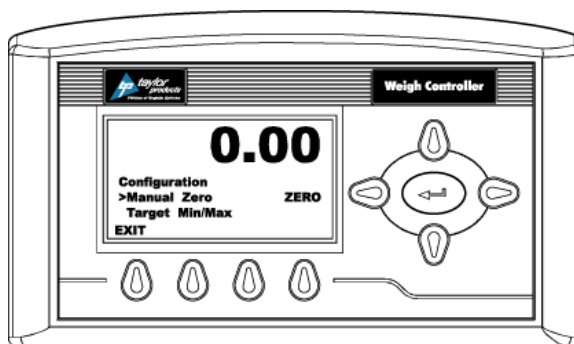

Figure 4-16. Manual Zero Function

4.2.2.3 Target Min/Max Menu

This menu provides the operator with a method to set the maximum and minimum package weights that are acceptable. The T4000 can automatically compensate if a package is over or under weight.

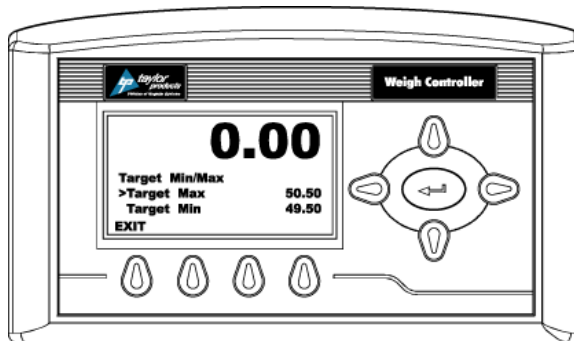

Figure 4-17. Target Min/Max Menu, Max and Min Settings Shown

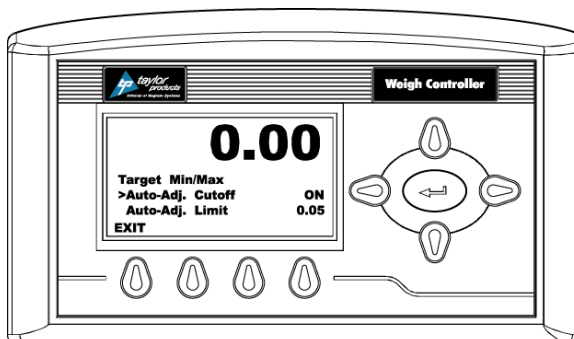

Figure 4-18. Target Min/Max Menu, Auto-Adjust Cutoff and Limit Settings Shown

The following information provides a description of what each of the settings is used for:

- **Target Max** – This is where the operator will set the maximum bag weight that is acceptable.
- **Target Min** – This is where the operator will set the minimum bag weight that is acceptable.
- **Auto-Adj. Cutoff** – The operator will use the arrow keys to toggle this feature on and off.
- **Auto-Adj. Limit** – This line is where the operator will set how much of an adjustment that the controller can make in a single step. For example, if a package comes up 0.2 pounds too heavy, and the operator has this parameter set to 0.10, it will take the controller two fill cycles (packages) to complete the correction.

4.2.2.4 Hysteresis Menu

This menu selection allows the operator to set the Hysteresis value. The Hysteresis value under normal operations will always be a positive value however the Hysteresis value can be set as a negative value should a specific application require it. Hysteresis limits are used to prevent relay chatter once the set point is reached. For example: If a set point value is 100 pounds and the hysteresis is set to 5 pounds, the relay coil is energized at 100 pounds and stays energized until the weight drops to 95 pounds. There are two sub-menus under this selection.

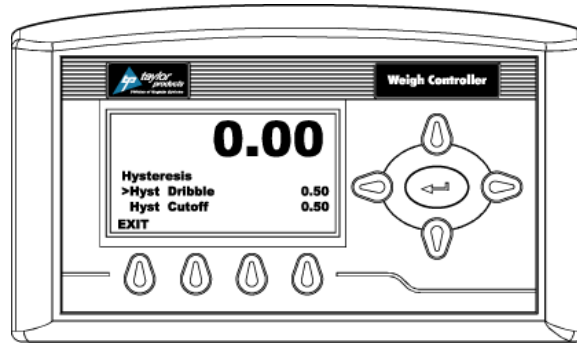

Figure 4-19. Hysteresis Menu

The following information provides a description of what each setting is used for:

- **Hyst Dribble** – This selection allows the operator to set the Hysteresis for Dribble.
- **Hyst Cutoff** – This selection allows the operator to set the Hysteresis for Cutoff.

4.2.2.5 Setup Menu

The Setup Menu allows the operator to setup the basic operating parameters for the machine. Selecting the Setup menu will allow the operator to adjust several items, including:

- **Units** – The operator can select lb (pounds), oz (ounces), lb-oz (pound-ounces), kg (kilograms), or g (grams). The operator will make sure the cursor is placed in front of the Units line, and will then use the left and right arrow keys to scroll through the available unit settings.
- **Decimal** – The operator chooses how many numbers that will show after the decimal point. The operator will place the cursor in front of the Decimal line, and will then use the left arrow key to decrease the number of decimal positions, or the right arrow key to increase the number of decimal positions shown. The minimum is 0 decimal positions, and the maximum is 5 decimal positions.
- **Num Averages** – The operator uses this setting to adjust how sensitive the scale is to vibration, caused by the material flowing into the vessel being weighed. Setting the parameter to its minimum, will result in a faster response from the scale. If weighments are unstable, the parameter should be increased in small increments until a stable reading is achieved. The operator will place the cursor in front of the Num Averages line. The operator will then press the enter key to access the numerical entry screen. The operator will then use the arrow keys to place the cursor under the digit of the number setting that needs changed, then will use the up and down arrow keys to either increase or decrease that digit.

- **WAVERSAVER®** – This parameter can be configured to ignore noise with frequencies as low as 0.25 Hz, and as high as 7.50 Hz. One of four higher additional cut off frequencies may be selected to provide a faster instrument response time. The function is user selectable and can be turned off. Taylor Products recommends a setting of 3.50 Hz for most applications. The operator will place the cursor in front of the WAVERSAVER line, and will then use the left or right arrow keys to scroll through the list of available settings.
- **Low Pass Filter** – The operator can turn this filter ON or OFF. When this parameter is turned on, the meter provides a more stable weight reading but at the expense of the reaction time. In some applications a more stable reading is desired due to the application. If a slower reaction time is acceptable, turn the Low Pass Filter On. For most applications the Low Pass Filter should remain OFF.
- **Wait Time(s)** – This internal timer setting determines the amount of time that the weigh controller will wait after the fill cycle has ended before it will check the weight of the package. This timer can be overridden by the Motion Tolerance value if the Motion Tolerance value is set too low and motion has not ceased at timeout.
- **Motion Tol.** – Used at the start and the end of the fill cycle, this parameter specifies how close weight readings must be to each other before the scale is considered to no longer be in motion. The controller samples the weight readings at one-second increments. These readings are continuously compared to the motion tolerance value. Lower values will result in increased accuracy, but will also slow the controller significantly. A higher value will result in less accuracy, but the controller will be quicker in providing the final package weight. This parameter **MUST** be set to a number higher than 0. Also, a low setting may result in the controller overriding the Wait Timer. The operator will place the cursor in front of the Motion Tol. line and press enter to access the numeric entry screen. The operator will then use the arrow keys to place the cursor under the digit of the number setting that needs changed, then will use the up and down arrow keys to either increase or decrease that digit.
- **Inst. Type** – This line displays how the controller is configured. This information is set at the factory and not changeable.
- **Contrast** – This item allows the operator to adjust the contrast of the display for optimal viewing in their operating environment. The operator will move the cursor in front of the Contrast line and will then use the left and right arrow keys to make the display darker or lighter.

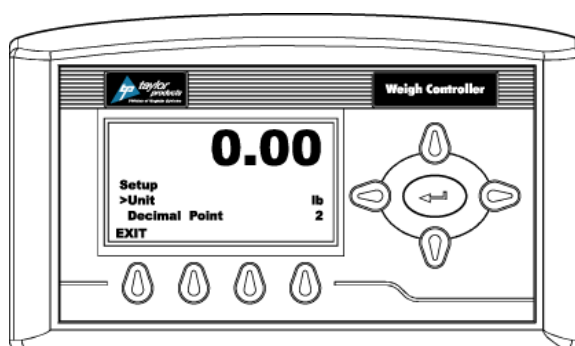

Figure 4-20. Setup Menu, Units and Decimal Point Settings Shown

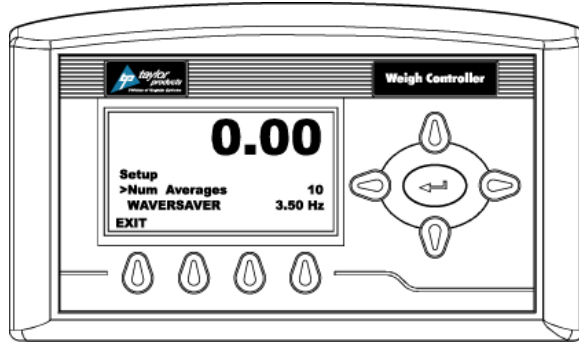

Figure 4-21. Setup Menu, Num Averages and WAVERSAVER Settings Shown

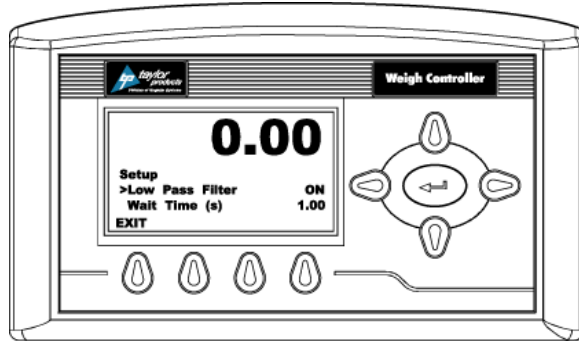

Figure 4-22. Setup Menu, Low Pass Filter and Wait Time(s) Settings Shown

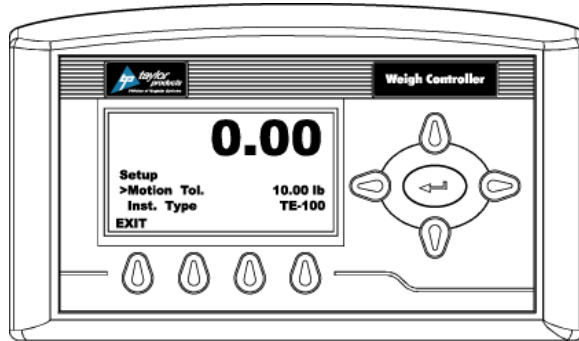

Figure 4-23. Setup Menu, Motion Tolerance and Instrument Type Settings Shown

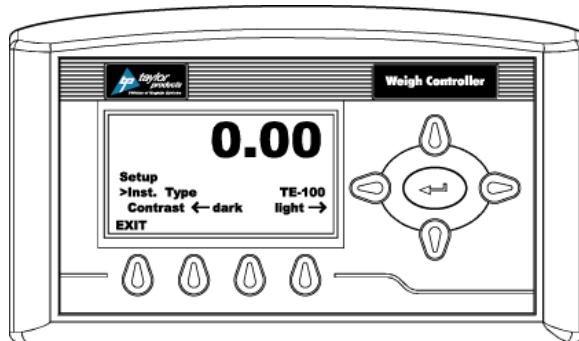

Figure 4-24. Setup Menu, Instrument Type and Contrast Settings Shown

4.2.2.6 Calibration Menu

This menu selection is used when calibrating the controller. The Calibration menu has two sub-menus:

- *C2 Cal* – This menu option is not used.
- *Trad Cal* – This menu option is used to calibrate the controller.

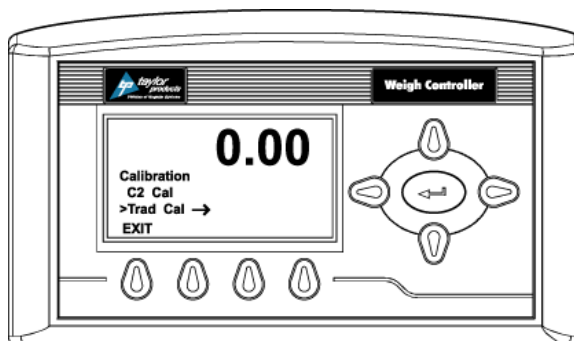

Figure 4-25. Calibration Menu, Trad Cal Highlighted

4.2.2.7 Test Menu

This menu item allows the operator to check certain system parameters and to perform some basic tests.

- *Serial Number* – Lists the serial number of the controller.
- *Revision* – Lists the software revision that is running on the controller.
- *Model* – This line lists whether the unit is a T4000 or a T4000A. It should be set to T4000.
- *Pgm Part* – This line shows the part number of the program that is installed in the controller.
- *Stability Test* – This menu option allows the operator to perform a variance test, raw A/D count, and raw A/D average count.
- *Weight and Voltage* – This menu selection allows the operator to perform a weight test, test DC voltage signals, and RTZ tests.

4.2.2.8 Security Menu

This menu selection allows management to set or change the security parameters for the controller. The Security menu has the following sub-menus:

- *Set Password* – The manager can use this sub-menu to set the system password.
- *Change Security* – The manager can use this sub-menu to turn Security ON or OFF.
- *Enter Key Code* – Key codes are required to change the configuration of the controller. For example, if the controller is a dual set point unit, and the manager wants to change to a triple set point configuration, the manager may purchase a key code for that specific controller to unlock that feature. The serial number of the controller must be provided to Taylor Products Customer Service to obtain a key code. The Key code is only for the controller with that serial number. It is not interchangeable with other T4000/T4000A controllers.
- *Inst. Type* – This line is set at the factory. It requires a key code to be changed.

Important: *The password is set at the factory to 2205. The manager may reset this password to a four-digit sequence of their choice, at their discretion.*

4.3 Initial Setup

Use the steps below to perform the initial setup on the TE100.

1. Connect the main electrical and pneumatic connections.
2. Turn the TE100 on.
3. Allow the unit to warm up for fifteen (15) minutes.
4. If the unit has not been calibrated, calibrate it at this time. Refer to 3.6 Calibration.
5. Set the dribble setting.
 - a. Press the function key below DRIB on the Standby screen. The DRIB menu will appear.
 - b. Use the arrow keys to adjust the DRIB setting.
 - c. Press the enter button to save the setting and to return to the Standby menu.
6. Set the cutoff setting.
 - a. Press the function key below CUTOFF on the Standby screen. The CUTOFF menu will appear.
 - b. Use the arrow keys to adjust the CUTOFF setting.
 - c. Press the enter button to save the setting and to return to the Standby menu.

***Note:** After a little experience with each material, adjustments to the CUTOFF setting can be made to minimize fill time while maintaining required weighment accuracy. The optimum dribble weight setting is usually when there are about two seconds of dribble flow before complete cutoff at target weight.*

7. Zero (tare) the weight meter.
 - a. If the weighments are to be based on **Gross Weight**, zero the weigh meter with no bag on the spout.
 - b. If the weighments are to be based on **Net Weight**, zero the weigh meter with a bag attached to the spout.
 - c. Tare weight – Manually enter the Tare Weight of the bag. The controller will automatically account for the tare value.
8. Place an empty bag on the spout.



WARNING

Be sure to keep fingers and loose clothing away from bag clamps. Failure to do so could result in personal injury.

9. Engage the start switch. The automatic fill cycle will begin.

***Note:** To stop the machine during a fill cycle, press the STOP button/indicator on the front of the control panel.*



CAUTION

Never pull down on a bag to stop a fill cycle. Failure to follow this instruction could result in personal injury or damage to the load cell.

10. If the fill cycle stops, but the bag does not drop, the weight of the bag is outside of the Target Min./Max. reject points. Press the STOP button/indicator located on the front of the control panel to drop the bag.

11. Due to the pre-programmed Automatic Adjust Cutoff Value, the first bags of each run may be overweight. Each succeeding bag should get closer to the target weight. It will require 5 to 12 bags of material before the Automatic Adjust Cutoff will be able to fully correct to Target Weight. However, if the first bag is substantially over weight (more than 2 pounds), use the following procedure to reduce the amount of bags required for the Automatic Adjust Cutoff to reach Target Weight. If the first bag is 2 pounds or less overweight, skip ahead to Step 12.
12. Adjust the dribble gate. The dribble gate controls the amount of product flowing through the TE100. If the TE100 is filling a 50 pound bag in less than 4 seconds and the bag weights are erratic, close the dribble gate a little. This should restrict the flow and stabilize the bag weights. If bag weights are very stable and fill times are slow, open the dribble gate to reduce fill time. Try different adjustments of the dribble gate until you find the optimum combination of minimum fill times with acceptable bag weight stability.
13. Setup of the unit is now complete. The unit should be ready to be placed in normal operation.

4.4 Normal Operation (Typical Fill Cycle)

Once the unit has been properly set up, normal operation will consist of the following steps:

1. Place a bag on the spout.



WARNING

Be sure to keep fingers and loose clothing away from bag clamps. Failure to do so could result in personal injury.

2. Trip the rod on the start switch. The bag clamp will close down on the bag clamp pads to hold the bag in place. The shutoff gate will open to start the fill cycle.
3. When the bag reaches the dribble weight, the dribble gate cylinder will extend, pushing the dribble gate inward. This will partially obstruct the flow path, which slows the product flow.
4. When the bag reaches the cutoff weight, the shutoff gate will close, stopping the flow of product.
5. The product in free fall will settle into the bag to bring the final weight to the Target Weight.
6. The bag clamp will retract, dropping the bag from the spout.
7. The operator will remove the filled bag from under the spout and start at step 1 with a new bag.

***Note:** If the bag clamp jaws fail to open and drop a bag after the fill cycle is complete, it is probably due to the bag being either over or under the acceptable weight limits that have been set with the Target Min./Max. feature. To manually drop the rejected bag from the spout, press the STOP button/indicator on the front of the control panel.*

***Important:** Never pull down on an underweight bag to get it to “make weight” and drop. Follow company procedures for disposition of overweight or underweight bags.*

Important:** To stop a fill cycle at any time for any reason, press the STOP button located on the front of the control box. **NEVER PULL DOWN ON A BAG TO STOP THE FILL CYCLE.

4.4.1 Maintaining Operational Efficiency

To ensure the unit operates at maximum efficiency the operator must:

1. Make sure the unit is properly set up and adjusted, including dribble gate position, dribble weight setting, and target min./max. set points.
2. Feed a steady supply of empty bags to the spout.
3. Make sure a uniform, uninterrupted flow of material reaches the unit from the overhead hopper.

This Page Intentionally Left Blank

Chapter 5

Preventive Maintenance

5.1 General Description

To minimize downtime and maintain operational efficiency, preventive maintenance should be made a priority. Proper preventive maintenance practices will also extend the life of the equipment. Developing a preventive maintenance schedule will ensure that critical maintenance procedures are not missed.

5.2 Daily Maintenance Procedures

At the start of each working day, the following maintenance tasks should be performed before starting the machine:

1. Thoroughly clean the machine.
2. Check the calibration, using a known weight.

5.2.1 Cleaning

Keeping the TE100 clean is an important part of the daily maintenance tasks. Remove any dust and/or dirt that will accumulate on a daily basis. Keeping the unit clean will keep debris from entering the control mechanisms, which could cause the performance of the TE100 to suffer. Also, by taking the time to clean the TE100 on a daily basis, the operator will be able to give the TE100 a thorough inspection. Take the time to inspect all components for possible damage, and check all fasteners to make sure they remain tight.

5.2.2 Check Calibration

On a daily basis, check the calibration of the machine using a known weight. If calibration is required, refer to 3.6 Calibration.

5.3 Monthly Maintenance

On a monthly basis (every 700 operating hours), the operator should perform the following steps:

1. Inspect and service the filter and lubricator in the FRL.
2. Inspect all hoses, air cylinders, linkages, and bearings. Replace any worn or damaged parts.
3. Inspect the rubber shutoff gate seal. Replace the seal if it is worn or leaking.
4. Clean any dust or product that may have accumulated around the load cell.
5. Inspect the rubber bag clamp pads. Replace them if they are worn.
6. Check the calibration. Refer to 3.6 Calibration.
7. Check the retainer flange bolts. Tighten them if they are loose.

This Page Intentionally Left Blank

Chapter 6

Troubleshooting

6.1 General Description

When a problem occurs, proper troubleshooting techniques will allow maintenance personnel to quickly identify the problem.

6.2 The Troubleshooting Process

The actual troubleshooting process is just as important as the repair process. Use the following troubleshooting keys to assist with the troubleshooting process:

- Identify the trouble symptom
 - What is the problem?
 - What were the circumstances when the problem occurred?
 - Could weather be a factor?
 - Are there any other contributing factors?
- Sectionalize the problem
 - Look at the problem.
 - What area of the machine is the problem occurring in?
 - Has anything changed recently?
- Isolate the problem
 - Try simple things first.
 - Observe indication and trouble codes.
 - Check test points.
 - Avoid complicating the problem.

6.3 Trouble Symptoms

Use the following information to assist in troubleshooting.

6.3.1 Scale is Not Accurate

If the scale is providing inaccurate readings, check the following:

1. Check the calibration of the TE100. Refer to Chapter 3.6 Calibration.
2. Check for anything that might interfere with the natural motion of the spout. Any items, such as cords, hoses, etc., that would impede or change the movement of the spout must be removed.
3. Check spout to make sure it is not rubbing on the scale cabinet. If the spout touches the scale cabinet, it will cause the inconsistent weighments.
4. Check the hopper to make sure an adequate supply of material is available in the product hopper to ensure a consistent head pressure.
5. Check to make sure there is nothing restricting material flow from the hopper.
6. Check that hoses or other components are not coming into contact with the spout.

6.3.2 Scale Does Not Return to Zero

If the scale reading does not return to zero after package has been removed from the spout, check the following items:

1. Check the calibration of the TE100. Refer to Chapter 3.6 Calibration.
2. Check for anything that might interfere with the natural motion of the spout. Any items, such as cords, hoses, etc., that would impede or change the movement of the spout must be removed.
3. Check spout to make sure it is not rubbing on the scale cabinet. If the spout touches the scale cabinet, it will cause the inconsistent weighments.
4. Check to see if product is building up and sticking inside the spout.

6.3.3 The Machine Is Unable To Auto Correct To The Target Weight

If the Automatic Cutoff Adjust feature is unable to adjust the fill cycle so that the package weight matches the desired target weight, follow the steps below:

1. Adjust the setting for the Automatic Adjust Cutoff feature. Refer to 3.6.2 Setting Auto Adjust Cutoff.
2. Adjust the actuation speed of the shut off gate. Adjust as necessary. Refer to 7.2.3 MAC Valve Flow Control Adjustment.

6.3.4 The Weighments Fluctuate Between Too Light and Too Heavy

If the TE100 is inconsistent in delivering package weights, and the weights are always either too heavy, or too light, follow the steps below:

1. Verify that the product flow is consistent and stable.
2. Check for consistent head pressure of product above the machine. Head pressure is the amount of product that is always in the hopper immediately above the TE100. It is very important to keep the TE100 from running out of material. As the TE100 runs out of product the weighment accuracy will vary widely. A good rule of thumb is to have enough product in the hopper to fill approximately 20 packages at all times. This amount may vary slightly depending upon product characteristics.
3. Check the calibration of the TE100. Refer to Chapter 3.6 Calibration.

6.3.5 Filled Bag Won't Drop

If the bag does not drop at the end of the fill cycle, check the following:

1. Check the package weight. If the package weight is outside of the acceptable over/under range. If the weight is outside this range, the operator will have to manually release the package by pressing the STOP button/indicator.

Note: If packages are consistently finishing outside of the acceptable target min./max. range, check the target min./max. range settings to make sure the settings are not too restrictive. It may be necessary to adjust them.

2. Check the function of the MAC valve that controls air flow to the bag clamp cylinders for proper operation.

6.3.6 Bag Won't Stop Filling

If the bag does not drop at the end of the fill cycle, check the following:

1. Check the start switch to make sure that it isn't being held in the on position. At the start of the fill cycle, the switch must "make" contact to start the cycle, and it must return to the neutral (open) position before the fill cycle completes. Check the top of the bag to make sure that it is not holding the start switch in the "make" position.

6.3.7 Pneumatic Cylinder Failure

Occasionally a cylinder may fail or may operate intermittently. Check the operation of the suspected cylinder using the steps below:

1. Remove the air hose from the unpressurized side of the cylinder and see if any air leaks through from the pressurized side. Reinstall the hose.
2. Reverse the pressure on the cylinder.
3. Remove the other hose. It should now be on the unpressurized side of the cylinder. Check for any leaks through from the pressurized side. Reinstall the hose.
4. Check for air leaks around the barrel end of the cylinder.
5. If leaks are found in any of the steps, replace the air cylinder.

6.3.8 MAC Valve Failure

Occasionally a MAC valve may fail or may operate intermittently. Check the operation of the suspected MAC valve using the steps below:

1. With the power off, press the manual override buttons (test buttons) on the cylinder coils to cause the cylinder spool to function. If the valve does not function in manual mode, replace the valve.
2. Check the wiring to the cylinder coils from the T4000. Make sure the wiring energizes the coil as the relays on the meter board change. If the wiring to the coils is energizing the proper coil at the proper time, but the MAC valve fails to function, replace the MAC valve.
3. If the wiring to the coils is not being energized at the proper time, use a voltmeter to check the relays on the weigh meter circuit board. There is a normally open and a normally closed contact on each relay and each should change as the weights reach the dribble and target weight set points. If the relays do not operate correctly, replace the circuit board.

This Page Intentionally Left Blank

Chapter 7

Repair and Adjustment

7.1 General Description

When troubleshooting procedures have indicated that a component needs to be repaired, replaced, or adjusted, following the repair procedures contained in this chapter will assist maintenance personnel to return the machine to operation in a timely manner.

7.2 System Adjustments

Depending on how the TE100 is configured, there are several adjustments that may be required from time to time. They are:

- Bag clamp adjustment
- Shut off gate adjustment
- MAC valve flow control adjustment

7.2.1 Bag Clamp Adjustment

1. Turn the TE100 off.
2. Disconnect the main electrical and pneumatic connections.
3. Disconnect the air supply lines from the bag clamp cylinder quick connect fittings.
4. Remove the start switch.
5. Remove the spout. Refer to 7.3.1 Spout Replacement.
6. Loosen the jam nut on the cylinder shafts above the pivot blocks.

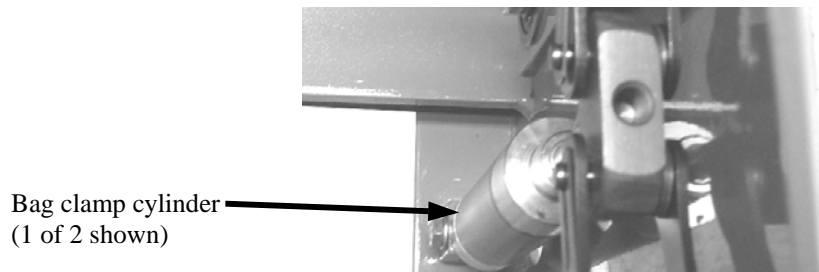

Figure 7-1. Bag Clamp Cylinder and Pivot Block Location

7. Adjust the cylinder rods by threading them into or out of the pivot blocks. Backing them out of the pivot blocks will increase the clamp travel. Threading them into the pivot blocks will decrease the clamp travel.

Important: When adjusting the cylinder rods, make sure that they are adjusted equal amounts.

8. Tighten jam nuts on the cylinder rods against the pivot blocks.
9. Install the spout. Refer to 7.3.1 Spout Replacement.
10. Install the start switch.
11. Connect the air supply lines to the bag clamp cylinder quick connect fittings.
12. Connect the main electrical and pneumatic connections.
13. Turn the TE100 on and test for proper operation.

7.2.2 Shut Off Gate Adjustment

1. Turn the TE100 off.
2. Disconnect the main electrical and pneumatic connections.
3. Disconnect the air supply lines from the bag clamp cylinder quick connect fittings.
4. Remove the start switch.
5. Remove the spout. Refer to 7.3.1 Spout Replacement.
6. Inspect the rubber shut off gate seal for wear or damage. Replace if necessary. Refer to 7.3.7 Shut Off Gate Seal Replacement.
7. Loosen the jam nut on the shut off gate cylinder rod.
8. Turn the cylinder rod in the rod end to adjust the amount of contact between the edge of the shut off gate and the shut off gate seal.

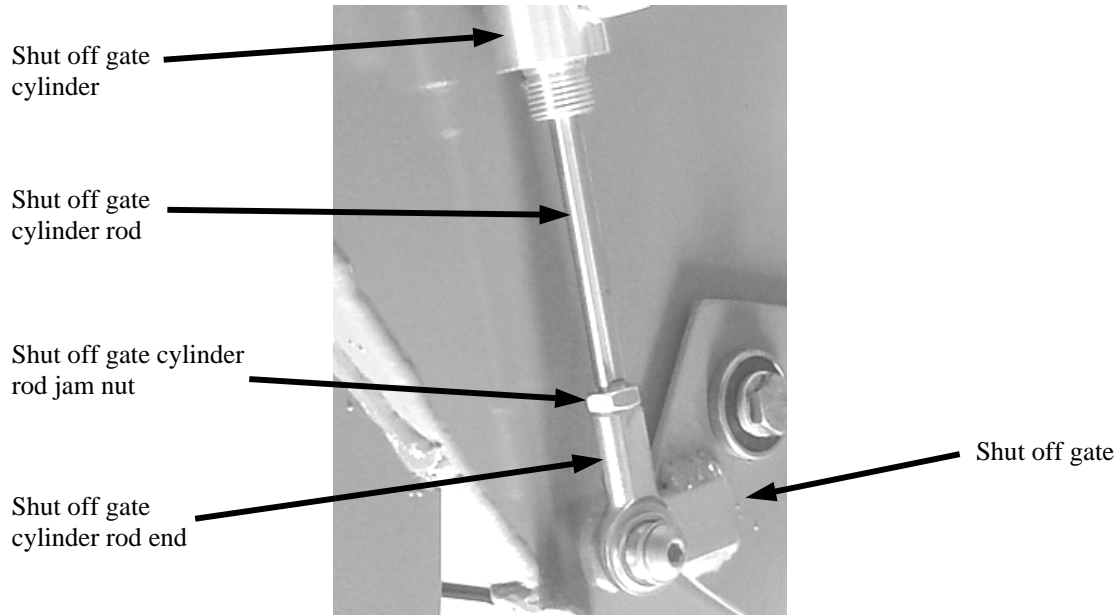

Figure 7-2. Shut Off Gate Adjustment

9. Tighten the jam nut against the rod end.
10. Install the spout. Refer to 7.3.1 Spout Replacement.
11. Install the start switch.
12. Connect the air supply lines to the bag clamp cylinder quick connect fittings.
13. Connect the main electrical and pneumatic connections.
14. Turn the TE100 on and test for proper operation.

7.2.3 MAC Valve Flow Control Adjustment

If the operator has determined that the actuation speed of a pneumatic component is either too fast or too slow, the operator can adjust the actuation speed of that component by adjusting the flow control on the MAC valve that controls that pneumatic component. Use the steps below to adjust the airflow from the MAC valve.

1. Locate the MAC valve that controls the affected component.
2. Locate the flow control screw on the top of the MAC valve.
3. Using a screwdriver turn the flow control screw. To increase the actuation speed, turn the adjustment screw counter-clockwise. To decrease the actuation speed, turn the adjustment screw clockwise.

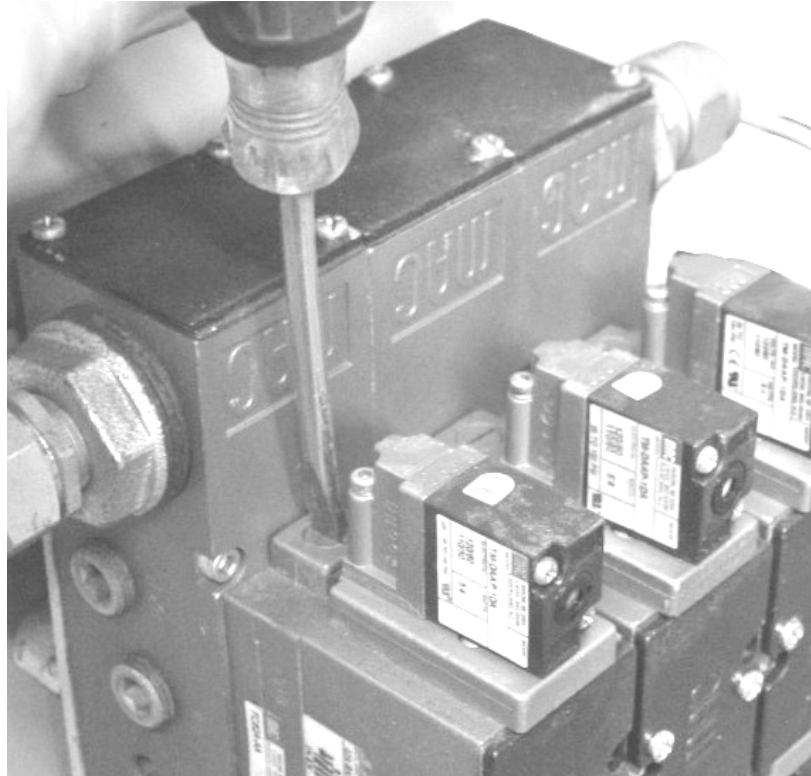

Figure 7-3. Adjusting Airflow From The MAC Valve

7.3 System Repairs

Over time, components on the TE100 may become worn or damaged. If this occurs, follow the procedures in this section to repair or replace individual components.



WARNING

When replacing parts, it is critical that only parts approved by Taylor Products are used.

7.3.1 Spout Replacement

If the spout becomes damaged or worn, use the procedures below to replace it.

7.3.1.1 Spout Removal

1. Turn the TE100 off.
2. Disconnect the main electrical and pneumatic connections.
3. Label and disconnect the air supply lines that are connected to the bag clamp cylinders.

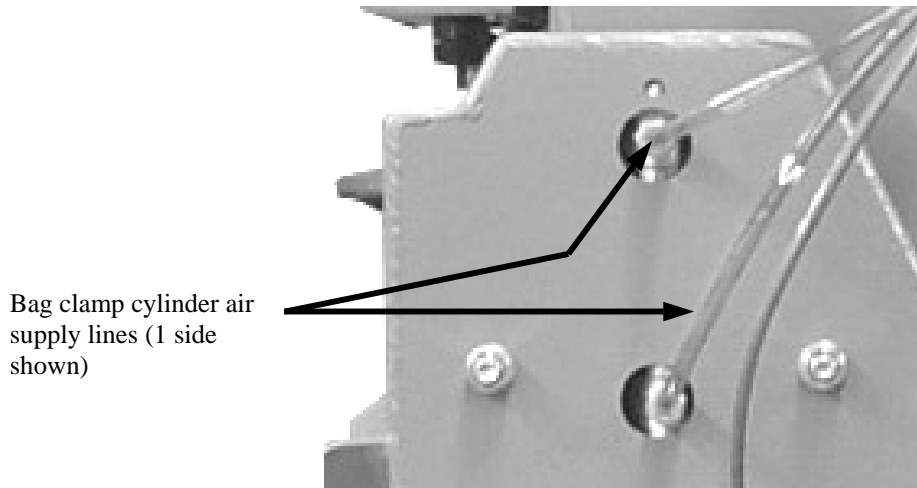

Figure 7-4. Bag Clamp Cylinder Air Supply Lines (1 Side Shown)

4. Remove the bag clamp actuator switch.
5. Remove the start switch.
6. Remove the two spout mounting bolts.
7. Remove the spout by lifting it up slightly, and sliding it toward the rear of the TE100, then lowering it until it clears the load cell



CAUTION

A sudden jerk or shock, such as being struck by a tool or hitting the spout, etc., can cause load cell damage. The load cell is NOT covered by warranty.

8. Lower the spout until it clears the scale cabinet. Set the spout assembly aside.

***Note:** If the spout is being replaced, follow the procedures in this chapter to transfer the components that are mounted to the spout over to the new spout.*

7.3.1.2 Spout Installation

1. Lift the spout and align it so that the bottom of the scale cabinet is slipping into the spout.
2. Once the lip of the spout is above the load cell, slide the spout forward and line the mounting holes on the spout up with the mounting holes in the load cell.
3. Lower the spout onto the load cell.



CAUTION

A sudden jerk or shock, such as being struck by a tool or hitting the spout, etc., can cause load cell damage. The load cell is NOT covered by warranty.

4. Install the two mounting bolts. Do not tighten the bolts yet.

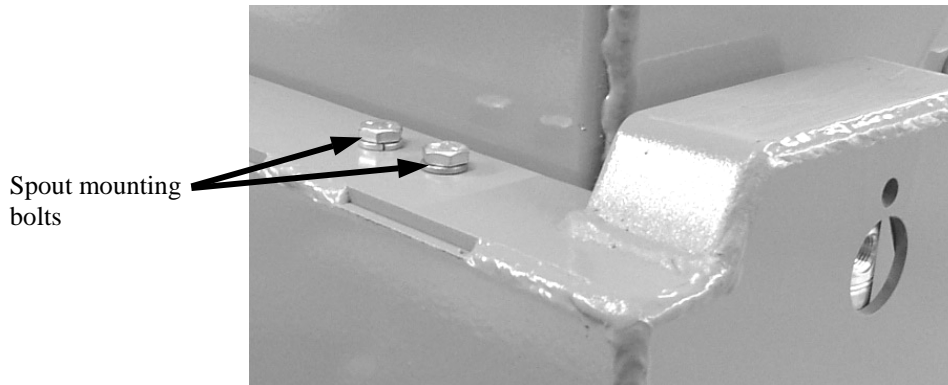

Figure 7-5. Spout Mounting Bolts

5. Check the alignment of the spout to the scale cabinet. The spout should not be touching the scale cabinet. The only contact with the scale cabinet or with its components should be where the spout sits on the load cell.
6. Tighten the spout to load cell bolts. Do not over tighten.
7. Install the start switch.
8. Install the bag clamp actuator switch.
9. Connect the air supply lines that feed the bag clamp cylinders.
10. Connect the main electrical and pneumatic connections.
11. Turn the TE100 on and test for proper operation.

7.3.2 Load Cell Replacement

If a load cell becomes damaged or fails to function, the following procedure should be used to replace the load cell.



CAUTION

A sudden jerk or shock, such as being struck by a tool or hitting the spout, etc., can cause load cell damage. The load cell is NOT covered by warranty.

7.3.2.1 Load Cell Removal

1. Turn the TE100 off.
2. Disconnect the main electrical and pneumatic connections.
3. Remove the spout. Refer to 7.3.1 Spout Replacement.
4. Open the control box and locate the load cell connections.
5. Make a note of each connection point and the color of wire that is connected to it.
6. Disconnect the load cell connections.
7. Pull the load cell cable free of the control box.
8. Remove any tie straps that are securing the load cell cable to the frame of the TE100.
9. Loosen and remove the load cell mounting bolts.
10. Remove the load cell.

7.3.2.2 Load Cell Installation

1. Position the load cell.
2. Install the two mounting bolts, but do not tighten them.
3. Check the alignment of the load cell. The side of the load cell should run parallel to the scale cabinet. Tighten the load cell mounting bolts when the load cell is parallel to the scale cabinet.

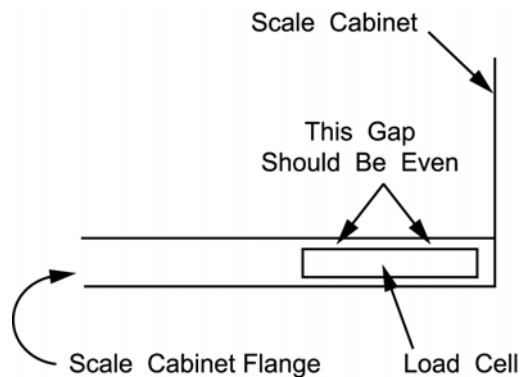

Figure 7-6. Checking Load Cell Alignment (As Viewed From The Top Of The TE100)

4. Route the load cell cable to the control box in the same manner as the cable from the load cell that was removed.
5. Insert the cable into the control box.
6. Connect the load cell cable to the controller and close the control box.
7. Install the spout. Refer to 7.3.1 Spout Replacement.
8. Connect the main electrical and pneumatic connections.
9. Turn the TE100 on.
10. Calibrate the TE100. Refer to 3.6 Calibration.

7.3.3 Dribble Gate Cylinder Replacement

If the dribble gate cylinder develops a leak, or is receiving air pressure and fails to function, use the procedures below to replace it.

7.3.3.1 Dribble Gate Cylinder Removal

1. Turn the TE100 off.
2. Disconnect the main electrical and pneumatic connections.
3. Remove the back cover.
4. Label and disconnect the air supply lines from the dribble gate cylinder.
5. Remove the nut, washer, and bolt that secure the rod end of the cylinder to the dribble gate.
6. Loosen and remove the bolt that secures the cylinder to the cylinder mounting bracket.
7. Remove the dribble gate cylinder.

7.3.3.2 Dribble Gate Cylinder Installation

1. Position the dribble gate cylinder so that the mounting hole on the cylinder end lines up with the mounting hole in the mounting bracket.
2. Install the bolt that secures the dribble gate cylinder to the mounting bracket.
3. Line the rod end of the pneumatic cylinder with the bolt hole on the mounting tab on the dribble gate.
4. Insert the bolt through the rod end and mounting tab.
5. Install the washer and nut on the bolt. Tighten the nut on the bolt.
6. Connect the air supply lines to the dribble gate cylinder.
7. Connect the main electrical and pneumatic connections.
8. Turn the TE100 on and test for proper operation.

7.3.4 Dribble Gate Replacement

If the dribble gate becomes damaged or worn, use the steps below to replace it.

7.3.4.1 Dribble Gate Removal

1. Turn the TE100 off.
2. Disconnect the main electrical and pneumatic connections.
3. Remove the dribble gate cylinder. Refer to 7.3.3 Dribble Gate Cylinder Replacement.
4. Remove the dribble gate cylinder mounting bracket bolts and bracket.
5. Slide the dribble gate upward and to the rear of the TE100 until it is clear of the scale cabinet.

7.3.4.2 Dribble Gate Installation

1. Slide the dribble gate into the slots that the gate rides in.
2. Install the dribble gate cylinder mounting bracket.
3. Install the dribble gate cylinder. Refer to 7.3.3 Dribble Gate Cylinder Replacement.
4. Connect the main electrical and pneumatic connections.
5. Turn the TE100 on and test for proper operation.

7.3.5 Shut Off Gate Cylinder Replacement

If the shut off gate cylinder develops a leak, or is receiving air pressure and fails to function, use the procedures below to replace it.

7.3.5.1 Shut Off Gate Cylinder Removal

1. Turn the TE100 off.
2. Disconnect the main electrical and pneumatic connections.
3. Remove the spout. Refer to 7.3.1 Spout Replacement.
4. Label and disconnect the air supply lines from the shut off gate cylinder.
5. Remove the bolt that secures the rod end of the cylinder to the shut off gate.
6. While holding the shut off gate cylinder with one hand, remove the bolt that secures the cylinder end to the scale cabinet.
7. Remove the cylinder.

7.3.5.2 Shut Off Gate Cylinder Installation

1. Position the cylinder so that the mounting tab is positioned in mounting bracket and so that the air fittings are facing away from the scale cabinet.
2. Line the rod end of the cylinder up with the mounting hole in the shut off gate.
3. Install the bolt that secures the rod end of the cylinder with the shut off gate.
4. Connect the air supply lines to the quick connect fittings on the shut off gate cylinder.
5. Install the spout. Refer to the 7.3.1 Spout Replacement.
6. Connect the main electrical and pneumatic connections.
7. Turn the TE100 on and test for proper operation.

7.3.6 Shut off Gate Replacement

If the shut off gate becomes worn or damaged, follow the procedures below to replace it.

7.3.6.1 Shut Off Gate Removal

1. Turn the TE100 off.
2. Disconnect the main electrical and pneumatic connections.
3. Make sure that the hopper and the scale cabinet are empty.
4. Remove the spout. Refer to the 7.3.1 Spout Replacement.
5. Remove the shut off gate cylinder. Refer to the 7.3.5 Shut Off Gate Cylinder Replacement.
6. Open the shut off gate.
7. Use a screwdriver to hold one of the slotted screws on the inside of the scale cabinet, while using a wrench to loosen and remove the nut on that screw on the outside of the shut off gate.

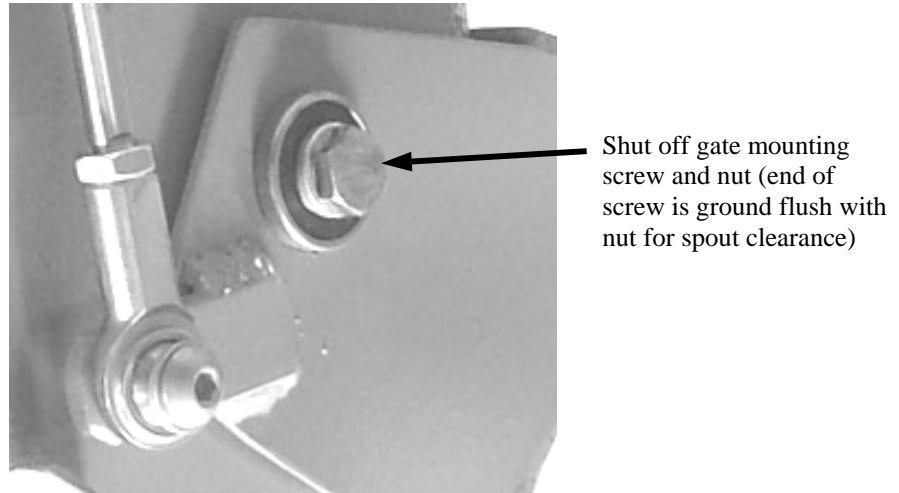

Figure 7-7. Shut Off Gate Mounting

8. While holding the shut off gate with one hand, remove the shut off gate mounting bolts.
9. Remove the shut off gate.

7.3.6.2 Shut Off Gate Installation

1. Position the shut off gate so that the mounting holes are lined up with the mounting holes in the scale cabinet.
2. Insert the two slotted screws through the mounting holes. The heads of the screws should be inside the scale cabinet.
3. Install and tighten the nuts on each of the two slotted screws. Do not over tighten.
4. Use a grinder to grind any portion of the screw shank that extends beyond the outer surface of the nut. This is done to provide clearance for mounting the spout.



Figure 7-8. Shut Off Gate Mounting Screw Ground Off Smooth

5. Install the shut off gate cylinder. Refer to the 7.3.5 Shut Off Gate Cylinder Replacement.
6. Install the spout. Refer to the 7.3.1 Spout Replacement.
7. Connect the main electrical and pneumatic connections.
8. Turn the TE100 on and test for proper operation.

7.3.7 Shut Off Gate Seal Replacement

If the shut off gate seal becomes worn, damaged, or is leaking, use the procedures below to replace it.

7.3.7.1 Shut Off Gate Seal Removal

1. Turn the TE100 off.
2. Disconnect the main electrical and pneumatic connections.
3. Remove the spout assembly. Refer to 7.3.1 Spout Replacement.
4. Open the shut off gate.
5. Remove the nuts from the shut off gate seal.
6. Remove the shut off gate seal.

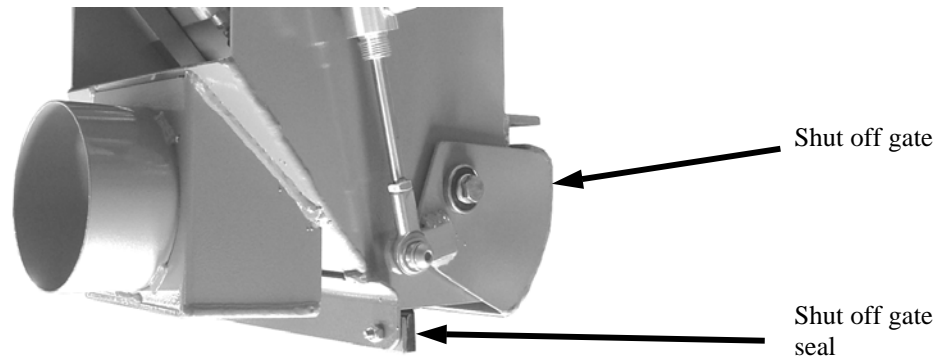

Figure 7-9. Shut Off Gate Seal

7.3.7.2 Shut Off Gate Seal Installation

1. Position the shut off gate seal.
2. Install and tighten the nuts from the shut off gate seal.
3. Close the shut off gate.
4. Install the spout assembly. Refer to 7.3.1 Spout Replacement.
5. Connect the main electrical and pneumatic connections.
6. Turn the TE100 on and test for proper operation.

7.3.8 Bag Clamp Arm Replacement

If a bag clamp arm becomes damaged or worn, follow the steps below to replace it.

7.3.8.1 Bag Clamp Arm Removal

1. Turn the TE100 off.
2. Disconnect the main electrical and pneumatic connections.
3. Make sure that the hopper and the scale cabinet are empty.
4. Remove the spout. Refer to the 7.3.1 Spout Replacement.
5. Place the spout assembly on a workbench upside down.
6. Disconnect the chain links from the bag clamp arm being replaced.
7. Remove the bag clamp arm spring. Refer to 7.3.9 Bag Clamp Arm Spring Replacement.
8. Remove the bag clamp cylinders. Refer to 7.3.10 Bag Clamp Cylinder Replacement.
9. Remove the nuts from the bag clamp arm mounting bolts.
10. Remove the bag clamp arm mounting bolts and bearings.
11. Remove the bag clamp arm.

7.3.8.2 Bag Clamp Arms Installation

1. Install three stainless steel washers on one pin on each of the chain links.
2. Insert the pin with the washers through the chain link mounting hole on the bag clamp arm.
3. Position the bag clamp arm. The one with the stainless steel deflector goes on the rear (open) side of the spout.

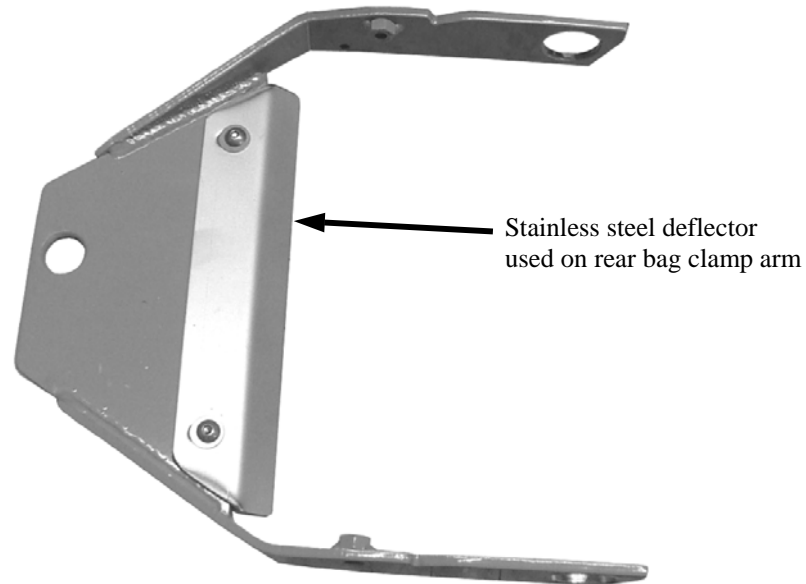

Figure 7-10. Stainless Steel Deflector

4. Install the bag clamp arm mounting bolts and bearings from the inside of the spout assembly.

Important: Three of the bolts used are standard hex head bolts. One bolt is an internal hex bolt. This bolt must be installed in the proper location. Failure to do so will result in improper operation of the TE100. Refer to Figure 7-11 for more information.

Note: If the bearings won't slide into the bag clamp arms, it may be necessary to clean the holes out.

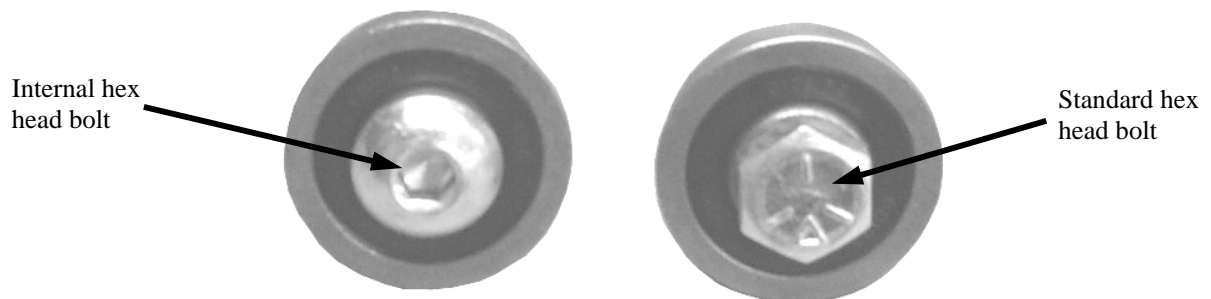

Figure 7-11. Bag Clamp Arm Bolts and Bearings

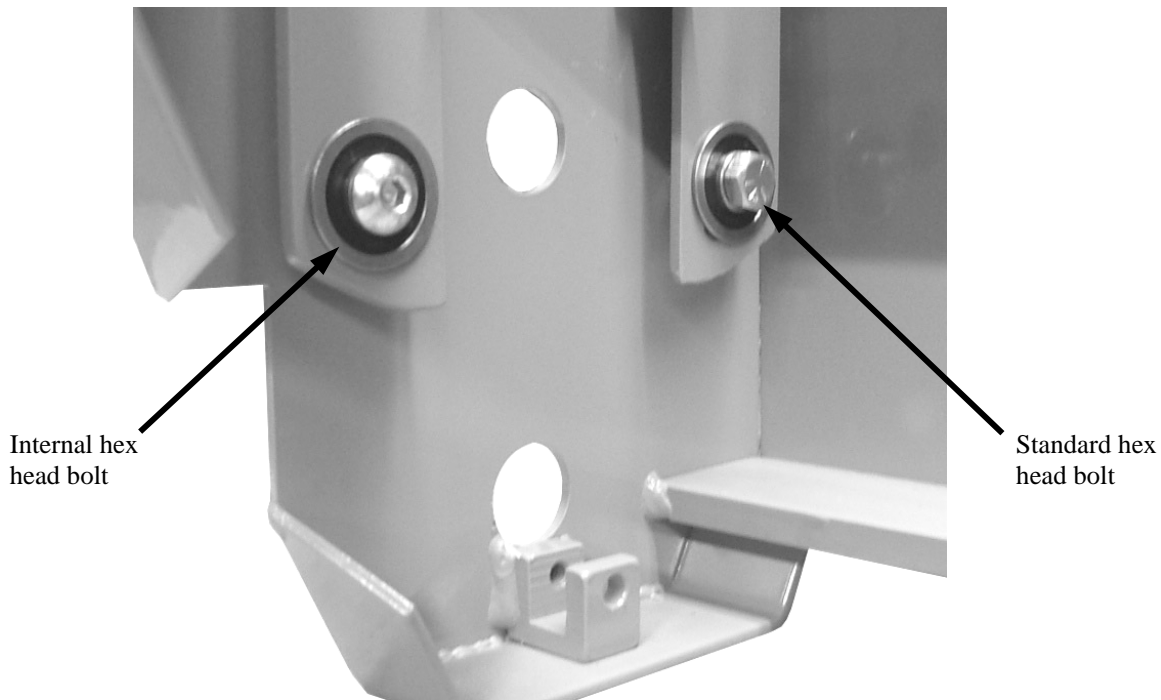

Figure 7-12. Bag Clamp Arm Bolts And Bearings Installed

5. Install and tighten the nuts on the bag clamp arm mounting bolts. Do not over tighten.
6. Install the bag clamp cylinders. Refer to 7.3.10 Bag Clamp Cylinder Replacement.
7. Install the bag clamp arm spring. Refer to 7.3.9 Bag Clamp Arm Spring Replacement.
8. Connect the chain links to the bag clamp pivot blocks.
9. Install the spout assembly on the TE100. Refer to the 7.3.1 Spout Replacement.
10. Connect the main electrical and pneumatic connections.
11. Turn the TE100 on and test for proper operation.

7.3.9 Bag Clamp Arm Spring Replacement

On each side of the TE100, a spring is used to connect the two bag clamp arms. Over time, the bag clamp arm springs may weaken or become damaged. Follow the steps below to replace the springs.

7.3.9.1 Bag Clamp Arm Spring Removal

1. Turn the TE100 off.
2. Disconnect the main electrical and pneumatic connections.
3. Remove the spout. Refer to 7.3.1 Spout Replacement.
4. Position the spout so that it is upside down on a workbench.
5. Remove the nuts from the bolts that connect the springs to the bag clamp arms. The nuts will be between the bag clamp arms and the spout.
6. Remove the springs and bolts.
7. Remove the bolts from the spring eyes.

7.3.9.2 Bag Clamp Arm Spring Installation

1. Insert the bolts through the spring eyes.
2. Insert the bolts through the spring mounting bolts in the bag clamp arms.
3. Install and tighten the nuts on the bolts.
4. Install the spout. Refer to 7.3.1 Spout Replacement.
5. Connect the main electrical and pneumatic connections.
6. Turn the TE100 on and test for proper operation.

7.3.10 Bag Clamp Cylinder Replacement

If one of the bag clamp cylinders develops a leak, or is receiving air pressure and fails to function, use the procedures below to replace it.

7.3.10.1 Bag Clamp Cylinder Removal

1. Turn the TE100 off.
2. Disconnect the main electrical and pneumatic connections.
3. Remove the spout. Refer to the 7.3.1 Spout Replacement.
4. Place the spout assembly on a workbench upside down.
5. Remove the bag clamp cylinder quick connect fittings. This is done from the outside of the spout.
6. Loosen the jam nut on the cylinder rod at the pivot block.
7. Make a mark, using a permanent marker, on the cylinder rod.
8. Rotate the rod to back it out of the pivot block threads. Count the number of rotations until the rod is free of the pivot block.
9. Loosen and remove the cylinder mounting bolt.
10. Remove the cylinder.

7.3.10.2 Bag Clamp Cylinder Installation

1. Make a mark on the cylinder rod of the cylinder, near the threads.
2. Make sure that there is a jam nut on the threaded end of the rod. Make sure that the jam nut is turned all the way onto the rod.
3. Position the bag clamp cylinder with the mounting tab in the mounting bracket inside the scale cabinet. Also, make sure that the two pneumatic ports are visible through the port holes in the scale cabinet.
4. Install and tighten the cylinder mounting bolt.
5. Insert the tip of the rod into the pivot block.
6. Start threading the rod into the pivot block. Count the number of rotations. Stop when the number of rotations equals the number of rotations counted in the removal procedure.
7. Tighten the jam nut against the pivot block.
8. Install the two pneumatic quick connect fittings into the ports on the cylinder. Refer to 7.3.13 Pneumatic Quick Connect Fitting Replacement
9. Install the spout. Refer to the 7.3.1 Spout Replacement.
10. Connect the main electrical and pneumatic connections.
11. Turn the TE100 on and test for proper operation.

7.3.11 Bag Clamp Pivot Block Replacement

If one of the bag clamp pivot blocks becomes damaged or worn, or is receiving air pressure and fails to function, use the procedures below to replace it.

7.3.11.1 Bag Clamp Pivot Block Removal

1. Turn the TE100 off.
2. Disconnect the main electrical and pneumatic connections.
3. Remove the spout. Refer to the 7.3.1 Spout Replacement.
4. Place the spout assembly on a workbench upside down.
5. Remove the chain link clip from both chain links attached to the pivot block.
6. Loosen the jam nut on the cylinder rod at the pivot block.
7. Make a mark, using a permanent marker, on the cylinder rod.
8. Rotate the rod to back it out of the pivot block threads. Count the number of rotations until the rod is free of the pivot block.

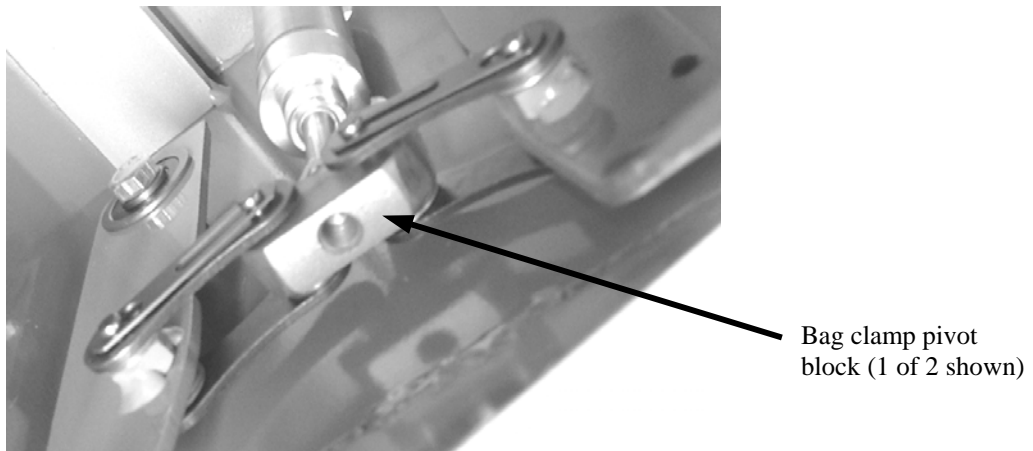

Figure 7-13. Bag Clamp Pivot Block

7.3.11.2 Bag Clamp Pivot Block Installation

1. Position the pivot block. Slide the pivot block over the chain link pins.
2. Start threading the rod into the pivot block. Count the number of rotations. Stop when the number of rotations equals the number of rotations counted in the removal procedure.
3. Tighten the jam nut against the pivot block.
4. Install the chain link clip.
5. Install the spout. Refer to the 7.3.1 Spout Replacement.
6. Connect the main electrical and pneumatic connections.
7. Turn the TE100 on and test for proper operation.

7.3.12 Air Supply Line Replacement

In the event that an air supply line becomes damaged and requires replacement, use the following procedures to replace the air supply line.

7.3.12.1 Air Supply Line Removal

1. Turn the TE100 off.
2. Disconnect the main electrical and pneumatic connections.
3. Remove any clips and/or retainers that hold the air supply lines in place.
4. Remove the air supply line, making note of how the line is routed.
5. Measure the air supply line that was just removed.
6. Cut a new length of air supply line, making sure that the ends of the line are cut square. Cut the new line to the same length of the one that was removed.

7.3.12.2 Air Supply Line Installation

1. Route the new air supply line in the same manner as the one that was removed.
2. Insert each end of the new line into their fittings.
3. Reattach any clips and/or retainers to secure the air supply line.
4. Reconnect the main pneumatic connection and check for any leaks. If a leak is found, disconnect the main pneumatic connection and then disconnect/reconnect the air connections, then reconnect the main pneumatic connection. Repeat as necessary, until no leaks are present.
5. Reconnect the main power cord.

7.3.13 Pneumatic Quick Connect Fitting Replacement

In the event that a quick connect fitting becomes damaged and requires replacement, use the following procedures to replace the quick connect fitting.

7.3.13.1 Pneumatic Quick Connect Fitting Removal

1. Turn the TE100 off.
2. Disconnect the main electrical and pneumatic connections.
3. Disconnect the air supply line from the fitting by pressing in on the collar while pulling out on the air supply line.
4. Using a wrench, unscrew the fitting.

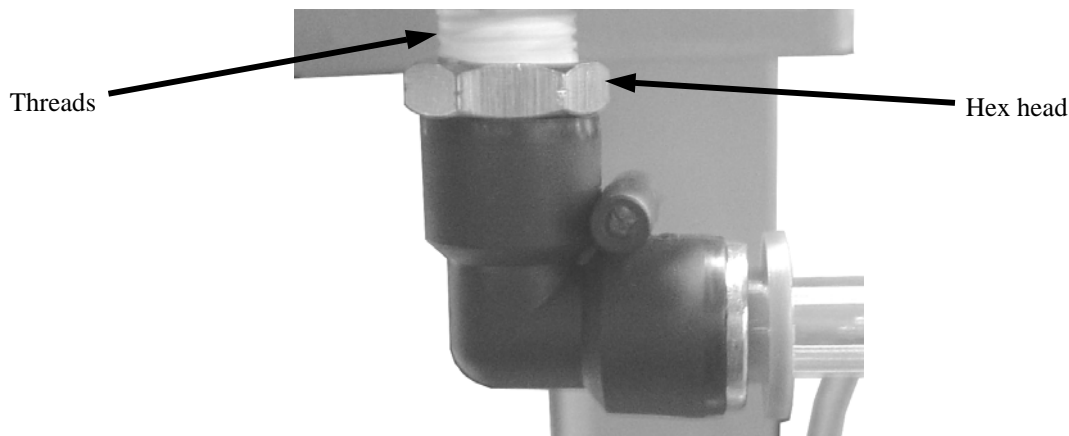

Figure 7-14. Air Supply Fitting

7.3.13.2 Pneumatic Quick Connect Fitting Installation

1. Using Teflon[®] tape, wrap the threads of the new fitting, starting at the bottom of the thread working toward the hex head in the same direction as the threads.
2. Screw the new fitting into the threads and use a wrench to carefully tighten the fitting.



CAUTION

Over tightening the fitting can damage the fitting, or the component that it is being threaded into.

3. Reconnect the air supply line to the fitting.
4. Reconnect the main pneumatic connection and check for any leaks. If a leak is found, disconnect the main pneumatic connection and then disconnect/reconnect the air connections, then reconnect the main pneumatic connection. Repeat as necessary, until no leaks are present.
5. Reconnect the main electrical connection.
6. Turn the TE100 on and test for proper operation.

Glossary

TERM	DEFINITION
AC	Alternating Current
Bag clamp arms	Actuated by two pneumatic cylinders, these arms press the bag outward against two rubberized pads that are attached to the spout. When applied, the two bag clamp arms work with the bag clamp pads to hold the bag in place while it is being filled.
Bag clamp pads	A set of two rubber pads is mounted to the bottom of the spout. When the bag clamp arms are actuated, two bag clamp pads work with the bag clamp arms to hold the bag in place while it is being filled.
Bag position switch	Mounted on the bottom of the spout, this switch will prevent the fill cycle from starting if a bag is not in place.
Bagging cycle	A series of functions that describe the packaging process, from beginning to end, for one package of product.
Component	An item of hardware as commonly supplied complete by manufacturers.
Cubic Feet/Minute (CFM)	A unit of measure that is used to describe the amount of compressed air that is used by a machine.
DC	Direct Current
De-energize	To deprive an electro-receptive device of its operating current.
Dribble gate	A metal gate that is used to restrict the flow of product. A pneumatic cylinder actuates the gate. When the weight of the package reaches the dribble weight, the cylinder extends, moving the gate to partially obstruct the flow of product.
ESD	Electrostatic Discharge
Ground	Ground (Electrical). A conducting connection, whether intentional or accidental, between an electrical circuit or equipment and the earth, or some other conducting body at a reference potential.
kg	Kilogram
lb or lbs	Pound or pounds
Load cell	An electronic device that is used to monitor the weight of the product that is being packaged.
MAC valve	A device that combines an electric solenoid and a pneumatic valve. Voltage is applied or removed from the solenoid to cause the pneumatic valve to move. Used to control the pneumatic cylinders.
Product	Refers to the material that is being packaged by the machine.
Shut off gate	A hinged metal gate that is actuated by a pneumatic cylinder to start and stop the fill cycle. The shut off gate is opened when a bag is in place and the operator trips the lever on the start switch. The gate is closed according to the settings made by the operator in the control panel.
Spout	A component whose primary function is to guide the product from the feed mechanism into the package. The spout also serves as the mounting point for several other components.
Start switch	An electronic switch that is mounted toward the bottom of the spout. The switch has a wire bale that is attached to the rotary switch. When the operator trips the switch, the fill cycle starts.
Surge	A sudden rise of current or voltage.
Surge Hopper	A reservoir where product is stored for packaging.
T4000	An electronic control panel that was jointly developed by Taylor Products and Hardy Instruments. This control panel is standard control panel on the TE100.

This Page Intentionally Left Blank

Index

<p>Air Supply Line Replacement, 7-15</p> <p>Bag Clamp Adjustment, 7-1</p> <p>Bag Clamp Arm Replacement, 7-10</p> <p>Bag Clamp Arm Spring Replacement, 7-12</p> <p>Bag Clamp Arms, 1-8</p> <p>Bag Clamp Cylinder Replacement, 7-13</p> <p>Bag Clamp Cylinders, 1-9</p> <p>Bag Clamp Pads, 1-9</p> <p>Bag Clamp Pivot Block Replacement, 7-14</p> <p>Bag Position Switch, 1-10</p> <p>Calibrating the T4000 Control Panel, 3-10</p> <p>Calibration, 3-7</p> <p>Check All Fasteners, 5-1</p> <p>Check Calibration, 5-1</p> <p>Cleaning, 5-1</p> <p>Control Box, 1-6</p> <p>Daily Maintenance Procedures, 5-1</p> <p>Dribble Gate, 1-4</p> <p>Dribble Gate Cylinder, 1-4</p> <p>Dribble Gate Cylinder Replacement, 7-7</p> <p>Dribble Gate Mounting Rails, 1-4</p> <p>Dribble Gate Replacement, 7-7</p> <p>Dribble Gate Setup, 3-13</p> <p>Dry Cycle, 3-7</p> <p>Electrical Connections, 3-3</p> <p>Electrical Requirements, 1-1</p> <p>Electro-static Discharge (ESD) Prevention Procedures, ii</p> <p>Field Service, iii</p> <p>Filter/Regulator/Lubricator (FRL) Assembly, 1-6</p> <p>Glossary, 7-1</p> <p>Initial Setup, 4-12</p> <p>Installing the Optional Small Bag Adapter, 3-15</p> <p>Introduction, 1-1</p> <p>Load Cell, 1-4</p> <p>Load Cell Connections, 3-6</p> <p>Load Cell Replacement, 7-6</p> <p>Lubrication Requirements, 3-6</p> <p>MAC Valve Flow Control Adjustment, 7-3</p> <p>MAC Valves, 1-5</p> <p>Maintaining Operational Efficiency, 4-13</p> <p>Major Systems and Components, 1-2</p>	<p>Making Electrical Connections, 3-3</p> <p>Making Pneumatic Connections, 3-6</p> <p>Manual Scope, 1-1</p> <p>Mechanical Setup, 3-2</p> <p>Monthly Maintenance, 5-1</p> <p>Normal Operation (Typical Fill Cycle), 4-13</p> <p>Operation, 4-1</p> <p>Operational Controls, 4-1</p> <p>Optional Small Bag Adapter, 1-11</p> <p>Pneumatic Quick Connect Fitting Replacement, 7-15</p> <p>Pneumatic Requirements, 1-1</p> <p>Pre-Calibration Mechanical Checks, 3-9</p> <p>Preventive Maintenance, 5-1</p> <p>Product Description, 1-1</p> <p>Receiving Equipment, 2-1</p> <p>Repair and Adjustment, 7-1</p> <p>Scale Cabinet, 1-3</p> <p>Scale Cabinet Assembly, 1-3</p> <p>Setting Auto Adjust Cutoff, 3-14</p> <p>Setting the Auto Adjust Limit, 3-14</p> <p>Setup/Installation, 3-1</p> <p>Shut Off Gate, 1-4</p> <p>Shut Off Gate Adjustment, 7-2</p> <p>Shut Off Gate Bearings, 1-4</p> <p>Shut Off Gate Cylinder, 1-4</p> <p>Shut Off Gate Cylinder Replacement, 7-8</p> <p>Shut off Gate Replacement, 7-8</p> <p>Shut Off Gate Seal Replacement, 7-10</p> <p>Spout, 1-7</p> <p>Spout assembly, 1-7</p> <p>Spout Replacement, 7-4</p> <p>Start Switch, 1-10</p> <p>System Adjustments, 7-1</p> <p>System Repairs, 7-4</p> <p>T4000 Menu System, 4-4</p> <p>Trouble Symptoms, 6-1</p> <p>Troubleshooting, 6-1</p> <p>Troubleshooting Process, 6-1</p> <p>Turning Auto Adjust Cutoff On/Off, 3-14</p> <p>Uncrating the Equipment, 2-1</p> <p>Warranty Information, iii</p>
-------------------------------------------------------------------------------------------------------------------------------------------------------------------------------------------------------------------------------------------------------------------------------------------------------------------------------------------------------------------------------------------------------------------------------------------------------------------------------------------------------------------------------------------------------------------------------------------------------------------------------------------------------------------------------------------------------------------------------------------------------------------------------------------------------------------------------------------------------------------------------------------------------------------------------------------------------------------------------------------------------------------------------------------------------------------------------------------------------------------------------------------------------------------------------------------------------------------------------------------------------------------------------------------------------------------------------------------------------------------------------------------------------------------------------------------------------------------------------------------------------------------------------------------------------------------------------------------------------------------------------------------------------------------------------------------------------------------------------------------------------------------------------------------------------------------	------------------------------------------------------------------------------------------------------------------------------------------------------------------------------------------------------------------------------------------------------------------------------------------------------------------------------------------------------------------------------------------------------------------------------------------------------------------------------------------------------------------------------------------------------------------------------------------------------------------------------------------------------------------------------------------------------------------------------------------------------------------------------------------------------------------------------------------------------------------------------------------------------------------------------------------------------------------------------------------------------------------------------------------------------------------------------------------------------------------------------------------------------------------------------------------------------------------------------------------------------------------------------------------------------------------------------------------------------------------------------------------------------------------------------------------------------------------------------------------------------------------------------------------------------------------------------------------------------------------------------------------------------------------------------------------------------------------------------------------------------------------

This Page Intentionally Left Blank

Appendix A

Safety Procedures, Cautions, Warnings, and Notices

- General safety precautions must be observed during all phases of operation, service and repair of the TE100. Failure to comply with these precautions or with specific warnings elsewhere in this manual violates safety standards of design, manufacture and intended use of the TE100.
- The manufacturer assumes no liability for customer's failure to comply with the following requirements:
- Qualified technicians and maintenance personnel should service the equipment described in this manual.
- Do not attempt internal service or adjustments unless another person, capable of rendering first aid and resuscitation, is available.
- Do not substitute parts or modify equipment. This practice could, in some cases, introduce the danger of additional hazards
- The TE100 contains some electrostatic-sensitive components. Therefore, always ground yourself with a proper wrist strap before handling any modules or printed circuit boards so that static charges are removed from the person. Use static suppressive packaging to protect electronic assemblies removed from the TE100.
- Observe all procedural cautions and warnings located on the equipment and throughout this manual.
- Read and follow all instructions
- Follow all warnings and instructions marked on the units and listed in manuals.

This Page Intentionally Left Blank

Appendix B Spare Parts

Table B-1. TE100 Spare Parts List

	Part Description	Part Number
1	Humphrey gate cylinder (1.0625" bore, 2.5" stroke, 5/16-24 rod, bumper)	50-1184
2	Humphrey clamp cylinder (1.0625" bore, 1.5" stroke, 5/16-24 rod)	50-1166
3	Gate slide bearing	50-7057
4	MAC solenoid valve (less manifold base)	53-0276
5	Gate and clamp bearings (3/8" bore, flanged)	50-7011
6	Bronze gate cylinder clevis bushing (1/4"X5/16"X1/4")	50-7098
7	200lb. load cell (platform type, stainless steel)	50-1549
8	Bag clamp pads	60-0185 & 604 1/2 X 3 (set)
9	Bag clamp extension spring (7/16" X 2-15/16"	53-2007
10	Potentiometer (1K, 10 turn meter)	50-1721

This Page Intentionally Left Blank

Appendix C Mechanical Drawings

Table C-2. TE100 Mechanical Drawings

	Drawing Title	Dwg Number
1	TE-100 T4000	TE-100 T4000-1-101-00.dwg
2	TE100 Exploded View	ISO-1.dwg
3	TE-100 Exploded View Bill of Materials	ISO-1 BOM.dwg
4	TE100 Bag Clamp Arms & Related Components – Exploded View	ISO-2.dwg
5	TE-100 Bag Clamp Arms & Related Components – Exploded View Bill of Materials	ISO-2 BOM.dwg
6	TE100 Spout Assembly – Exploded View	ISO-3.dwg
7	TE-100 Spout Assembly – Exploded View Bill of Materials	ISO-3 BOM.dwg
8	TE100 Scale Cabinet – Exploded View	ISO-4.dwg
9	TE100 Scale Cabinet – Exploded View Bill of Materials	ISO-4 BOM.dwg
10		
11		
12		
13		
14		
15		
16		
17		
18		

This Page Intentionally Left Blank

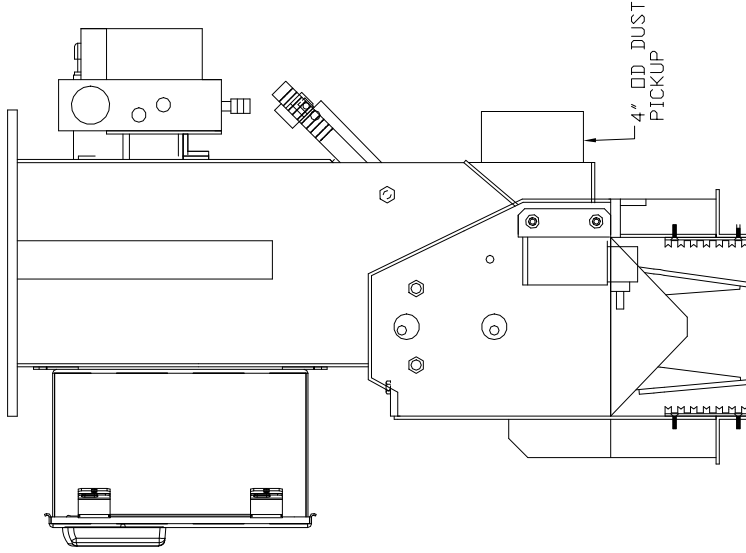
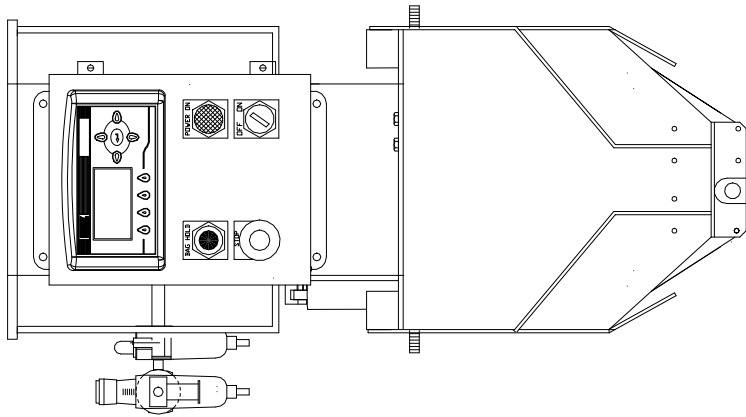

MODEL: TE-100 T4000
 VIEW.:
 SCALE: 1/8 TP #:
 DRAWN BY: _____ CHECKED BY: _____
 P.O. #:
 ORDER # _____ PG:1 OF:1

CUSTOMER NAME: _____
 CUSTOMER TAG #: _____
 DRAWING DATE: 12/14/07
 REVISED BY: _____ EGN #:
 DRAWING NAME: TE-100 T4000-1-101-00
 LAST 2 DIGITS IN DRAWING NAME INDICATE REVISION NUMBER

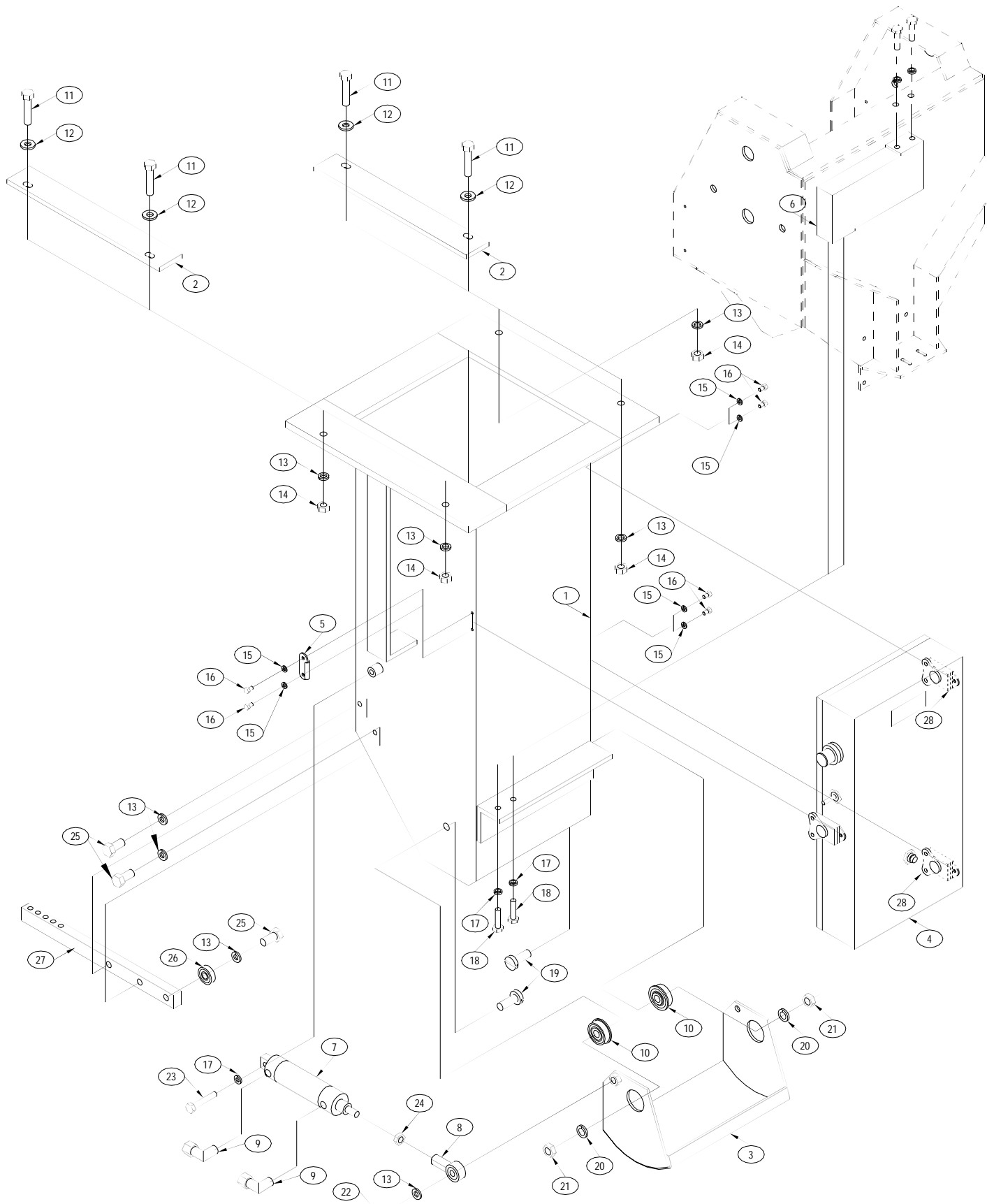

NUMBERS MAY REFERENCE 60 or 65 TAYLOR STOCK PARTS
 w/SOME EXCEPTIONS
 60 NUMBERS REFERENCE STEEL PARTS
 65 NUMBERS REFERENCE STAINLESS STEEL PARTS

Machine Type: TE100
 Dwg Name: ISO-1.dwg
 Dwg View: Exploded View

I T E M	Q T Y	PART NUMBER	TE-100 ISO-1 BILL OF MATERIALS
			DESCRIPTION
1	1	60-0145	MAIN CABINET
2	2	60-0275	MOUNTING STRAPS
3	1	60-0147	MAIN CUT OFF GATE
4	1	50-1645	METER WEIGHING DUAL SET POINT
5	1		FASTENER & KEEPER PLATE
6	1	50-1549	LOAD CELL, 200# PLATFORM TYPE SS
7	1	50-1164	CYLINDER HUMPHERY 1.0625" BORE 2.5" STROKE
8	1	50-7055	BEARING ROD END BEARING 5/16-24
9	2		1/4" HOSE X 1/8" NPT CONNECTOR ELL
10	2	50-7011	3/8" BORE 1 1/8"OD FLANGE BEARING
11	4		5/16"-18 X 1 1/2" HEX HEAD
12	4		5/16" FLAT WASHER
13	5		5/16" LOCK WASHER
14	4		5/16"-18 HEX NUT
15	6		#8 LOCK WASHER
16	6		8-32 X 3/8" HEX HEAD
17	2		1/4" LOCK WASHER
18	2		1/4"-28 X 1" HEX HEAD
19	2		3/8"-16 X 3/4" ROUND HEAD
20	2		3/8" LOCK WASHER
21	2		3/8"-16 JAM NUT
22	1		5/16"-18 X 3/4" BUTTON HEAD
23	1		1/4"-20 X 1 1/2" HEX HEAD
24	1		5/16"-24 JAM NUT
25	4		5/16"-18 X 3/4" HEX HEAD
26	2	50-7057	SCALE BEAM BEARING 38KDD
27	2	60-0188	DRIBBLE GATE MOUNTING RAIL
28	2		HINGE

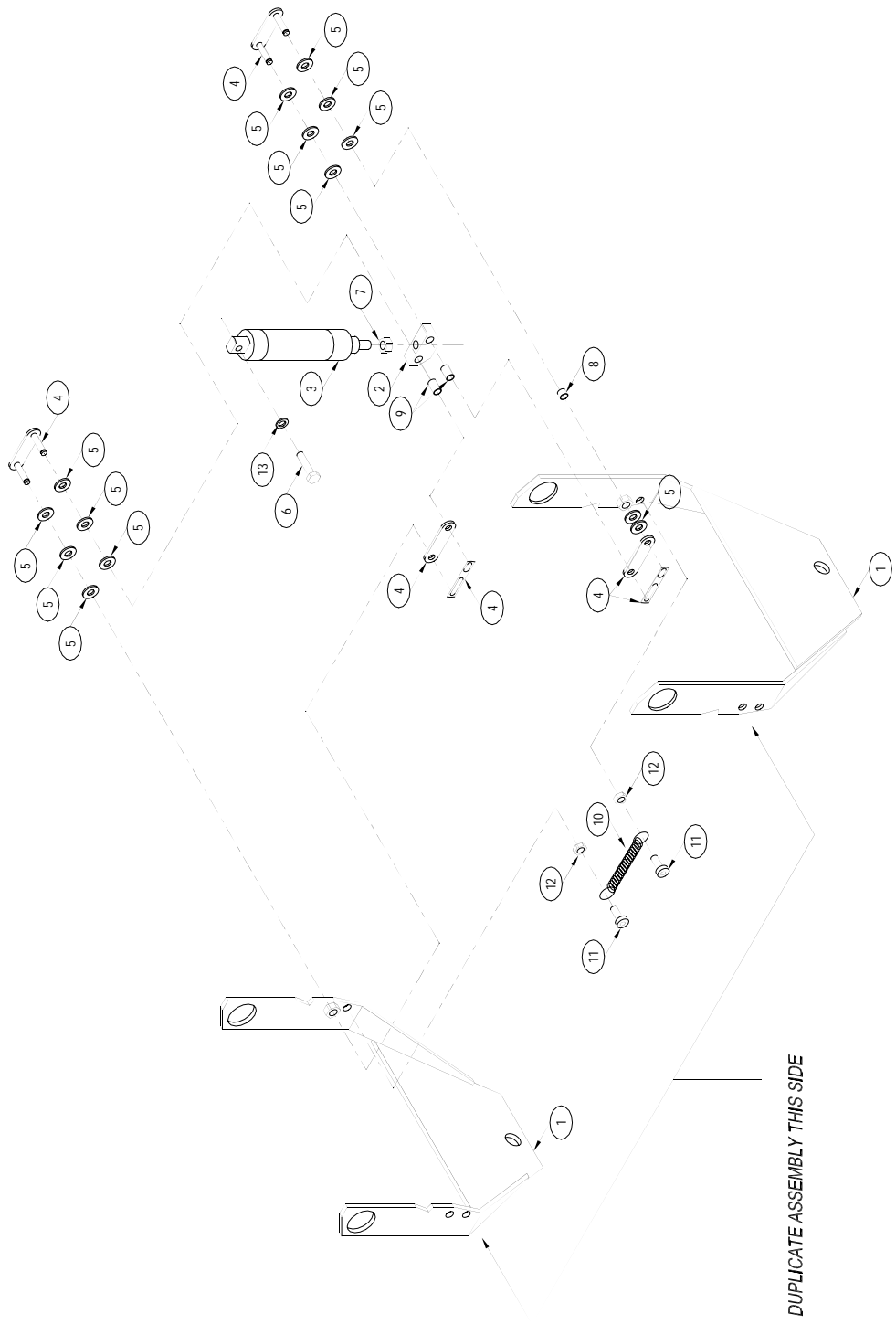

DUPLICATE ASSEMBLY THIS SIDE

NUMBERS MAY REFERENCE 60 or 65 TAYLOR STOCK PARTS
 w/SOME EXCEPTIONS
 60 NUMBERS REFERENCE STEEL PARTS
 65 NUMBERS REFERENCE STAINLESS STEEL PARTS

Machine Type: TE100
 Dwg Name: ISO-2.dwg
 Dwg View: Bag Clamp Arms & Related Components - Exploded View

I T E M	Q T Y	PART NUMBER	TE-100 ISO-2 BILL OF MATERIALS
			DESCRIPTION
1	2	60-0171	BAG CLAMP ARM
2	2	60-0172	CLAMP ARM PIVOT BAR
3	2	50-1166	CYLINDER, HUMPHERY, 1.0625" BORE 1.5
4	4	50-7505	CHAIN ROLLER TAB ASSEMBLY EARS
5	32		1/4" FLAT WASHER SS
6	2		1/4"-20 X 1 1/2" HEX HEAD
7	2		5/16"-24 X JAM NUT
8	4	50-7098	BUSHING BRONZE 1/4" X 5/16" X 1/4"
9	2	50-7097	BUSHING BRONZE 1/4" X 5/16" X 1/2"
10	2	53-2007	TE-100 BAG CLAMP SPRING
11	4		1/4"-20 X 3/4" ALLEN HEAD
12	4		1/4"-20 HEX HEAD
13	2		1/4" LOCK WASHER

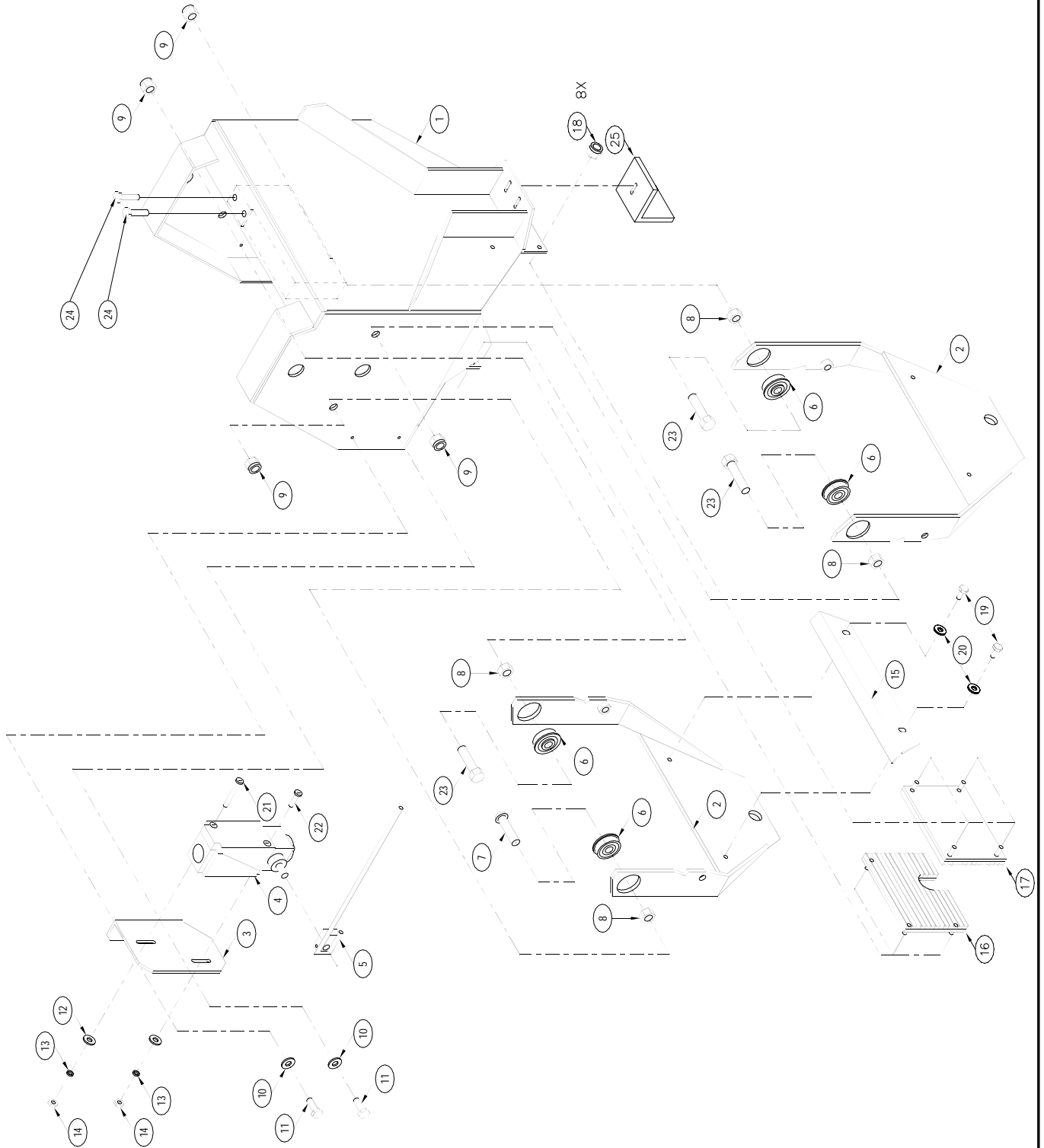

NUMBERS MAY REFERENCE 60 or 65 TAYLOR STOCK PARTS
 w/SOME EXCEPTIONS
 60 NUMBERS REFERENCE STEEL PARTS
 65 NUMBERS REFERENCE STAINLESS STEEL PARTS

Machine Type: TE100
 Dwg Name: ISO-3.dwg
 Dwg View: Spout Assembly - Exploded View

I T E M	Q T Y	PART NUMBER	TE-100 ISO-3 BILL OF MATERIALS
			DESCRIPTION
1	1	60-0173	SPOUT HOUSING
2	2	60-0171	BAG CLAMP ARM
3	1	60-0176	START SWITCH BRACKET
4	1	50-1017	LIMIT SWITCH NEMA 4,13 SINGLE POLE
5	1	50-7424	SWITCH LEVER 8 1/2" LONG FOR 802T
6	4	50-7011	BEARING 3/8" BORE 1 1/8" OD
7	1		3/8"-16 X 1 1/2" HEX HEAD
8	4		3/8"-16 HEX NUT
9	4		3/8"-16 NYLON LOCK NUT
10	2		1/4" LOCK WASHER
11	2		1/4"-20 X 1/2" HEX HEAD
12	2		10 FLAT WASHER
13	2		10 LOCK WASHER
14	2		10-32 HEX NUT
15	1	60-1061	REAR DEFLECTOR
16	1	60-0185	BAG CLAMP PAD W/ SLOT
17	1	60-0739	BAG CLAMP PAD W/O SLOT
18	8		10-32 NYLON LOCK NUT
19	2		1/4"-20 X 1/4" ALLEN BUTTON HEAD
20	2		1/4" FLAT WASHER SS
21	1		10-32 X 1 1/2" SLOT HEAD
22	1		10-32 X 3/4" SLOT HEAD
23	3		3/8-16 x 1 1/2 HEX HEAD
24	2		1/4-28 X 1 HEX HEAD
25	1	60-0187	SHIPPING BRKT

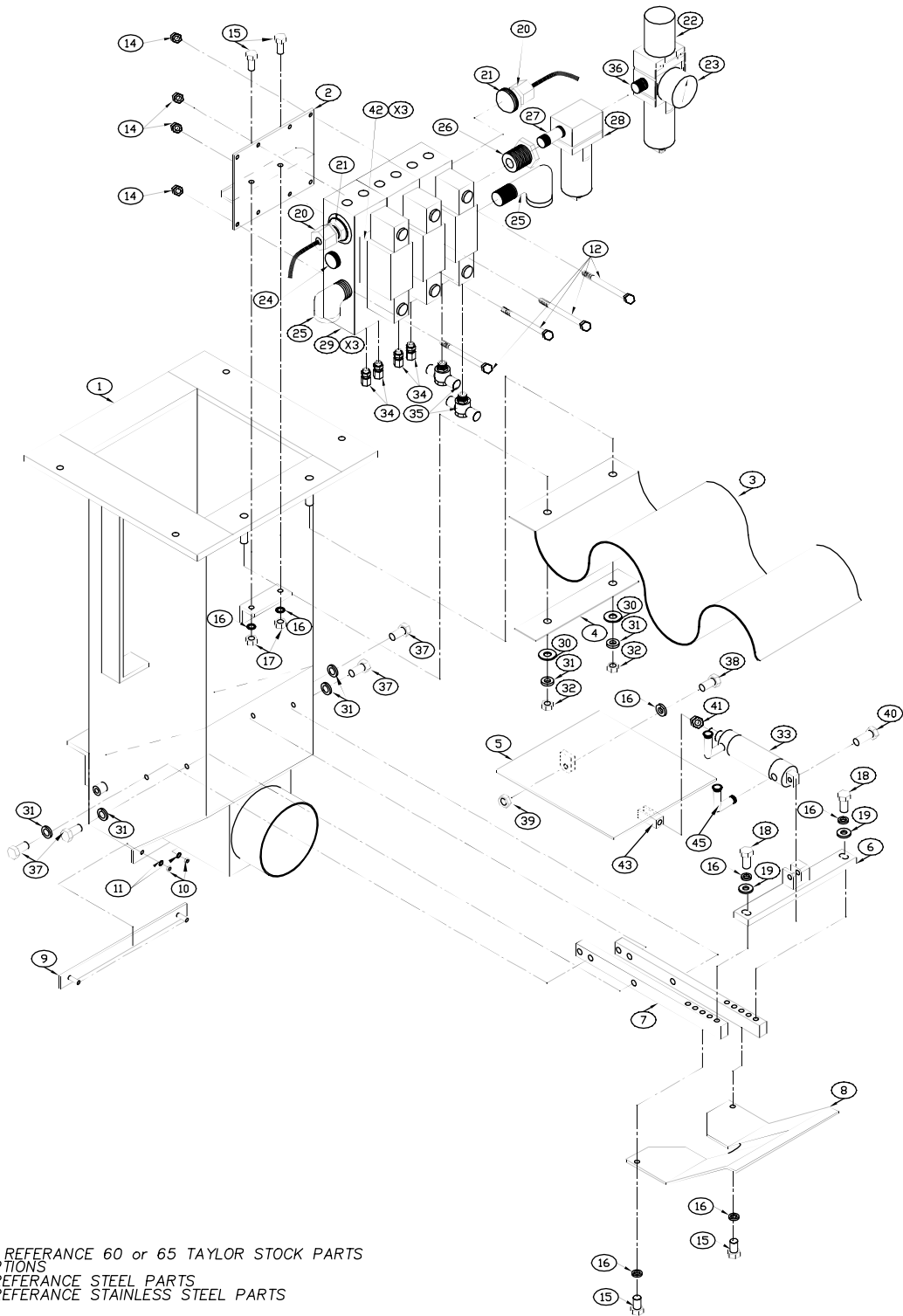

NUMBERS MAY REFERANCE 60 or 65 TAYLOR STOCK PARTS
 w/SOME EXCEPTIONS
 60 NUMBERS REFERANCE STEEL PARTS
 65 NUMBERS REFERANCE STAINLESS STEEL PARTS

Machine Type: TE100
 Dwg Name: ISO-4.dwg
 Dwg View: Scale Cabinet - Exploded View

ITEM		TE-100 ISO-4 BILL OF MATERIALS	
QTY	PART NUMBER	DESCRIPTION	
1	60-0145	MAIN CABINET	
2	60-0470	VALVE MOUNT ASSEMBLY	
3	60-0186	MAIN CABINET RUBBER SKIRT	
4	60-0189	RUBBER MOUNTING STRAP	
5	60-0174	DRIBBLE GATE	
6	60-0175	DRIBBLE GATE CYLINDER MTG BRKT	
7	60-0188	DRIBBLE GATE MOUNTING RAILS	
8	60-0430	BACK COVER	
9	60-0197	S/S CUTOFF STRAP	
10		#8-32 NYLON LOCK NUT	
12		#10-32 X 2 1/2" CAP SOCKET HEAD SCREW	
13		#10 LOCK WASHER	
14		#10-32 HEX NUT	
15		1/4"-20 X 3/4" HEX HEAD BOLT	
16		1/4" LOCK WASHER	
17		1/4"-20 HEX NUT	
18		1/4"-20 X 3/4" HEX HEAD BOLT	
19		1/4" FLAT WASHER	
20		STRAIN RELIEF 1/2" NPT X 25--375	
21		1 1/4" NPT X 1/2" NPT BUSHING	
22	50-1712	FILTER / REGULATOR	
23	50-0322	0-200 PSI GAUGE 1/8" NPT	
24		3/8" NPT GALVANIZED PLUG	
25		3/8" NPT X 90 STREET ELL	
26		3/8" NPT X 1/4" NPT REDUCER BUSHING	
27		1/4" NPT X 2 1/2" NIPPLE	
28	50-1713	1/4" NPT OILER	
29	53-1904	MAC SOLENOID VALVE	
30		5/16" FLAT WASHER	
31		5/16" LOCK WASHER	
32		5/16" - 18 HEX NUT	
33	50-1164	CYLINDER 1.0625 BORE X 2.5 STROKE	
34		MALE CONNECTOR 1/4" TUBE X 1/4" NPT	
35		MALE CONNECTOR TEE 1/4" TUBE X 1/4" NPT	
36		1/4" NPT CLOSE NIPPLE	
37		5/16"-18 X 3/4" HEX HEAD	
38		1/4"-20 X 1 1/4" HEX HEAD SS	
39	50-1164	1/4"-20 NYLOCK HEX NUT	
40		1/4"-20 X 1 1/2" HEX HEAD	
41		5/16"-24 JAM NUT	
42	53-0291	FLOW CONTROL VALVE	

ITEM		TE-100 ISO-4 BILL OF MATERIALS	
QTY	PART NUMBER	DESCRIPTION	
43	50-7176	CLEVIS 5/16-24	
44	60-0187	SHIPPING BRACKET (NOT SHOWN)	
45		1/4 HOSE X 1/8 NPT CONNECTOR ELL	

This Page Intentionally Left Blank

Appendix D Electrical Drawings

Table D-3. TE100 Electrical Drawings

	Drawing Title	Part Number
1	TE-100 Outside Enclosure	TE100-1-401-00.dwg
2	TE-100 Subpanel Layout	TE100-1-402-00.dwg
3	TE-100 Schematic	TE100-1-403-00.dwg
4	TE-100 Schematic	TE100-1-404-00.dwg
5	TE-100 T4000 Pneumatic	TE100-1-500-00.dwg
6	TE-100BIP	TE1002BIP.dwg
7		
8		
9		
10		

This Page Intentionally Left Blank

BILL OF MATERIALS

ITEM	QTY	PART NUMBER	DESCRIPTION
1	1	50-7710	T4000 METER
2	1	50-1036	SWITCH,PANEL,NEMA 12,4,BLACK FLUSH
3	1	50-1406	POWER ON INDICATOR LAMP
3	1	50-1408	GREEN LENS CAP FOR POWER LAMP
4	1	50-1035	POWER OFF-ON SELECTOR SWITCH
5	1	50-1415	STOP PUSH-PULL SWITCH
5	1	50-1413	MUSHROOM HEAD FOR STOP SWITCH
6	1	50-1055	CONTROL BOX 8 X 10

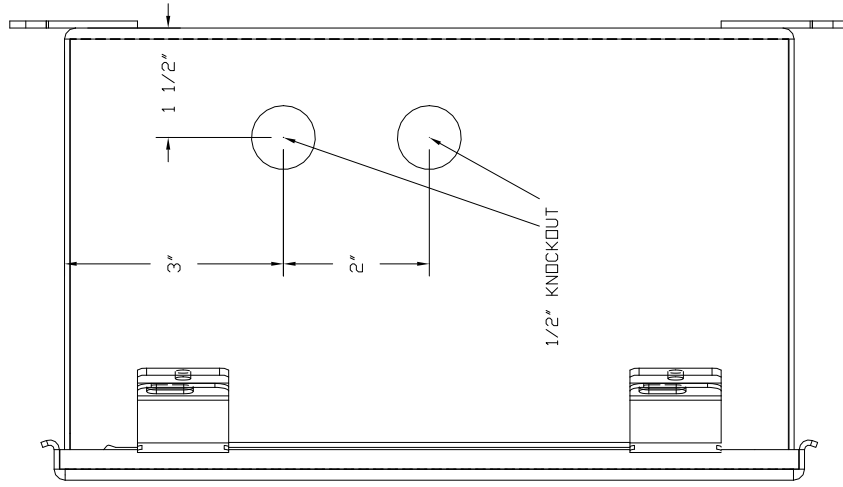
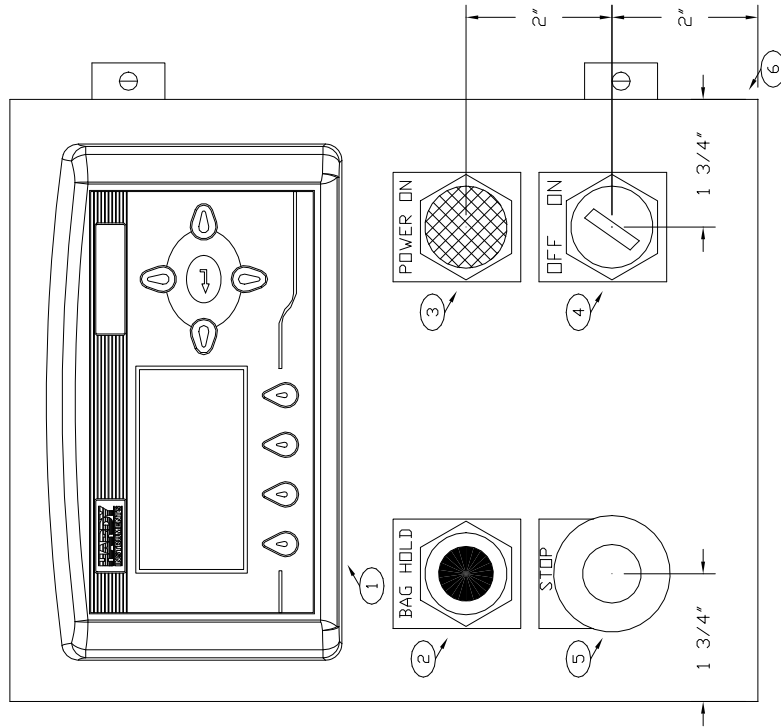
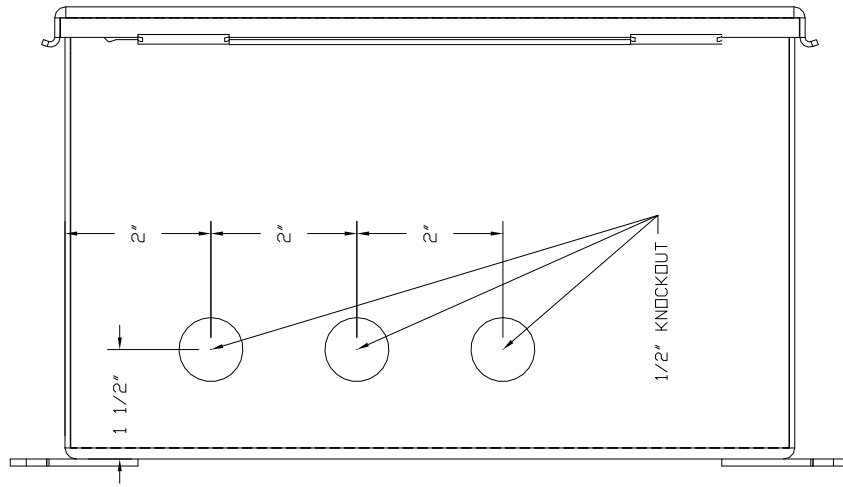

MODEL: TE-100	CUSTOMER NAME: TE-100
VIEW: OUTSIDE ENCLOSURE	CUSTOMER TAG #:
SCALE: 3/8" TP #:	DRAWING DATE: 07/23/07
DRAWN BY: CS	REVISED BY: ECN #:
P.O. #:	DRAWING NAME: TE100-1-401-00
ORDER #:	LAST 2 DIGITS IN DRAWING NAME INDICATE REVISION NUMBER
PG: 1	OF: 4

ITEM	QTY	PART NUMBER	DESCRIPTION
1	3	50-7706	TERMINAL RELAY DC COIL
2	2	50-1744	FUSE HOLDER, RAIL TYPE WITH NEON
3	15	50-1813	TERMINAL BLOCK, UNIVERSAL RAIL TYPE
4	1	53-0025	PANEL, A-10P8

BILL OF MATERIALS

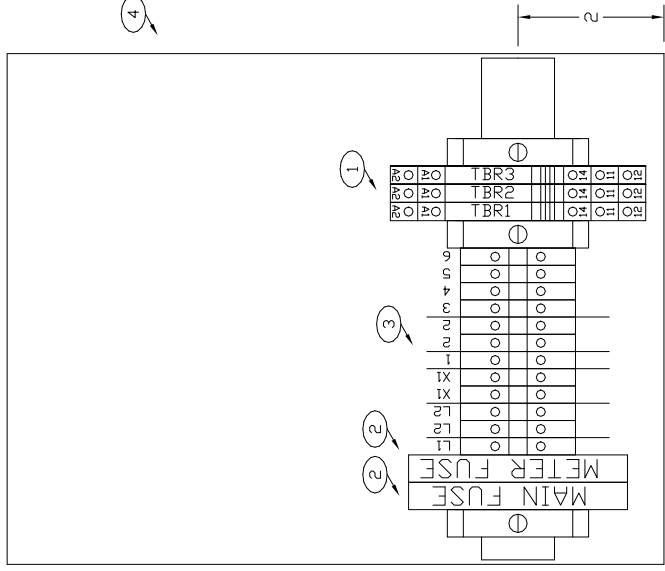

MODEL: TE-100	CUSTOMER NAME: TE-100
VIEW: SUBPANEL LAYOUT	CUSTOMER TAG #:
SCALE: 3/8" TP #:	DRAWING DATE: 07/23/07
DRAWN BY: CS	REVISOR BY: ECN #:
P.O. #:	DRAWING NAME: TE100-1-402-00
ORDER #:	LAST 2 DIGITS IN DRAWING NAME INDICATE REVISION NUMBER
PG: 2	OF: 4

ITEM	QTY	PART NUMBER	DESCRIPTION
1	1	50-7710	T-4000 WEIGH METER
2	3	50-7706	TERMINAL RELAY DC COIL

BILL OF MATERIALS

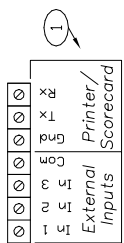

* CONTACT CLOSURE STYLE INPUTS

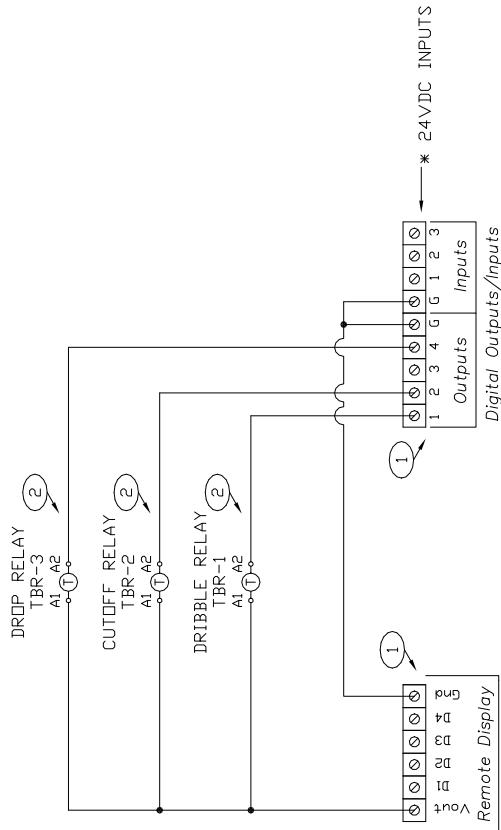

* NOTE:
CONTACT CLOSURE AND VOLTAGE INPUTS WORK THE SAME
INPUT 1 - ZERO INPUT
INPUT 2 - HOLD HIGH INPUT
INPUT 3 - NOT USED

OUTPUT 1 - SP1
OUTPUT 2 - SP2
OUTPUT 3 - SP3
OUTPUT 4 - START

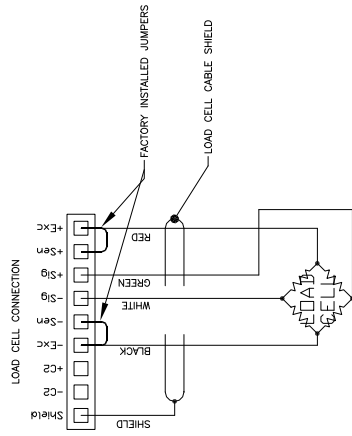

SENSOR INPUT TERMINATIONS

OPTION LC (SINGLE LOAD CELL OR SUMMED CONNECTION FROM JUNCTION BOX)

- NOTES:
- DO NOT RUN LOAD CELL CABLE PARALLEL TO, OR IN THE SAME CONDUIT WITH POWER WIRING, RELAY CABLE OR OTHER HIGH ENERGY CABLES.
 - FACTORY INSTALLED JUMPERS TO REMAIN IN PLACE FOR EDU/ VIRE LOAD CELL CONNECTION. JUMPERS TO BE REMOVED FOR SIX WIRE OR EIGHT WIRE (G2) LOAD CELL CONNECTIONS. EXCITATION AND SENSE WIRES TO BE CONNECTED TOGETHER IN JUNCTION BOX.
 - WIRE SIZE: 12 AWG MAXIMUM / 22 AWG MINIMUM



MODEL: TE-100	CUSTOMER NAME: TE-100
VIEW: SCHEMATIC	CUSTOMER TAG #:
SCALE: 3/8" TP #:	DRAWING DATE: 7/23/07
DRAWN BY: CS	REVISOR BY: ECN #:
P.O. #:	DRAWING NAME: TE100-1-404-00
ORDER #:	LAST 2 DIGITS IN DRAWING NAME INDICATE REVISION NUMBER
PG: 4	OF: 4

BILL OF MATERIALS

ITEM	QTY	PART NUMBER	DESCRIPTION
1	1	50-1712	FILTER,REGULATOR,1/4" NPT MINI
2	1	53-0322	GAUGE,0-160 1/8 NPT
3	1	50-1713	LUBRICATOR,SMC,1/4" NPT MINI
4	3	53-0291	FLOW CONTROL VALVE,FC82A-AA
5	3	50-1904	VALVE,SOLENOID,MAC,2 PS STACK 4 WAY
6	2	50-1164	CYLINDER,HUMPHREY,1,0625" BORE 2.5
7	2	50-1166	CYLINDER,HUMPHREY,1,0625" BORE,1.5"

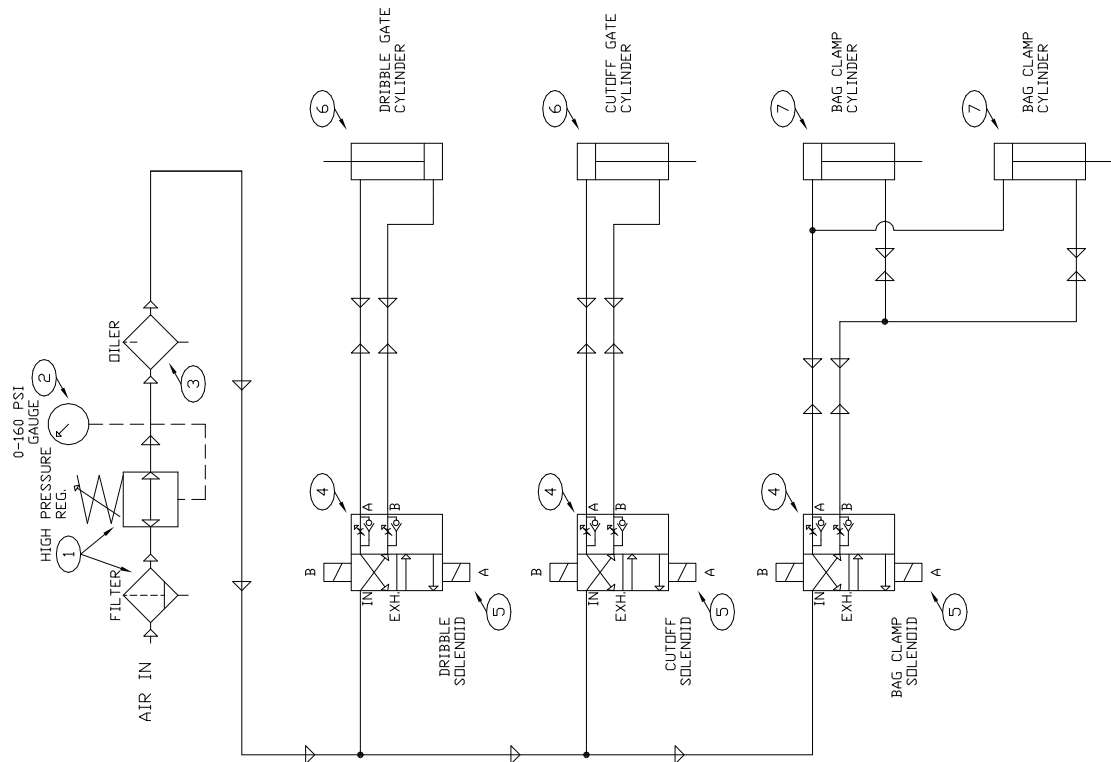

MODEL: TE-100 T4000	CUSTOMER NAME: TE-100 T4000
VIEW.: PNEUMATIC	CUSTOMER TAG #:
SCALE: 3/8" TP #:	DRAWING DATE: 12/18/07
DRAWN BY: CS	REVISED BY: EON #:
P.O. #:	DRAWING NAME: TE-100-1-500-00
ORDER #:	LAST 2 DIGITS IN DRAWING NAME INDICATE REVISION NUMBER
PG.: 1	OF: 1

WIRING DIAGRAM

BILL OF MATERIALS		
QTY	PART NUMBER	DESCRIPTION
1	50-1017	LIMIT SWITCH
2	50-1904	SOLENOID

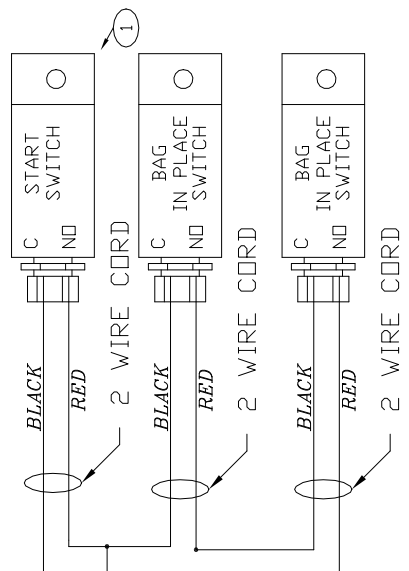
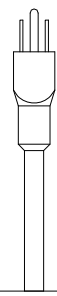
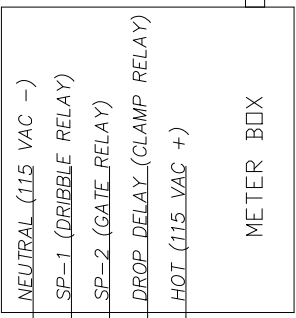

WIRE TO START SWITCH & BAG IN PLACE ON THIS SIDE

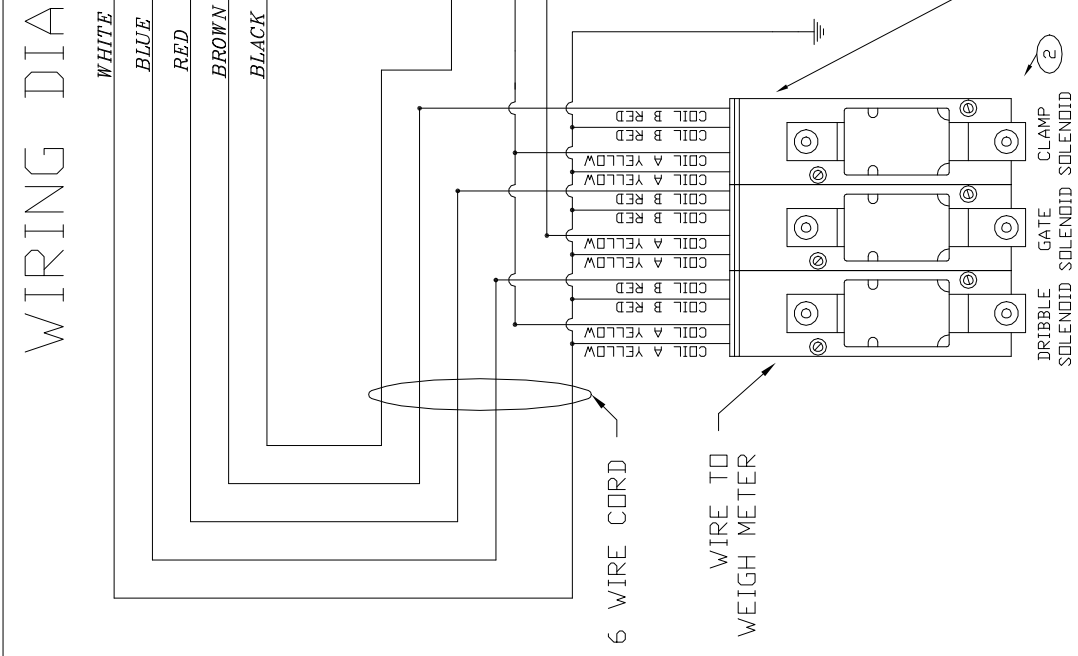

WIRING SCHEMATIC

115 VAC

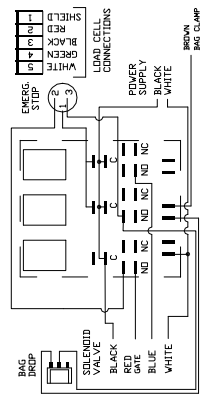
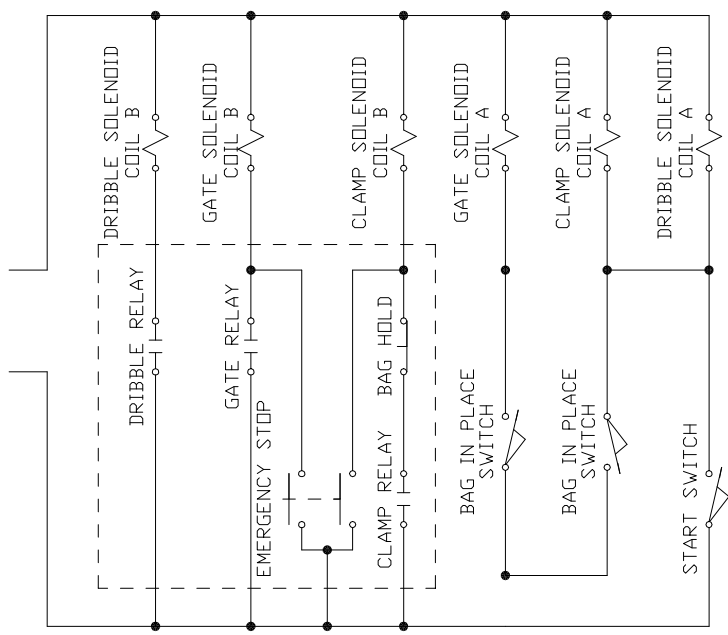

Taylor Products Co. Inc.
1492 22000 Rd, Parsons Kansas 67357

MODEL: _____

VIEW: SCHEMATIC

SCALE: 1/4" TP # _____

DRAWN BY: CS CHECKED BY: _____

P.O. # 45643

ORDER # _____ PG: 1 OF 2

CUSTOMER NAME: TAYLOR

CUSTOMER TAG # _____

DRAWING NAME: TE1002BIP

ORIGINATION DATE: 12/18/06

REPLACED DRAWING: _____

REPLACED DATE: _____

REPLACED BY DRAWING: _____

CUSTOMER NAME: TAYLOR

CUSTOMER TAG # _____

DRAWING NAME: TE1002BIP

ORIGINATION DATE: 12/18/06

REPLACED DRAWING: _____

REPLACED DATE: _____

REPLACED BY DRAWING: _____

Appendix E

Seed Count Option

General Description

When the order is placed for a TE100, the Seed Count option may be selected. This option is a special firmware upgrade for the existing T4000 system. This option allows the operator to select Seed Count mode from the T4000 menu system. The operator may then input the following values:

- Number of Seed in Sample
- Weight of Sample
- Total Seed Count

Once the values have been entered into the system, the operator will press the TGT function key and the system will calculate and display the Target Weight automatically.

Setup Procedures

There are several steps that must be taken to setup this option. Those steps can be broken down into three basic functions:

- Changing the instrument type
- Entering the parameters
- Setting the target weight

Changing The Instrument Type

Use the following steps to change the instrument type:

1. Turn the TE100 on and allow it to warm up.
2. Press the function button under the word **MENUS** on the standby menu.

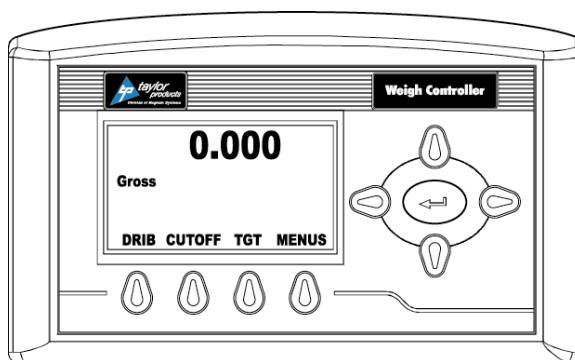

Figure E-1. Standby Menu

3. The Configuration menu will be displayed.

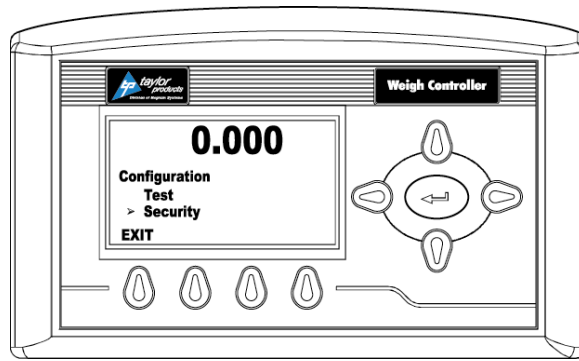

Figure E-2. Configuration Menu

4. Use the up/down arrows to place the cursor in front of the Security line and press the enter key.
5. The Security menu will be displayed.
6. Use the up/down arrows to place the cursor in front of the Enter Key Code line and press the enter key.
7. Use the up/down arrows to enter the key code. Once all digits are entered, press the enter key.
8. Use the up/down arrow keys to place the cursor in front of the Inst. Type line.
9. Use the left/right arrow keys to toggle until SC-TE100 is displayed, and then press the enter key.

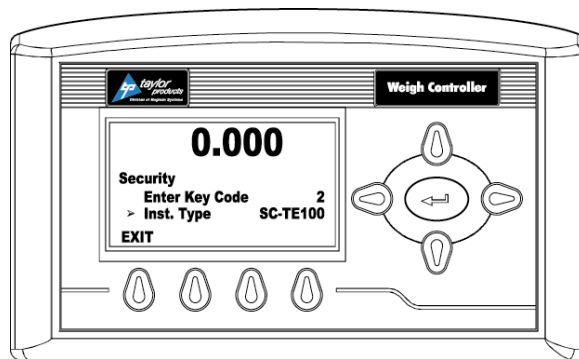

Figure E-3. Security Menu

10. Press the function key under the word EXIT two times to return to the standby menu.

Entering Parameters

Use the following steps to enter the seed count parameters.

1. From the standby menu, press the function button below TGT on the display.

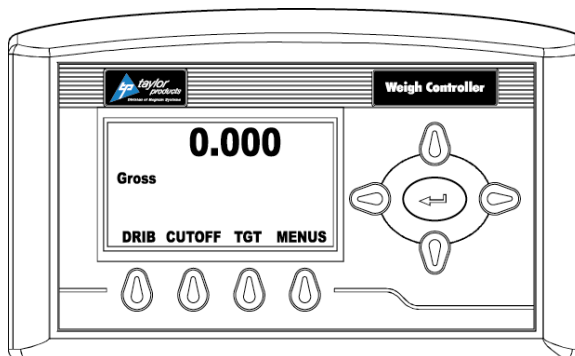

Figure E-4. Standby Menu

2. The Seed Count Setpoint menu will appear.

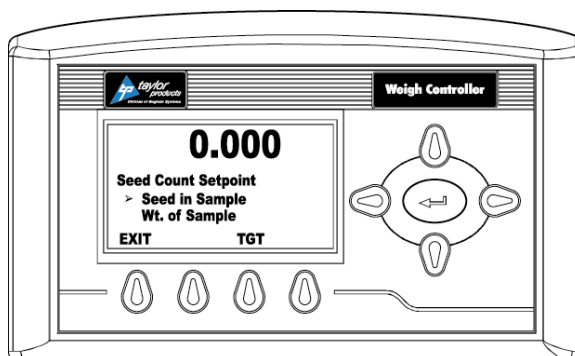

Figure E-5. Seed Count Setpoint Menu

3. Use the up/down arrow keys to place the cursor in front of the Seed in Sample line.
4. Press the enter key to select Seed in Sample.
5. The Seed in Sample menu will appear.

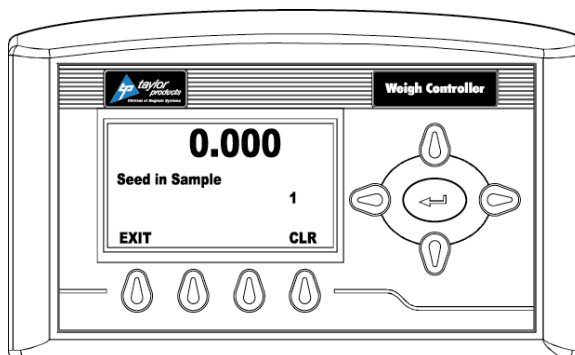

Figure E-6. Seed In Sample

6. Using the up/down arrow keys to increase/decrease numbers, and the left/right arrow keys to change cursor position, enter the number of seeds in the sample.
7. Press the enter key to save. The Entry Accepted message should appear.
8. Press the function key below the word EXIT on the display to go back to the Seed Count Setpoint menu.

9. Use the up/down keys to place the cursor in front of the Wt. of Sample line.
10. Press the enter key.
11. The Wt. of Sample menu will appear.

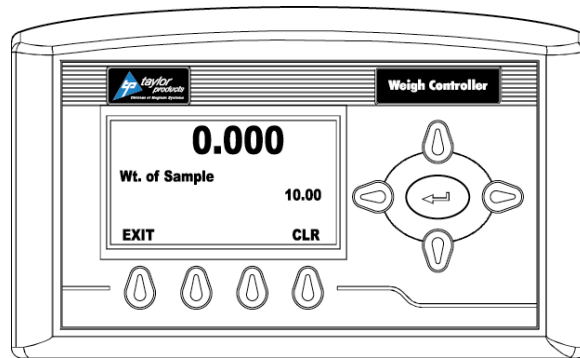

Figure E-7. Wt. of Sample Menu

12. Using the up/down arrow keys to increase/decrease numbers, and the left/right arrow keys to change cursor position, enter the weight of the sample.
13. Press the enter key to save the setting. The Entry Accepted message should appear.
14. Press the function key below the word EXIT on the display. The Seed Count Setpoint menu will appear.
15. Use the up/down arrow keys to place the cursor in front of the Total Seed Ct line.
16. Press the enter key.
17. The Total Seed Ct menu will appear.

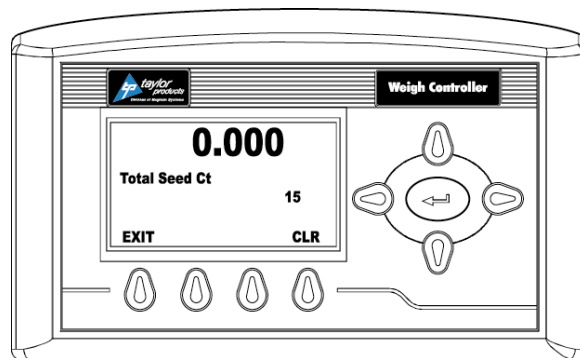

Figure E-8. Total Seed Ct. Menu

18. Using the up/down arrow keys to increase/decrease numbers, and the left/right arrow keys to change cursor position, enter the number of seeds.
19. Press the enter key to save the setting. The Entry Accepted message should appear.
20. Press the function key below the word EXIT on the display two times to return to the standby menu.

Setting The Target Weight

Use the following steps to enter the desired target weight.

1. From the standby menu, press the function key below the word MENUS on the display. The Seed Count Setpoint menu will appear.

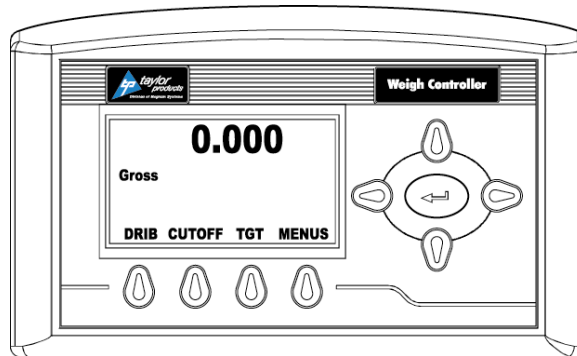

Figure E-9. Standby Menu

2. Press the function key below TGT on the display. The Target Weight menu will appear.
3. Using the up/down arrow keys to increase/decrease numbers, and the left/right arrow keys to change cursor position, enter the desired target weight.

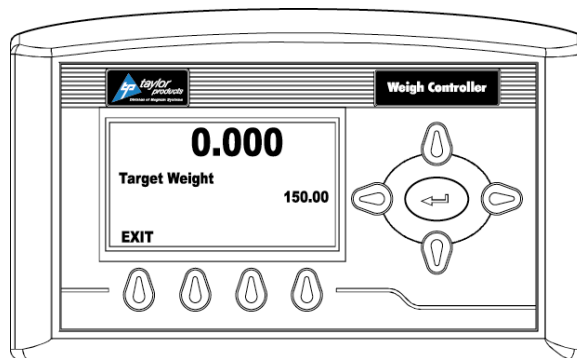

Figure E-10. Target Weight Menu

4. Press the enter key. The Entry Accepted message should appear.
5. Press the function key under the word EXIT on the display to return to the standby menu.

This Page Intentionally Left Blank