



ECONOMICAL BAGGING SCALE

MODEL OM-2

The OM2 Series scale utilizes Magnum Systems' patented beam scale and is self dampening. The weight pointer and calibration adjustment are located directly on the beam. The OM2 Series flow control regulates the speed of material going through the scale.

SIMPLE AND ACCURATE GRAVITY WEIGH SCALE

Features

- Mechanical Beam Scale Operation
- Nonconcentric bag clamp for positive grip
- Adjustable flow gate

Materials Typically Handled are dry, granular, free flowing products such as:

- Wheat
- Feed Mixes
- Granular Fertilizer
- Cracked Corn
- Deer Corn Mixes

Fun Facts

- More than 3,000 Installations World Wide
- Has been manufactured since 1972



Price: \$3,080.00

*We accept all major credit cards
Shipping not included*



Engineering, Design & Manufacturing
to Keep the Line Moving

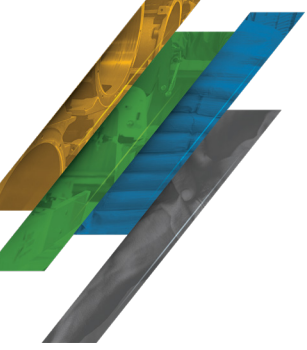

ECONOMICAL BAGGING SCALE

MODEL OM-2

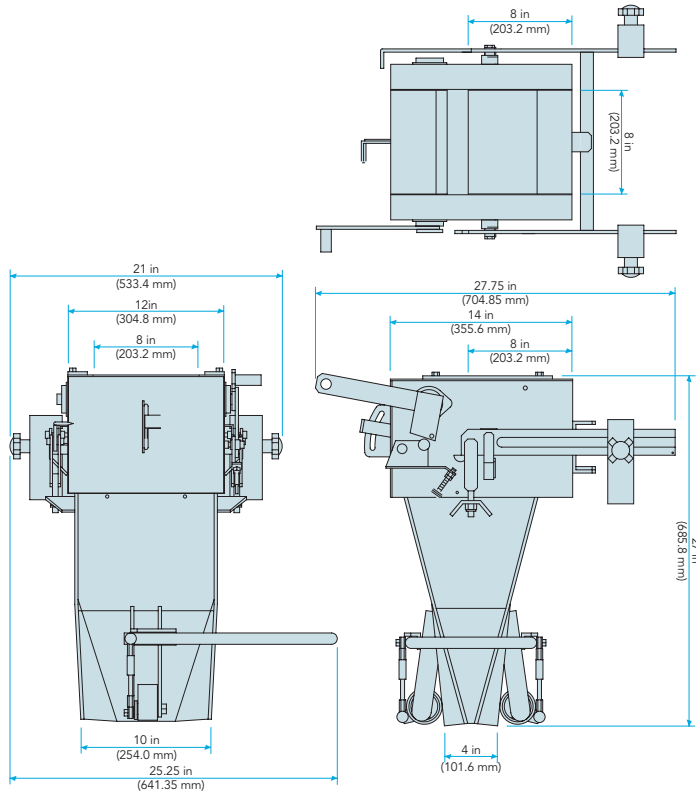

Diagram dimensions are for reference only*

SPECIFICATIONS

Speed	Up to 15 BPM
Accuracy	± 0.5 lbs
Weight Range	15 to 125 lb (6.8 kg to 56 kg) <i>Weight range is dependent on product's bulk density. Free product testing recommended.*</i>
Construction	Carbon Steel
Paint Color	Magnum Systems Blue - RAL 5015
Bagger Overall Dimensions	L 27.75" x W 25.25" x H 27"
Shipping Weight	160 lbs
Crate Dimensions	L 22"x W 37"x H 35"

Proud Members:



©2020 Magnum Systems, Inc. All rights reserved. Catalog number MS.1034.0420QS



www.magnumsystems.com

Toll Free 888.882.9567 Fax 620.421.5531

Corporate 2205 Jothi Avenue, Parsons, Kansas 67357