



MANUAL BAG UNLOADING

BAG DUMP STATION

Magnum Systems bag dump stations are utilized for manual entry of product into a system. Designed to handle up to 50lb (25kg) bags with integral hopper allows for consistent entry of product to a flex auger, conveyor, or pneumatic transfer system. Stainless steel construction is standard with leg supports for rigid installation in multiple applications. Hinged door, grate, 4" dust vent and integral hopper are basic features of the small bag unload station. Optional bag shelf and work platform increase operator safety and ease of use. Integrating a self-contained bin vent and exhaust fan provides for a dust free environment during unloading. The standard discharge flange is designed for use with a Smoot airlock valve and can be modified for additional metering or discharge device.

Basic Features:

- Stainless steel construction
- Grate for operator safety
- Hinged door for contained operation
- Dust collection vent

Optional Features:

- Bag Shelf
- Workstation Platform
- Food grade finish
- NEMA 7/9 classified electrical components

Dust Collection Option:

- Integrated Bin Vent
- Exhaust Fan
- Limit Switch on Door
- NEMA 4 classified electrical components



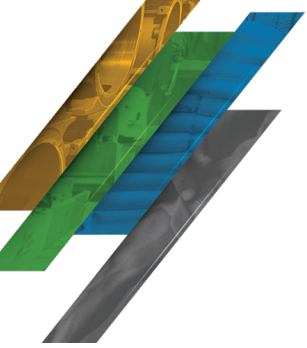

MANUAL BAG UNLOADING

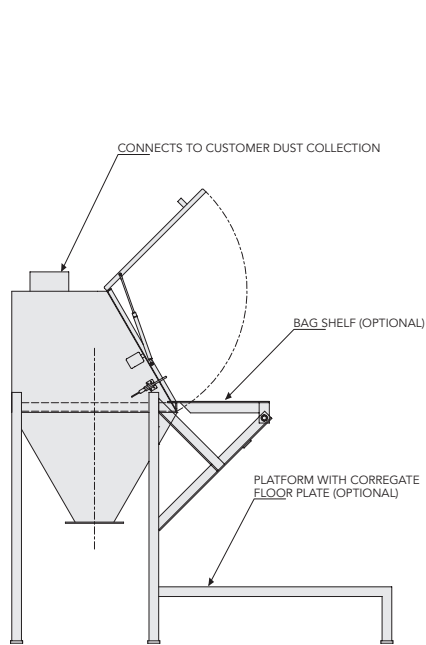

SIDE VIEW SHOWING VENT LINE STUB

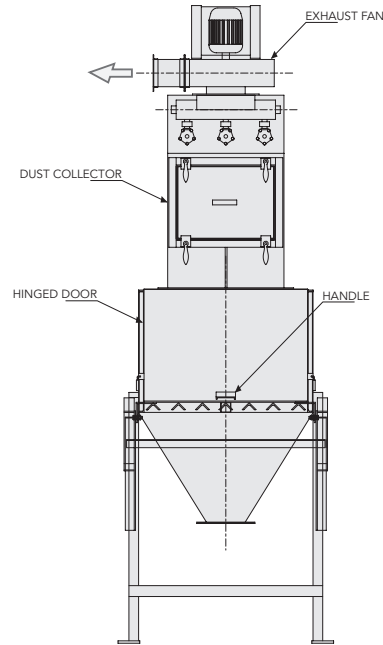

FRONT VIEW SHOWING OPTIONAL PULSE JET FILTER

Diagram dimensions are for reference only*

SPECIFICATIONS

Dust Vent	4" OD
Construction	Stainless Steel
Electrical	NEMA 4

BAG DUMP LOCATION IN A SYSTEM

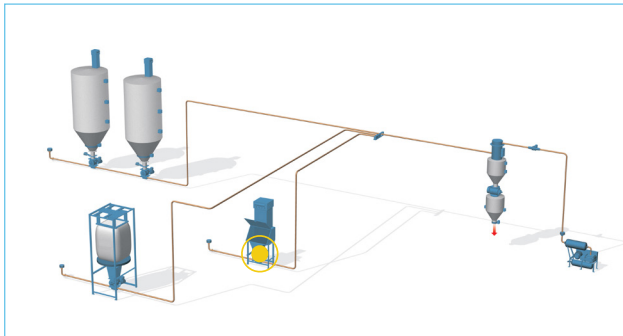

INTEGRAL DUST COLLECTION



GRATE VIEW



©2018 Magnum Systems, Inc. All rights reserved. Catalog number MS.4019.0718