



SMOOT

TAYLOR

# ULTRASONIC VALVE BAG SEALER

## TRU SEAL

Magnum Systems' Model TRU Seal ultrasonic valve bag sealer. The TRU Seal has been specifically designed to work with Magnum valve bagging equipment and incorporates the latest ultrasonic sealing technology.

### SEAL VALVE BAGS WITH INNOVATIVE ULTRASONIC TECHNOLOGY

- Ultrasonic waves alter molecular structure of sealing agent without heat, which reduces product degradation
- Rigid mount setup at filling source decreases amount of bag movement while maintaining bag shape
- Ultrasonic waves displaces product from seal area providing a clean, positive seal
- Helps prevent product loss during shipping
- Capable of both plastic and paper valve sealable bags
- Works well with dusty, fluid, powder, and hydroscopic products
- Can be used with any of Magnum Systems valve bag fillers



One Partner For All Your Material Handling Needs.

# ULTRASONIC VALVE BAG SEALER

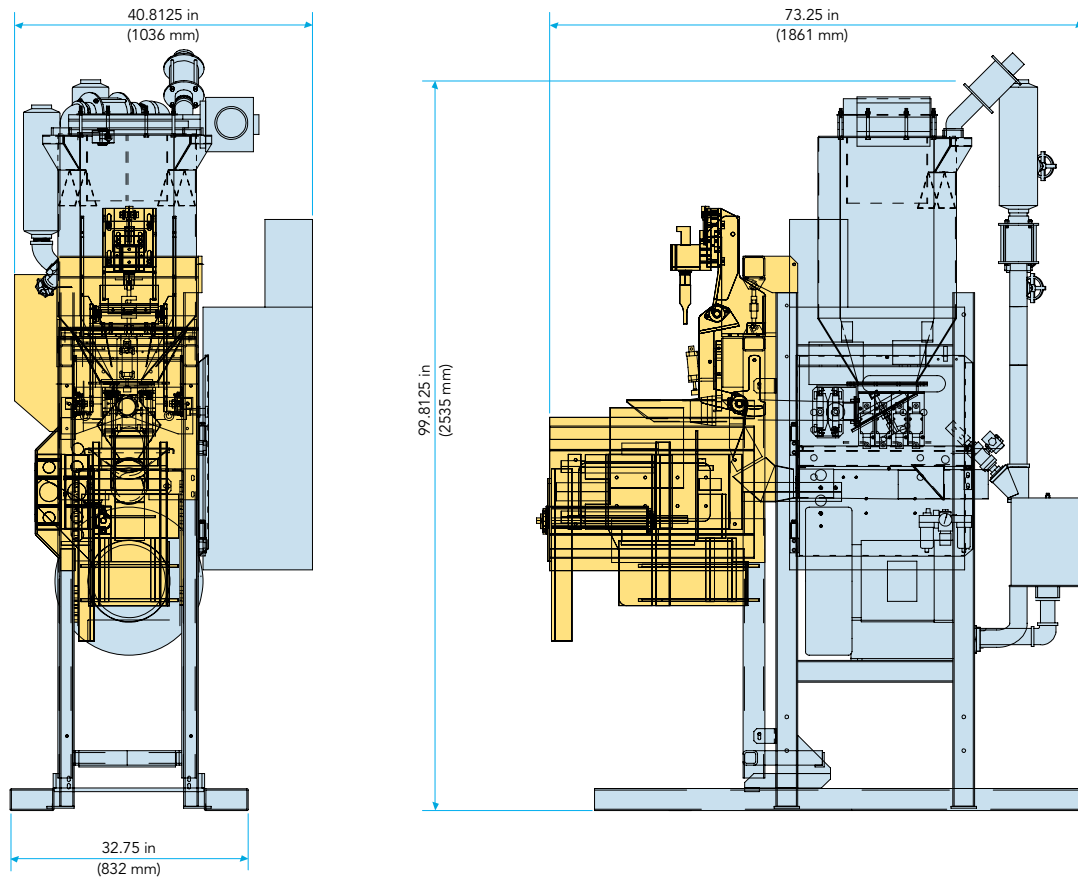

Diagram dimensions are for reference only\*

## SPECIFICATIONS

Speed	Dependent on bagging machine and product
Configuration	Rigid mount
Construction	Carbon steel
Electrical Requirements	480 volt, 3 ph, 40 amps
Air Requirements	5 SCFM @ 80/100 PSIG



©2024 Magnum Systems, Inc. All rights reserved. Catalog number MS.1029.0824



[www.magnumsystems.com](http://www.magnumsystems.com)

Toll Free 800.748.7000 Fax 913.362.7863  
7945 Flint Street, Lenexa, KS 66214