



# AUTOMATIC BAG PLACER

## MODEL TOMP

Magnum Systems' Model TOMP Automatic Open Mouth Bag Placer will place kraft bags on the spout of an electronic bagging scale at a rate of up to eight bags per minute. The vertical carousel bag magazine can be easily loaded while the machine is in operation. The small footprint makes installation in limited floor space possible.

### **AUTOMATED BAGGING FOR CONSISTENT PACKAGING OPERATIONS**

#### **Features**

- Automatic bag magazine, vertical carousel, and bag trays
- Adjustable height for bag lengths up to 42"
- Suction bag gripper and dual placing arms
- Bag settler
- TSC sealing conveyor with adjustable pedestal
- Integral controls

#### **Optional Features**

- Bag reformer
- Stainless steel construction
- Downstream sealing, conveying, and palletizing equipment

#### **Bags Handled**

- Kraft bags

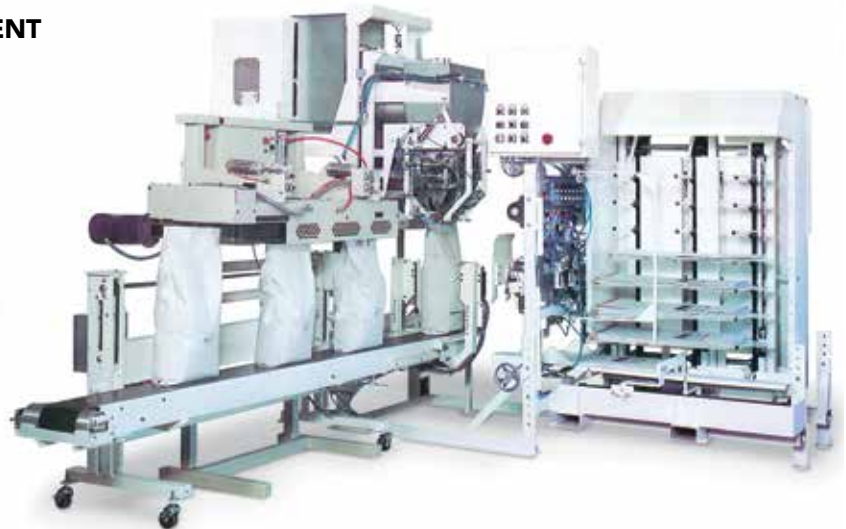

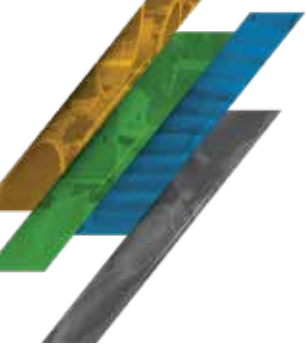

# AUTOMATIC BAG PLACER

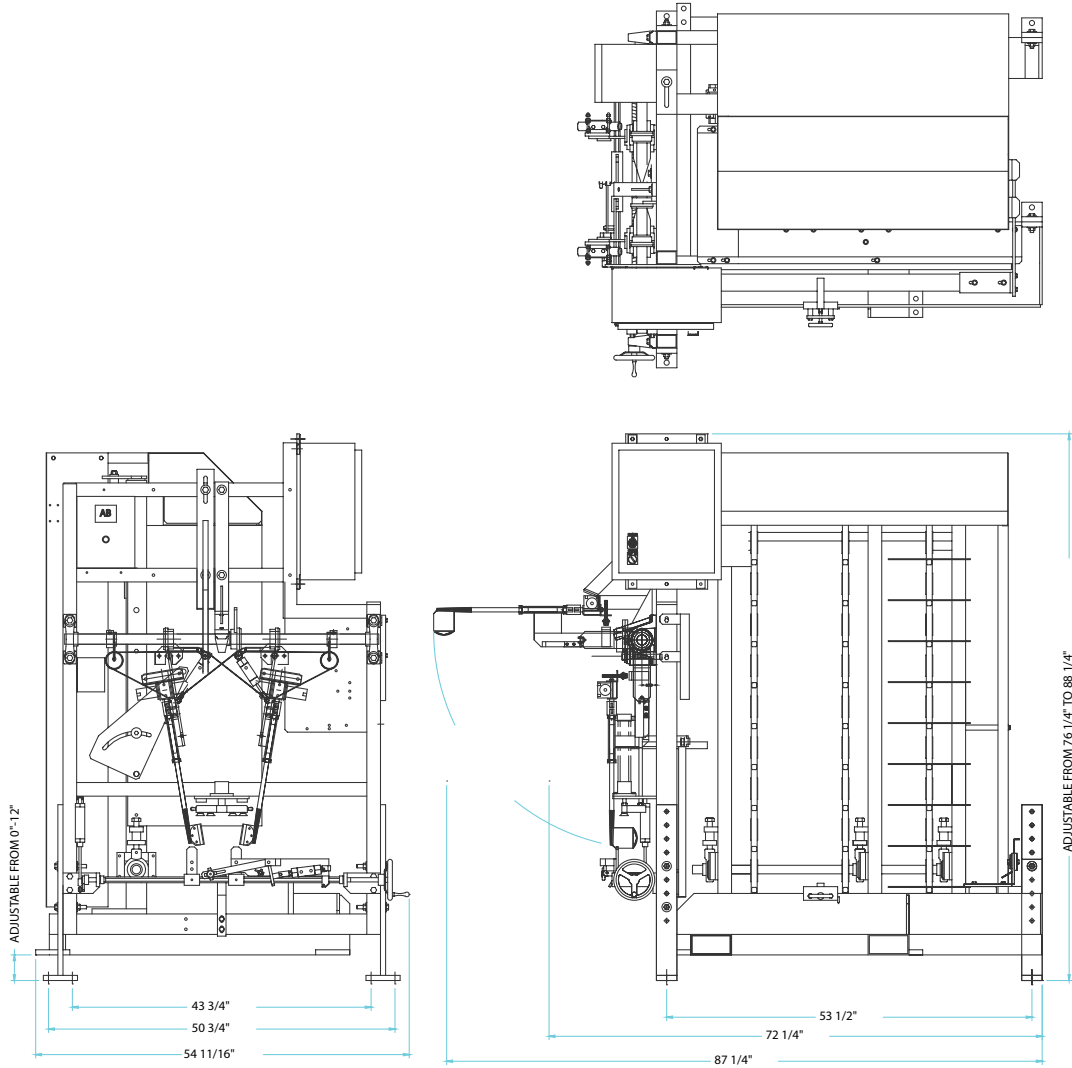

Diagram dimensions are for reference only\*

## SPECIFICATIONS

Speed	8 BPM
Bag size	Kraft bags up to 42" tall
Construction	Carbon steel, blasted, and painted
Electrical requirements	120 V, single phase
Air requirements	90 psi, 5 cfm
Enclosures	NEMA12 (Explosion class and division ratings available)



©2024 Magnum Systems, Inc. All rights reserved. Catalog number MS.1065.0824



[www.magnumsystems.com](http://www.magnumsystems.com)

Toll Free 800.748.7000 Fax 913.362.7863  
7945 Flint Street, Lenexa, KS 66214