



BULK-BAG/DRUM/BOX FILLING

MODEL IBC-3000

Magnum Systems' IBC-3000 Fillers are engineered for a variety of materials and containers. The IBC's modular design allows complete flexibility from a free-standing manual operation to a fully integrated and automated system handling bags, drums, and boxes.

COMPLETE BULK STORAGE AUTOMATION WITH SIMPLICITY AND FLEXIBILITY

Features

- Up to 3,000 lb capacity
- Adjustable bag clamps for various bag sizes
- Inflatable neck seal and spout
- Double-wall fill spout for dust collection

Optional Features

- Stainless-steel construction
- Bag liner inflater
- Automatic bag strap and neck seal release
- Drum or box hood
- Lift platform
- Platform vibration
- Pallet dispenser
- Conveyor system out-feed
- Integrated controls

Materials Typically Handled

- Powders
- Granulars



IBC-3000 shown with optional lift platform, pallet dispenser, and conveyor system.

BULK BAG/DRUM/BOX FILLING

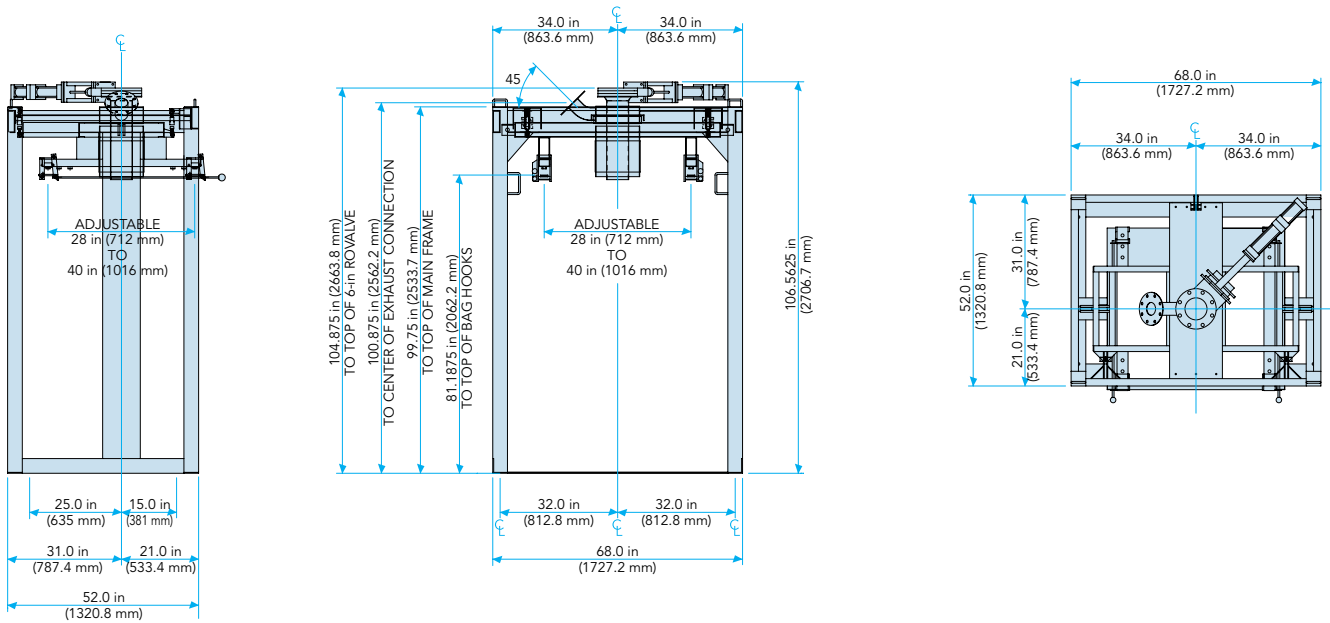
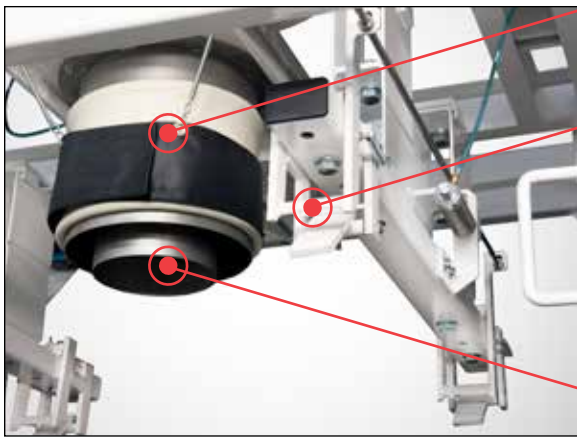

Diagram dimensions are for reference only*

SPECIFICATIONS

Speed	Up to 15 BPH or up to 50 DPH
Accuracy	Up to 0.1%
Weight Range	100 to 3,000 lb (45 to 1,361 kg), up to 6,000 lb (2,722 kg) with special options
Construction	Tubular carbon steel blasted and painted
Electrical Requirements	115 volt, single phase
Air Requirements	90 PSI (6 BAR)

BAG FILLING FEATURES



- Inflatable neck seal and spout
- Automatic bag strap and neck release
- Dual wall discharge for dust collection



©2024 Magnum Systems, Inc. All rights reserved. Catalog number MS.1010.0824