



SMOOT

TAYLOR

BULK-BAG UNLOADING

MODEL IBC-2000

Magnum Systems' IBC-2000 is adaptable to nearly any discharge or de-weigh application. It is constructed of heavy-duty tubular steel with a compact footprint of 60 by 60 inches. The IBC-2000 integrates with loss-in-weight feeders, rotary valves, and pneumatic transfer systems. Easily modified with multiple options in order to handle your dry bulk solids materials.

COMPLETE BULK UNLOADING WITH SIMPLICITY AND FLEXIBILITY

Features

- Up to 4,000 lb capacity
- Adjustable frame for various bag sizes
- Fork lift design with universal pickup device (UPD)
- Bag pan protects operators during product discharge
- Untie box for easy bag-spout access and dust-collection port

Optional Features

- Bottom-bag and/or side-bag agitators
- Hoist/trolley design with UPD
- Automatic bag cutoff
- Untie box for easy bag-spout access
- Load cell/scale package for de-weighing and inventory control
- Integral controls package

Materials Typically Handled

- Powders
- Fertilizer
- Calcium
- Salt
- Resins

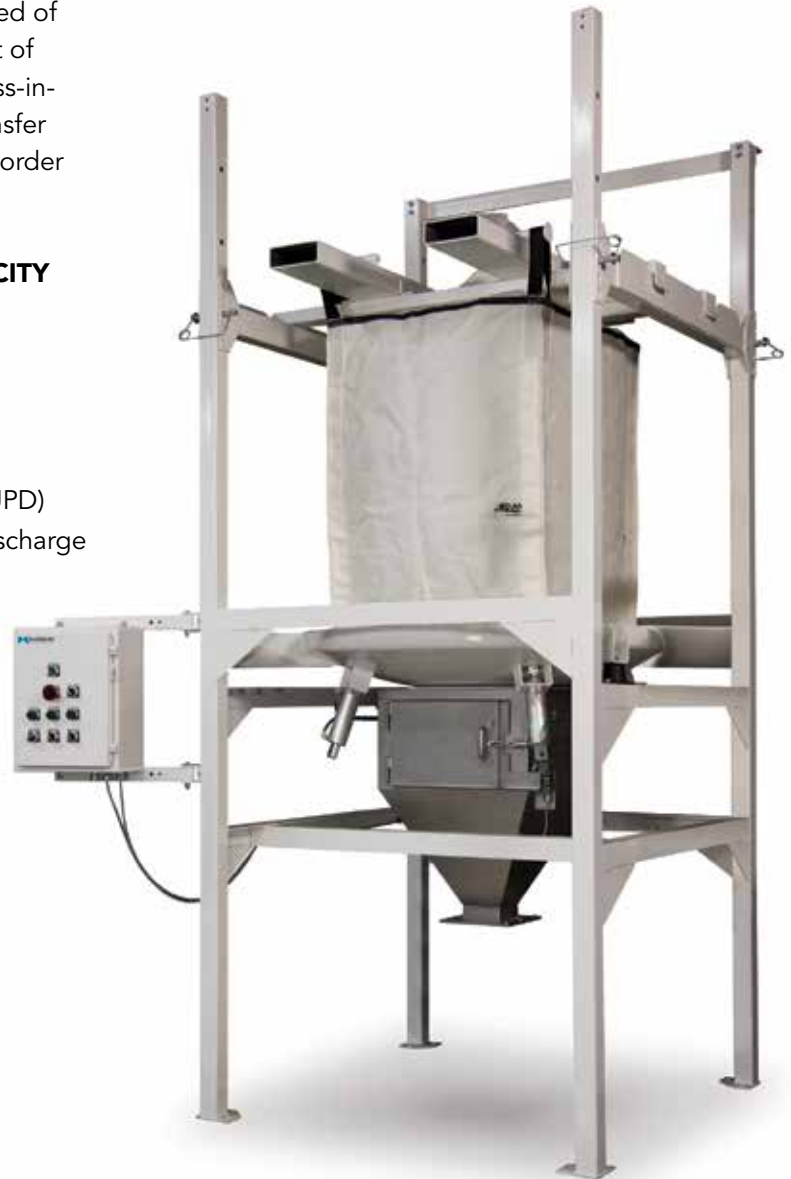

One Partner For All Your Material Handling Needs.

BULK-BAG UNLOADING

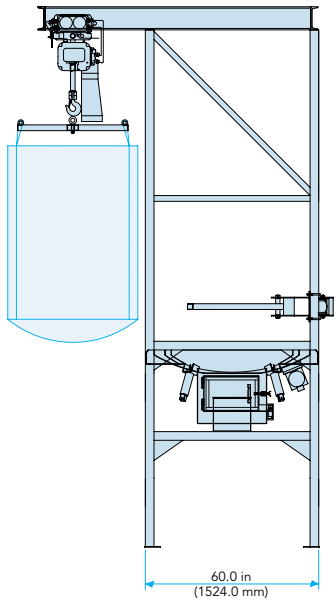

SIDE VIEW

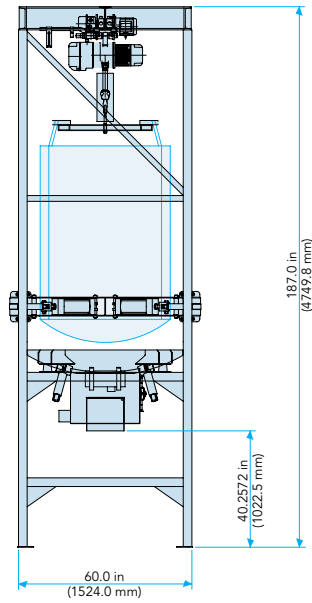

FRONT VIEW

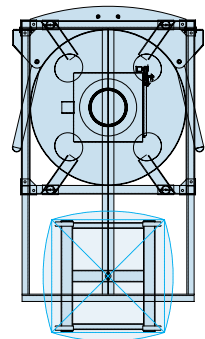

TOP VIEW

Diagram dimensions are for reference only*

SPECIFICATIONS

Speed	Up to eight bags per hour
Accuracy	Up to 0.1%
Weight Range	100 to 4,000 lb (45 kg to 1,814 kg)
Construction	Tubular carbon steel blasted and painted
Electrical Requirements	Dependant on model and options
Air Requirements	Dependant on model and options

HOIST, TROLLEY, AND UPD



UNTIE BOX DISCHARGE



SIDE AND BAG-PAN AGITATORS



©2024 Magnum Systems, Inc. All rights reserved. Catalog number MS.1026.0824



www.magnumsystems.com

Toll Free 800.748.7000 Fax 913.362.7863
7945 Flint Street, Lenexa, KS 66214