



SMOOT

TAYLOR

VALVE BAG AUGER PACKER

MODEL GWAP

Magnum Systems' GWAP Auger Packer is excellent for bagging a wide range of products, including seeds, resins, plastics, sand, rubber granulars, fertilizers, and abrasives. Practical design makes the GWAP transportable and adaptable to existing construction. To operate, place the bag on the spout and pull gate handle to start—fill shuts off automatically.

ECONOMICAL VALVE-BAGGING EQUIPMENT

Features

- Designed to fit a standard 5 1/2" valve bag
- Screw feeder
- Mechanical flow-control gate
- Mechanical beam scale

Optional Features

- Stainless steel construction/contact areas
- Downstream conveying and palletizing equipment

Materials Typically Handled

- Wheat, rice, and grains
- Granular fertilizer
- Pelleted feed
- Plastics
- Resins

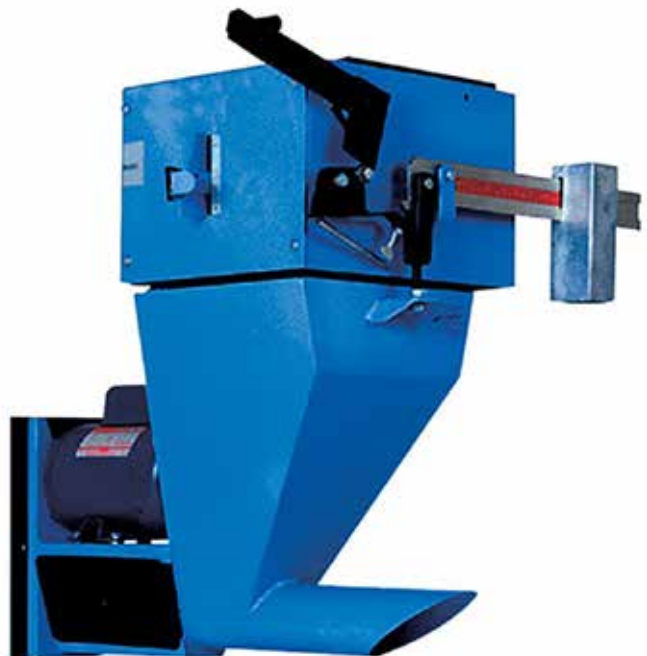

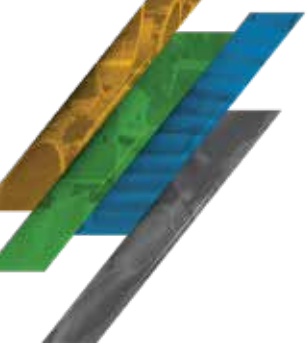

VALVE BAG AUGER PACKER

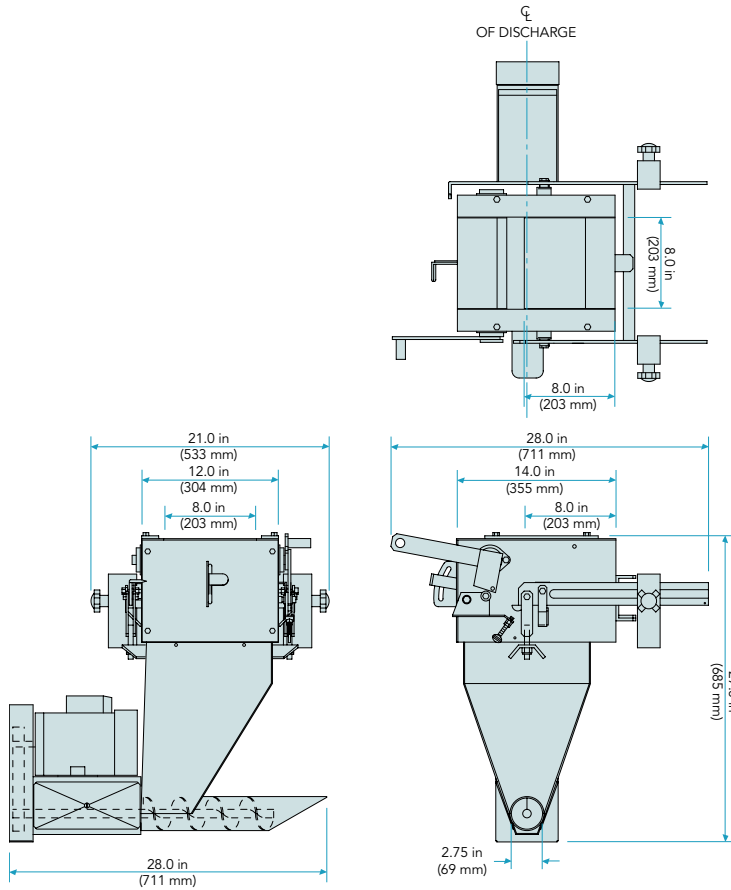

Diagram dimensions are for reference only*

SPECIFICATIONS

Speed	Up to 3 BPM
Accuracy	± 0.4 lb
Weight Range	15 – 125 lb
Scale	Beam
Construction	Carbon steel blasted and painted
Electrical Requirements	115 V, single phase



©2024 Magnum Systems, Inc. All rights reserved. Catalog number MS.1037.0824



www.magnumsystems.com

Toll Free 800.748.7000 Fax 913.362.7863
7945 Flint Street, Lenexa, KS 66214