



# OPEN MOUTH BAG AUGER PACKER

## MODEL APO

Magnum Systems' Model APO is designed to handle powder products that aerate, bind, cake, or bridge easily. The variable speed auger option uses a bulk and dribble feeding technology and ensures a fast and accurate weight measurement.

### USE SPEED AND PRECISION TO PACKAGE DIFFICULT TO FEED OR FLUIDIZED MATERIALS

#### Features

- Product agitator for material conditioning
- Variable speed auger for bulk and dribble feeding
- Enclosed discharge area and inflatable bag spout for dust control
- T-4000 weigh controller with digital readout

#### Optional Features

- Stainless steel contacts for food grade
- De-aeration probes to stabilize fluidized products
- Bag settler
- Container platform and lift
- Removable screw and agitator
- Dropout bottom for ease of cleaning
- T-3000 weigh controller
- Integral controls package

#### Additional Equipment Can Be Used With:

- Automatic bag placer
- Sealing conveyors
- Bag closer (sealer or sewer)
- Bag knockdown/turners
- Bag flattening
- TRP-3000 - robotic palletizing



#### Materials Typically Handled

- Flours and starches
- Spice and bakery blends
- Animal nutrient blends
- Industrial chemicals
- Oily products with low-bulk density
- And more

One Partner For All Your Material Handling Needs.

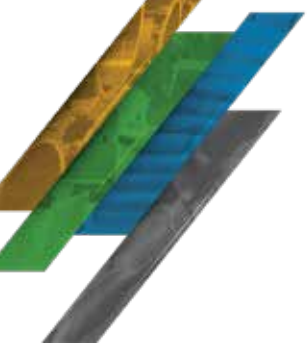

# SINGLE AUGER PACKER

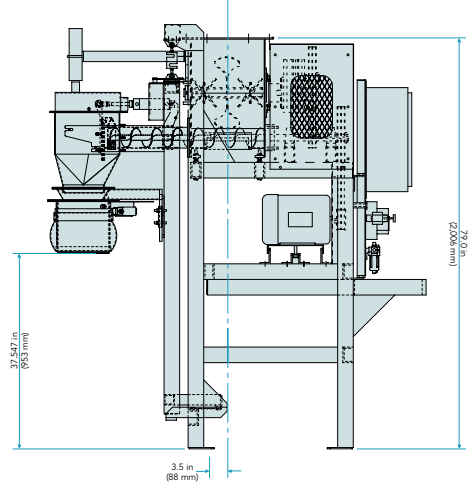
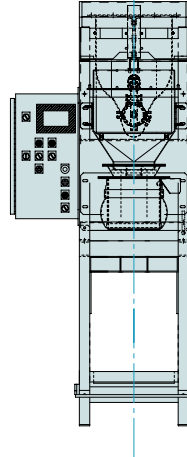
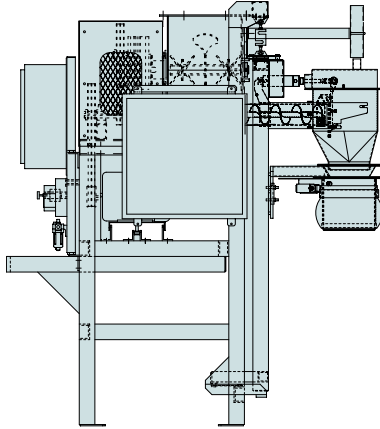
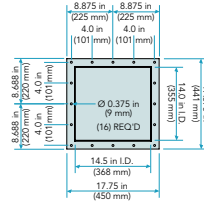

Diagram dimensions are for reference only\*

## SPECIFICATIONS

Speed	Up to three bags per minute
Accuracy	± 0.2 lb
Weight Range	15 to 125 lb (9 to 56 kg) <i>(Weight range is dependent on product's bulk density. Free product testing recommended.)*</i>
Scale	Load cell with digital display
Construction	Frame, carbon steel blasted & painted
Electrical Requirements	230/460 volt, 3 phase, 60 hertz for motors   120 VAC, 1 phase, 60 hertz for controls
Air Requirements	90 PSI (6 BAR) compressed air at 5 SCFM <i>(Compressed air must be clean and dry)*</i>
Inflatable Bag Clamp Capacity	60 lb (27 kg); capacities greater than 60 lbs require the optional bag support platform
Auger	4" OD, carbon steel, stainless steel is optional
Enclosures	NEMA12



### AUGER SPOUT FLAP GATE

- Quick release pins for ease of maintenance and clean out
- Increase filling accuracy



### INFLATABLE BAG SPOUT

- Dust control
- Positive seal on bag



©2024 Magnum Systems, Inc. All rights reserved. Catalog number MS.1035.0824



[www.magnumsystems.com](http://www.magnumsystems.com)

Toll Free 800.748.7000 Fax 913.362.7863  
7945 Flint Street, Lenexa, KS 66214