



MAGNUM
S Y S T E M S

2205 Jothi Avenue, Parsons, Kansas 67357
Toll Free 888.882.9567 • Fax 620.421.5531
magnumsystems.com

NOTICE

**THIS ENVELOPE CONTAINS
IMPORTANT DOCUMENTS**

DO NOT DESTROY

ROTARY VALVE
O&M DOCUMENTATION

MODEL: TYPE 1, 2, 3, 4, 5, & 8
SIZE: FT22

N10-340

NOTICE

**THIS ENVELOPE CONTAINS
IMPORTANT DOCUMENTS**

DO NOT DESTROY



MAGNUM SYSTEMS ROTARY VALVE AIRLOCK FEEDER INSTALLATION & MAINTENANCE INSTRUCTIONS

WARNING! READ ALL INSTRUCTIONS. FAILURE TO FOLLOW SAFETY RULES LISTED BELOW, AND OTHER BASIC SAFETY PRECAUTIONS, MAY RESULT IN SERIOUS PERSONAL INJURY!

WARNING! When installing Airlock Feeder DO NOT connect to the power source until chain guard is in place and the Airlock inlet and outlet are covered so that there is no chance for fingers and hands to get close to rotating blades.

WARNING! Disconnect Airlock Feeder motor from power source before attempting to make any repairs.

DANGER! Keep chain guard in place and keep both the inlet and outlet covered when the feeder is connected to a power source.

DO NOT TRY TO FORCE THE ROTOR TO TURN WITH YOUR HANDS!

After disconnecting power to Airlock, use a board between the blades or use a pipe wrench on the non-drive end of the rotor shaft in order to turn the Airlock rotor by hand. If the rotor does not turn relatively easy, look for the cause of the problem. Remember the Airlock is a precision piece of equipment and can be easily damaged if not handled properly by personnel trained to work on precision equipment. There are numerous reasons why the Airlock rotor could be binding. If you are unable to find the problem yourself, consult Magnum Systems trained factory personnel. It may be something that can be diagnosed over the phone. If not, you may have to send the Airlock to the Magnum Systems factory or obtain the services of a trained Magnum Systems technician.

CAUTION! All repairs, electrical or mechanical, should be attempted only by trained repairmen.

STAY ALERT! Watch what you are doing. Use common sense. Do not attempt to operate airlock feeder without the chain guard in place and without inlet and outlet covers in place.

THE PEOPLE, PARTS, AND SYSTEMS THAT KEEP THE LINE MOVING.



MAGNUM SYSTEMS AIRLOCK LONG TERM STORAGE INSTRUCTIONS.

Rotary Valve Airlocks should be stored Indoors, in a dry ambient facility.

They should be stored on a pallet with the inlet and outlets covered.

Do not place valves where any other moisture can enter into the valve.

For long-term storage over 30 days, it is recommended that the internal carbon steel surfaces be sprayed with a rust preventative coating, such as, vegetable oil to prevent internal rust from forming.

Magnum Systems also recommends

The rotor should be turned every 30 days while in storage. Please refer to the IO&M instructions for the proper and safe method for turning the rotor.

THE PEOPLE, PARTS, AND SYSTEMS THAT KEEP THE LINE MOVING.



FT22 (All types Except Type 6) AIRLOCK FEEDER INSTALLATION & MAINTENANCE INSTRUCTIONS (Ref. Dwg. #IO5B-2-CA)

I. LUBRICATION INSTRUCTIONS

1. The drive end shaft bearing (Part No. 16) is equipped with two (2) grease retention seals and is factory lubricated. These bearings **DO NOT** require lubrication for the lifetime of the bearing.
2. The thrust end bearings (Part No. 10) are packed in grease at the factory and need not be re-greased unless the bearings are removed. To re-grease these bearings proceed in the following manner:

Remove the bearings (See Instruction IV for end plate and bearing removal; See Instruction VI for reassembly) and place the bearings in a suitable container with a clean petroleum solvent or kerosene and allow the bearings to soak, preferably overnight. Then turn the bearings slowly and work with a brush to dislodge chips or solid particles. After cleaning, bearings should be spun in light oil to remove the solvent completely. Pack bearings with a good grade of bearing grease.

3. MOST GEAR MOTORS [but not all] are shipped to Magnum Systems with a sufficient quantity of lubricant for operation. BEFORE OPERATION, the user is responsible for checking to see that the gear motor has oil to the proper level. Most gear motors are supplied with three pipe plugs at different levels. The top [breather] plug is where oil is put in the gear head with breather plug removed. The center plug when removed is used to indicate when the proper amount of oil is in the gear head. When oil starts flowing out the center plug [with plug removed], sufficient oil is in the gear head and both the top [breather] plug and the center plug can be replaced. The purpose of the bottom [magnetic] plug is to be able to remove the oil from the gear head and of course should be in place except to drain oil out of the gear head. The customer should check and make sure the breather plug is the highest of the three plugs and the magnetic plug lowest of the three plugs. NOTE: Please refer to the operation instructions supplied by the gear motor manufacturer enclosed with your Airlock Feeder or the lubrication instruction plate on the gear motor for more details.

II. ROTOR SHAFT PACKING RINGS (Part No. 13)

1. There are two types of shaft seals used in our Airlock feeders. The most effective type (our standard) is polyurethane U-cup packing rings. All other types of packing rings are braided packing rings of one type or

THE PEOPLE, PARTS AND SYSTEMS THAT KEEP THE LINE MOVING.



another. High temperature packing rings are made of a braided PTFE fiber.

2. U-cup packing rings are endless. Braided packing is not endless and must be cut to the proper length. Braided packing when ordered from Magnum Systems will be pre-cut to the proper length for the Airlock size for which the braided packing is ordered. U-cups are self-energizing and need very little compression in order to be an effective shaft seal. In fact, too much compression will damage them. Braided packing rings on the other hand depend upon the proper amount of compression to be an effective shaft seal.
3. Installation of New U-Cup Packing Rings:
 - a. Remove end plates as per Instructions III and IV.
 - b. Before installing, dip new U-cup packing rings in a light oil. Press three (3) rings into each end plate with lips toward the inside. Install the gland plate and tighten the gland plate screws with an Allen wrench by hand until very light resistance can be felt, then lock the screws in place with the jam nuts against the bearing housing.
 - c. After both housing end plates have been installed per Instruction No. IV, check the U-cup packing rings to make sure they have only a slight amount of compression. Back off the two gland plate screws enough to be sure the U-cups are not being compressed and retighten the gland plate screws until very light resistance can be felt and lock them in place with jam nuts. **Do not over compress the U-cup packing rings.** The gland plate screws should be tightened only enough to snug the U-cup packing rings down against the packing seat. With the roller chain removed and the Airlock Feeder **NOT** connected to a power source, the rotor should rotate with some resistance caused by the lightly compressed U-cup packing rings when pulling on the rotor vanes using a approximately 3 foot long wood 2 by 4 between the vanes. As a safety precaution do not pull on the rotor vanes with your fingers.
4. Installation of Braided Type Packing Rings:
 - a. Remove end plates as per Instructions No. III & IV and remove the old packing rings from the end plates.
 - b. For each end plate, use three (3) braided rings.
 - c. The cut ends of the braided packing rings, when placed in the end plate, should be rotationally staggered. The gland plate can be used to push the packing rings down inside the packing gland in

THE PEOPLE, PARTS AND SYSTEMS THAT KEEP THE LINE MOVING.



each end plate. The gland plate can also be used to keep the packing rings in the packing gland when the end plate is installed onto the rotor shaft but do not compress the three braided packing rings with the gland plate at this time.

- d. After both housing end plates have been re-installed per Instructions No. V & VI, the gland plates can now be tightened down against the braided packing rings. The gland plate screws should be tightened so as to firmly compress the packing down against the shaft. With the roller chain removed, the rotor should rotate with some resistance when pulling on the rotor vanes using an approximately 4 foot long wood 2 by 4 between the vanes. As a safety precaution do not pull on the rotor vanes with your fingers.

III. END PLATE DISASSEMBLY - DRIVE END (Part No. 5)

1. Remove air purge hardware from end plate if feeder is equipped with air purge.
2. Remove hex bolts (Part No. 14), which fasten end plate to housing.
3. Pull the drive end plate off the rotor shaft. **Do not attempt to remove the end plate by forcing a wedge between the end plate and the housing.** This could mar the critical machined surfaces of the housing and end plate. Do not hammer on the end of the rotor shaft with a steel hammer, as this will deform the shaft. If force is required, use a gear puller. Be careful not to damage the center in the end of the rotor shaft.
4. Remove bearing (Part No. 16) from the end plate by use of a soft metal or fiber drift. Do not mar or dent any machined surfaces.

IV. END PLATE DISASSEMBLY - THRUST END (Part No. 3)

1. Remove air purge hardware from end plate if feeder is equipped with air purge.
2. Remove bearing lock nut (Part No. 8)
3. Remove hex bolts (Part No. 14), which fasten end plate to housing.
4. Pull the non-drive end plate off the rotor shaft. **Do not attempt to remove the end plate by forcing a wedge between the end plate and housing.** This could mar the critical machined surfaces of the housing and end plate. **Do not hammer on the drive end of the rotor shaft with a steel hammer, as this will deform the shaft.** If force is required, use a gear puller or use a wood block on the drive end of the rotor shaft to hammer on. Note the number of shims on the non-drive end (shims are not used



on type 2 Airlocks) so that the same number can be re-installed at assembly.

5. Remove bearing and seal retainer plate bolts (Part No. 18) and the retainer plate.
6. Remove duplex bearings (Part No. 10) from end plate by use of a soft metal or fiber drift. Do not mar or dent any machined surfaces.

V. END PLATE ASSEMBLY - DRIVE END (Part No. 5)

1. Insert bearing (Part No. 16) in end plate. The bearing should be a light press fit into end plate. Be sure bearing is pressed down against shoulder.
2. For installation of shaft seals (Part No. 13) see Instruction II.
3. Before installing end plate, polish sealing surfaces and bearing journals with a fine (100 grit or finer) emery cloth. Be sure there is no dirt or foreign matter on mating machined surfaces.
4. Install end plate assembly over rotor shaft with rotor in housing.
5. Install hex bolts (Part No. 14), which fasten end plate to housing. Move from bolt to bolt, but not adjacent bolts, and tighten down gradually.

VI. END PLATE ASSEMBLY - THRUST END [non-drive end]

1. Repack the bearings (Part No. 10) in grease as explained in Instruction I.
2. Install bearings in end plate. **PRINTING ON BEARING RACES MUST FACE EACH OTHER.** Bearings should thumb press into housing.
3. If grease retention seals are being replaced, (we recommend replacing these seals any time the bearings are removed) press out old grease seals (Part No. 11) and press in new ones, making sure that lips are facing in the direction shown. Dip new grease seals in oil before pressing into end plate.
4. Re-install bearing and seal retainer plate (Part No. 17) using bolts (Part No. 18). Move from bolt to bolt, but none adjacent bolts, and tighten gradually.
5. For installation of shaft seal (Part No. 13) see Instruction II.
6. Before installing end plate, polish sealing surfaces and bearing journals with a fine (100 grit or finer) emery cloth. Be sure there is no dirt or foreign matter on mating machined surfaces.



7. Laminated shims (Detail No. 12) should now be installed on the rotor shaft (these shims are not required on type 2 Airlocks). These variable thickness shims are selectively installed at the factory at time of original assembly. Their purpose is to axially locate the rotor in the housing with respect to the end plates. The recommended clearance for product temperatures less than 125 DegF is for there to be .004" [.003" go, .005 nogo] clearance on the non-drive end and .008 [.007 go, .009 nogo] clearance on the drive end. For product temperatures 125 DegF and greater the clearance on the non-drive end should be the same as it would be for a low temperature application with all the increase in axially clearance because of temperature expansion being placed at the drive end. The laminated shims removed at time of disassembly should be the correct thickness can be re-installed. New laminated shims are .020 inches thick. Laminations can be peeled off in .002 inch increments.
8. Install end plate assembly over shaft.
9. Install the hex bolts (Part No. 14) which fasten the end plate to the housing. Move from bolt to bolt, but not adjacent bolts, and tighten down gradually.
10. Install bushing (Part No. 9).
11. Install shaft nut lock washer (Part # 7) and then shaft nut (Part # 8). Tighten shaft nut very tightly so that you are sure all end play is taken out between the shoulder of the shaft and the inside races of the bearings. Bend appropriate tab on lock washer into corresponding slot in lock nut so as to prevent the shaft nut from becoming loose when the Airlock feeder is in operation.
12. Check axial clearances (clearances between rotor and end plate) ***if rotor is of the open-end type.*** To increase total axial clearance, a shim or shims (Part No. 19) must be added to the non-drive end. To decrease total axial clearance, shims must be removed from non-drive end. Each shim is .003 thick. The bolts, which attach the non-drive end plate to the cylinder must be removed and the end plate along with the rotor pulled back a couple inches. End plate shims can then be added or removed. It is easier to pull the non-drive end plate and rotor out together rather than removing the non drive end plate from the rotor shaft. This will cause the driven sprocket to be removed or pulled back on the drive end.
13. To axially shift rotor assembly between housing end plates, the thickness of laminated shim (Part No. 12) must be changed. See Instruction VI, 7 for more information.

VII. INSTALLATION OF GEAR REDUCERS

1. When installing or adjusting gear reducer on the motor mounting plate, the bottoms of the four reducer mounting feet must be set equidistant from the face of the motor mounting plate to within +/-1/64th inch. It is



recommended that ***lock joint inside calipers*** be used to check this requirement. Failure to hold the reducer mounting feet in the same plane, parallel to the motor mounting plate may cause enough stress in the reducer to break the feet off during installation or they may break later during operation.

VIII. AIRLOCK FEEDER INSTALLATION

1. An Airlock feeder is a precision piece of equipment operating with small internal clearances. Any distortion in the housing will cause the rotor to rub against the housing and thus cause premature failure of the Airlock. The Airlock should be bolted to a flat surface using a sponge rubber gasket between mating flanges.
2. Before attaching the Airlock feeder to the system, check the interior to which the Airlock is to be bolted to for any foreign materials that might cause the Airlock to bind while in operation.
3. MOST GEAR MOTORS [but not all] are shipped to Magnum Systems with a sufficient quantity of lubricant for operation. BEFORE OPERATION, the user is responsible for checking to see that the gear motor has oil to the proper level. Most gear motors are supplied with three pipe plugs at different levels. The top [breather] plug is where oil is put in the gear head with breather plug removed. The center plug when removed is used to indicate when the proper amount of oil is in the gear head. When oil starts flowing out the center plug [with plug removed], sufficient oil is in the gear head and both the top [breather] plug and the center plug can be replaced. The purpose of the bottom [magnetic] plug is to be able to remove the oil from the gear head and of course should be in place except to drain oil out of the gear head. The customer should check and make sure the breather plug is the highest of the three plugs and the magnetic plug lowest of the three plugs. **NOTE:** Please refer to the operation instructions supplied by the gear motor manufacturer enclosed with your Airlock Feeder or the lubrication instruction plate on the gear motor for more details.
4. Before operating the Airlock, the motor should be “bumped” to determine the proper direction of rotation. When attaching the feeder to the system, take care that the direction of rotation is that which is required.
5. If the Airlock is equipped with air purge hardware, be certain that compressed air is supplied and the solenoid is properly wired before operating the Airlock.

AIR PURGE INLETS ARE PLUGGED WHEN AIRLOCK FEEDER IS NOT SUPPLIED WITH AIR PURGE HARDWARE, DO NOT PUT LUBRICANT IN PLUGGED HOLES.

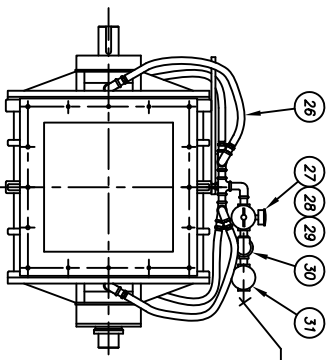

SUPPLY 100 PSI PLANT AIR 1/2 PPT

- NOTES:
1. REFER TO C.F.#10.1-6-B FOR INSTALLATION & MAINTENANCE INSTRUCTIONS.
 2. THIS FEEDER IS A PRECISION PIECE OF EQUIPMENT WITH CLOSE INTERNAL CLEARANCES. DO NOT CAUSE MISALIGNMENT BY BOLTING FEEDER IN A STRAIN.
 3. TO AVOID PREMATURE FAILURE, DO NOT OVER TIGHTEN ON "U" CUP PACKING (DETAIL #13) GLAND PLATE SCREWS (DETAIL #15) SHOULD BE TIGHTENED ONLY ENOUGH TO SQUEEZE "U" CUP PACKING AGAINST PACKING BOX SEAT. WITH CHAIN DRIVE REMOVED, THE ROTOR SHOULD ROTATE BY HAND.
 4. INTERNAL CLEARANCE BETWEEN ROTOR & HOUSING SHOULD BE INCREASED ABOUT .002" WITH STAINLESS STEEL.
 5. INTERNAL CLEARANCES LISTED ARE FOR STANDARD OPERATING TEMPERATURES OR LESS THAN 150 DEG. F.

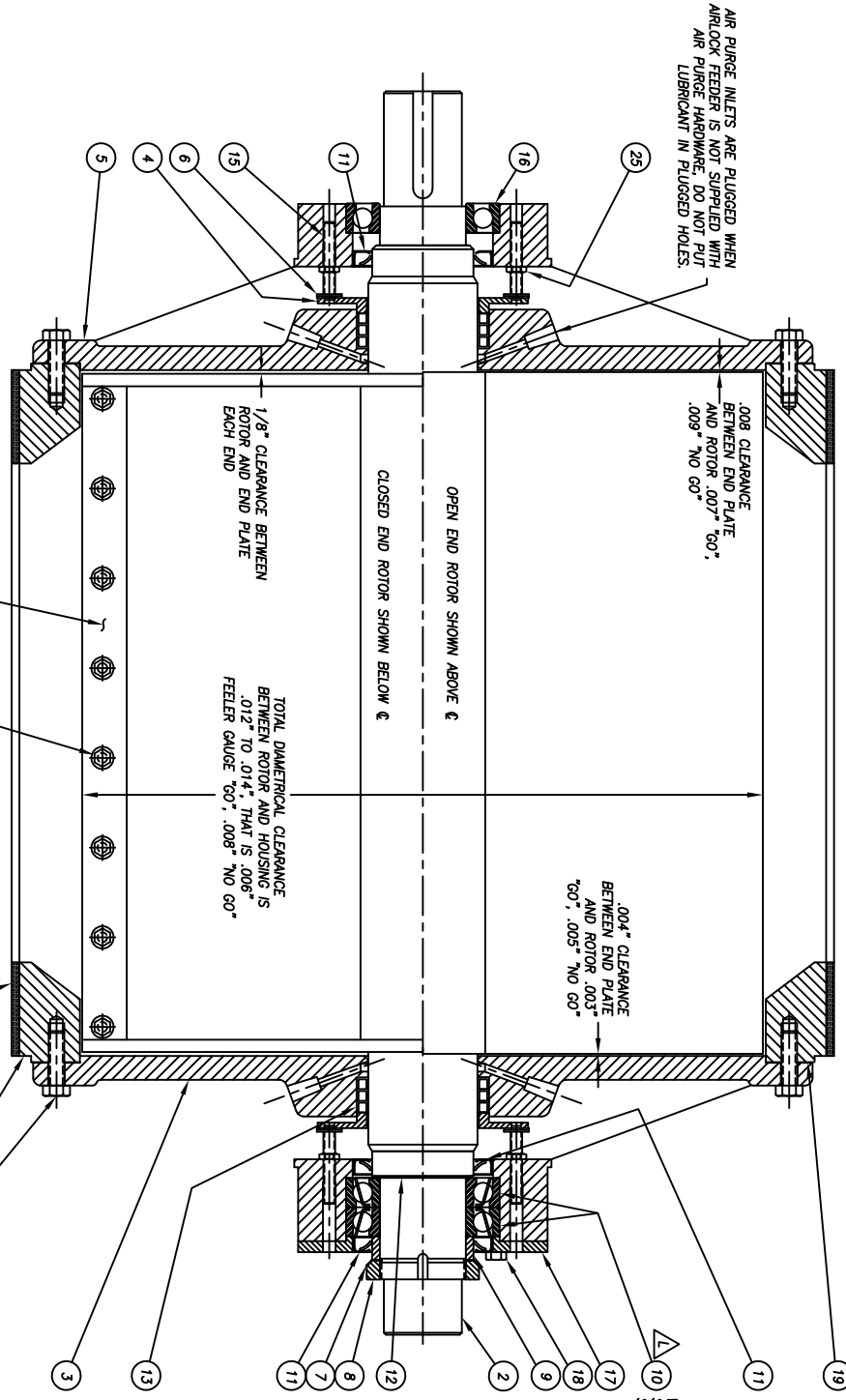

- # RECD. ON OPEN END TYPE FEEDERS ONLY
- * RECD. ON CLOSED END TYPE FEEDERS ONLY
- ▷ SUGGESTED SPARE PARTS
- ONLY REQUIRED WHEN AIRLOCK FEEDER SUPPLIED WITH AIR PURGE ASSEMBLY

WHEN ASSEMBLING BEARINGS, STAMPED BEARING NUMBERS SHOULD FACE EACH OTHER.

WARNING
 DESIGN ENGINEERS, TECHNICIANS & INSTALLERS
 THE INLET AND OUTLET OF THE ROTARY VALVE MUST HAVE PROPER ATTACHMENTS TO PREVENT ANYONE FROM BEING ABLE TO INSERT THEIR HANDS OR ANY OTHER BODY PARTS INTO THE VALVE WHEN IN OPERATION.

REVISED	DATE	BY	NO.	REMARKS
REV'D CLEARANCES	04/07/94	JLG	F	
REV TO ACAD	3/26/91	JLE	D	
BOLT WAS 2" LONG	3/26/91	JLE	C	
ITEM 11 WAS QTY 2	4/25/84	A	B	
REMOVED LOCKNUT	2/14/84	KH	A	
REV'D	11/01/91	WRE	E	
Corrected Part's	2/12/97	BSR	G	
Det12 to Qty 1/AR	12/21/99	DES	H	
Add Note 5	08/08/08	DH	J	
Add Shaft Guard#32	07/28/10	MWH	K	
Corrected #10 DEPICTION	03/22/12	MWH	L	

REV	DATE	BY	NO.	DESCRIPTION
1	5/17/75	DMK	1	
2	5-1-02	DMK	2	

MAGNUM
 SYSTEMS

1500 Shadybrook St. #100
 Dallas, TX 75244
 Phone: 972-242-9900
 Fax: 972-242-9901
 Email: info@magnum-systems.com

2000 Ash Avenue
 Dallas, TX 75247
 Phone: 972-242-9900
 Fax: 972-242-9901
 Email: info@magnum-systems.com

7F22 ROTARY AIRLOCK FEEDER
 OPEN & CLOSED END ROTOR
 CUSTOMER ASSEMBLY

QTY	REV	NO.	DESCRIPTION	COMPONENT PART NO.
1	1	1	F18-22 NON DRIVE SHAFT GUARD	52-181-4
1	1	1	1/2" Flange	A30-020
1	1	1	1/2" 2H N184 Seal Shimrod	V10-080
1	1	1	0-60 PSI Pressure Gauge	A30-050
1	1	1	1/4" x 1/8" Pilot Hex Reducer	F80-440
1	1	1	1/2" Regulator	A30-040
4	4	4	1/2" Push-On Hose	P80-110
4	4	4	3/8-16 Pilot Hx Jam Nut	F12-050
80	80	80	3/8" Pilot Spr Lock Washer	F14-110
160	160	160	5/16 STD Pilot Flat Washer	F14-020
10	10	10	500 Brinell Abrasion Resistant Tip	53-17-7
80	80	80	3/8-16x1.0 Puddingbolt	F10-120
2	2	2	F122 1/4 Ocell Bagg Ringoakt	R10-070
4	4	4	.003" Plastic Shim# 105-7	S11-070
1	1	1	3/8-16x1.25 Puddingbolt	F10-130
1	1	1	F122 Div End Bearer	1059-10-1
4	4	4	3/8-16x2.5 Fulling Socket Socks	B20-080
6	6	6	1/2-1.3x2.0 Phg Hex Bolt	F11-040
1	1	1	F122 .020 Thk/.002 Incr Laminated shim	S11-190
3	3	3	Bearing Seal	P40-120
2	2	2	F122 Non-Dv End Bearer	B20-100
1	1	1	F122 Start Bushing Part	1058-5-1
1	1	1	Bearing Nut	B20-110
1	1	1	Bearing Washer	B20-120
8	8	8	1/4 S&E Pilot Flat Washer	F14-010
1	1	1	F122-1 Drive End Plate Assy	105-9-2
1	1	1	FT1822 Grand Plate Part	105-21-1
1	1	1	F122-1 Nondrv End Plate Assy	105-9-1
1	1	1	F122-2 Rtr Assy (10 Vane Closed End)	1058-7-1
1	1	1	F122-1 Rtr Assy (10 Vane Open End)	1058-4-1
1	1	1	F122-1 Ovl Assy	105-20-1



TROUBLE SHOOTING COMMON ISSUES

PROBLEM	SOLUTION
System Plugs Up	<ol style="list-style-type: none"> 1. Check belt tension on air blower and tighten if loose. 2. Check air filter and clean out. Locate in a place where there is less dust. 3. Check tubing system for any obstructions. 4. Reduce feed-in rate. 5. Air pressure switch setting may be too low. 6. Outlet gate valve too far open.
Excessive Grain Damage	<ol style="list-style-type: none"> 1. May be overfeeding airlock, causing vanes to shear off grain. Reduce feed rate. 2. Air velocity may be excessive. Slow air blower by changing pulleys or by opening gate valve. 3. Damage can occur if system is running at less than full capacity. Increase feed rate. 4. Rubber hose used to change grain direction, or used for extended lengths. 5. Airlock shear protector installed wrong.
Airlock Stops or Noisy	<ol style="list-style-type: none"> 1. A foreign object may have become lodged in the airlock vanes. 2. Check belt tension 3. Check gearbox drive 4. The rotor vanes may be rubbing on the ends of the airlock. Check clearance at both ends of rotor and center in housing by loosening the set screws in the bearings on both ends of the rotor shaft and moving rotor. Tighten set screws after repositioning. 5. The rotor vanes may have become rusted to the airlock housing. The airlock can be broken loose by using a pipe wrench on the exposed rotor shaft. !!CAUTION!! – <i>The worm drive gearbox cannot be driven in reverse and can be damaged. Remove the airlock drive chain before attempting to turn the airlock by hand.</i> 6. “U” cup packings on rotor too tight (Contact Factory)

THE PEOPLE, PARTS, AND SYSTEMS THAT KEEP THE LINE MOVING.

SAFETY FIRST

ROTARY
AIRLOCK

SAFETY

ROTARY AIRLOCK SAFETY PROCEDURES

Prevent damage to yourself and your new Rotary Airlock by following these simple safety procedures.

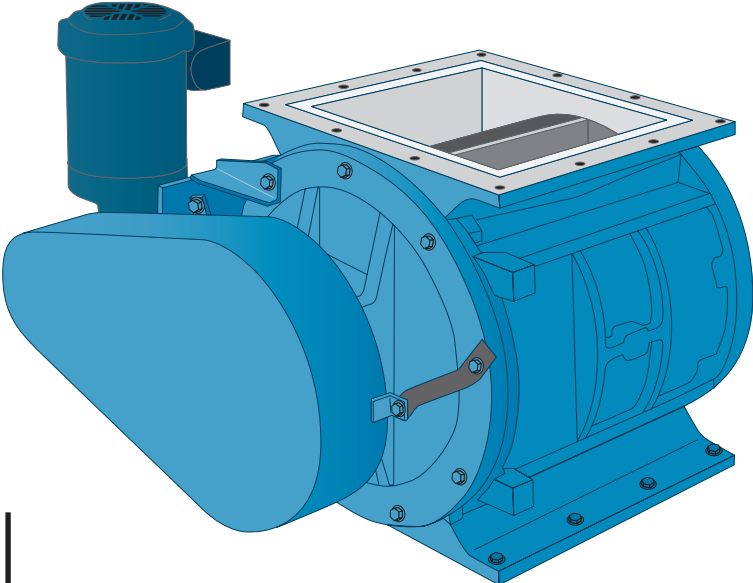



ALWAYS

DISCONNECT power and remove the roller chain BEFORE working on the valve.

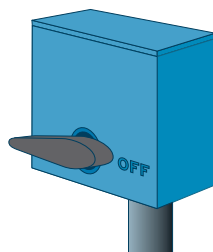

NEVER

Put HANDS into the inlet or outlet openings of the valve.

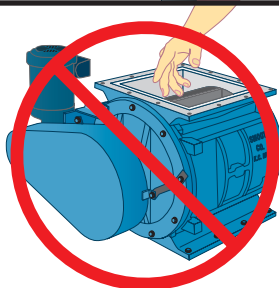

ALWAYS

Have inlet and outlet PROPERLY COVERED when operating valve.

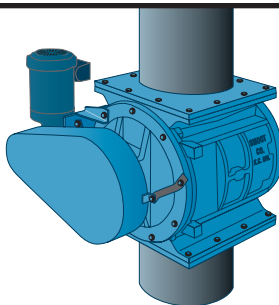

NEVER

Operate the valve WITHOUT chain guard in place.

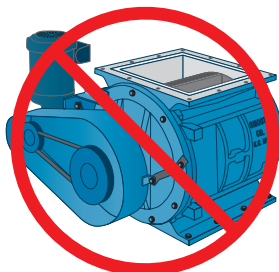

SAFETY FIRST

Rotary Airlocks are powerful and can be dangerous if you do not follow procedures. Prevent damage to yourself and your new Rotary Airlock by following these simple safety procedures.

© Magnum Systems all rights reserved 2019. MS.1058.0519



Toll Free: 888.882.9567
Visit: magnumsystems.com

2205 Jothi Avenue
Parsons, Kansas 67357